

## Table of Contents

<b>Chapter -1 Executive Summary .....</b>	<b>3</b>
a. Introduction .....	3
b. Project background .....	3
c. Need for the project .....	5
d. TBM Tunnelling Technology.....	5
e. Proposed features and configuration .....	5
f. Other aspects.....	5
g. Traffic scenario.....	6
h. Objectives .....	6
i. Project Cost.....	6
j. Construction methodology .....	7
<b>Chapter -2 - Objective and Scope of Work .....</b>	<b>8</b>
2.1 General.....	8
2.2 Project background.....	8
2.3 Existing Connectivity between Western & Eastern Suburbs of Mumbai .....	10
2.4 Need to Strengthen Connectivity .....	11
2.5 Alignments of Proposed Road Tunnel .....	12
2.6 Benefits of the Proposed Project.....	12
2.7 Salient features of the project .....	13
2.8 Objective .....	14
<b>Chapter 3: Socio-Economic Profile of the Project Area .....</b>	<b>15</b>
3.1 Mumbai Sub urban - The Physical Features and the District Profile .....	15
3.2 Thane - The Physical Features and the District Profile .....	20
3.3 Demographic Profile of The Districts .....	24
3.4 The Social Services .....	27
3.5 Economic Features.....	27
3.6 Social and Demographic Profile of the affected Villages.....	29
<b>Chapter 4: Traffic Surveys Forecast and Assignment.....</b>	<b>32</b>
4.1 Introduction .....	32
4.2 Alignment of Proposed Road .....	32
4.3 Methodology.....	34
4.4 Types of Traffic Survey conducted for this report .....	35
4.5 Traffic Survey details.....	43
4.6 Data analysis .....	47
4.7 Traffic projections .....	55
4.8 Conclusion: .....	57
<b>Chapter 5: Engineering Surveys and Investigation .....</b>	<b>58</b>
5.1 General.....	58
5.2 Alternative Alignment studies .....	58
5.3 Recommended Alignment .....	63
<b>Utility Mapping .....</b>	<b>72</b>
Thane Side Utility Mapping.....	72
Borivali Side Utility Mapping.....	72
<b>Geometric Design Standards.....</b>	<b>73</b>
5.4 Salient Features of Alignment.....	75

5.5	Toll Plaza .....	76
5.6	Geotechnical Investigation Report .....	81
5.7	Geology and Seismicity .....	88
5.8	Geotechnical Investigation .....	92
<b>Chapter 6-Detailed Report for TBM Tunnels .....</b>		<b>129</b>
6.0	General Geological Information.....	129
6.1	General layout.....	133
6.2	Assessment of vibration generated by TBM method of tunneling.....	139
6.3	Vibration During Construction .....	140
6.4	Conclusions .....	143
6.5	Bored tunneling .....	144
6.6	Advantages of Tunnel Boring Machine (TBM) .....	145
6.7	Selection of TBM .....	145
6.8	Different types of TBMs .....	147
6.9	Tunnel Excavation – Mucking method selection .....	153
6.10	Tunnel Lining.....	155
6.11	E&M works for the tunnel .....	172
6.12	Tunnel Lighting System.....	199
6.13	Electrical System.....	201
6.14	Tunnel Safety and Risk Assessment.....	209
<b>Chapter 7-Social Impact assessment .....</b>		<b>225</b>
7.1	Social impact assessment (SIA) .....	225
<b>Chapter 8-Environmental Impact assessment.....</b>		<b>234</b>
<b>Chapter 9 -Financial Analysis .....</b>		<b>235</b>
1.1.0	<b>Introduction and Background of the Project.....</b>	<b>255</b>
1.2.0	<b>Financial Analysis for selected option .....</b>	<b>255</b>
2.1.0	<b>Introduction and Background of the Project.....</b>	<b>272</b>
2.2.0	<b>Financial Analysis for selected option .....</b>	<b>272</b>
<b>Chapter 10 -Operation and Maintenance of the project.....</b>		<b>304</b>
10.1	Operations .....	304
10.2	Maintenance .....	304
10.3	Maintenance Manual:.....	305
10.4	O & M activities for tunnels: .....	307
10.5	Monitoring: .....	311
10.6	Minimum Equipment Needed for Tunnel O&M .....	316
10.7	Fund Source of Tunnel O&M Cost .....	316
10.8	CAPACITY DEVELOPMENT FOR TUNNEL O&M.....	317
10.9	Traffic Monitoring and Information Provision .....	319
10.10	Information leaf lets: Case Study (IRC: SP :91 -2019) .....	321
<b>Codes and References .....</b>		<b>322</b>
<b>Chapter 11 -Annexures (Attached separately).....</b>		<b>325</b>
•	Annexure 1 - MSRDC approval note -Option 2 of alignment.....	325
•	Annexure 2- Letter from Forest department for TBM Tunneling method .....	325
•	Annexure 3- Sample calculation for Pre cast Tunnel lining .....	325
•	Annexure 4 -Guideline for design of steel Fiber reinforced precast segments .....	325
•	Annexure 5- Hong Kong TMCLK_CA water fix .....	325
•	Annexure 6 – TMCKL Project information sheet .....	325

## Chapter -1 Executive Summary

### a. Introduction

The MMRDA is engaged in the development of road infrastructure projects in State of Maharashtra and as a part of this endeavor, the MMRDA has decided to undertake “Construction of 11.85 km long of which 10.25 km twin tubes, 2 lanes + An emergency lane each highway tunnel between Thane city and Borivali in Mumbai for connecting Thane Ghodbandar Road to Western Express Highway in the state of Maharashtra”. The proposed tunnel is meant to connect northern suburb of Borivali and Thane. Currently, the 23-km distance between Thane and Borivali via Ghodbandar Road takes almost an hour, and at times, even more if there is traffic congestion.

Thane and Borivali in north Mumbai are separated by a chain of hills, most of which are a part of the Sanjay Gandhi National Park (SGNP). The proposed tunnel will deviate from Ghodbandar Road in Thane and cover 11.85 km beneath the ground through Sanjay Gandhi National Park and Yeoor Hills. It will then connect with Ekta Nagar on Western Express Highway (WEH) in Borivali. The project will be a twin tunnel with two-lanes + an emergency lane on each carriageway (total four-lane).

### b. Project background

Thane Ghodbandar Road (SH-42) is a major link road connecting Mumbai-Ahmadabad Road (NH-8) part of Golden Quadrilateral near Ghodbandar to Mumbai-Agra Road (NH-3) near Kapurbawadi. This link passes through Municipal Limits of Mira Bhayander Municipal Corporation area from Ch.00/000 to Ch.04/400 and thereafter it passes through Thane city urban area from Ch.04/400 to Ch.14/900. This is an important East-West link and carries heavy commercial traffic between NH-3 and NH-8. The Road from Thane to Ghodbandar was constructed and maintained in the past by PWD. The road was handed over to MSRDC on 5th June, 2000 for widening and improvements on BOT basis with concession period up to 31st December 2020. The road widening project was completed in year 2002 with the expenditure of ₹72 Crore and tolling was started from 1st December 2002. Further widening and improvements of ₹100 Crore along with Securitization of toll took place in 2006 with the upfront payment of ₹141 Crore. The Concession Period is for 15 years i.e. up to year 2020.

Presently, Thane is not directly connected to Borivali. The existing alignment connects Thane and Borivali via Thane Ghodbandar Road having length of 23Kms. It is proposed to explore the possibility of another shorter route as a tunnel and economical alignment passing through Sanjay Gandhi National Park including proper and faster layoffs from NH8 (Western Express highway) and Ghodbandar road. An elevated road has also been planned along the Ghodbandar road. The need of connecting the northern suburb of Borivali to Thane through a tunnel passing through Sanjay Gandhi National Park, which is one of the highest visited national parks within city limits in Asia and Yeoor Hills has been foreseen. The two ends of the

proposed tunnel have been separated by a chain of hills, most of which are a part of the national park.

As per the plans, there will be two tunnels of two lanes + an emergency lane each running parallel to each other at a distance of approx. 13 m and connected with each other through cross passages for emergency situations. The alignment will be finalized in such a way that there will be zero disturbances to the ecosystem of the National Park especially the flora and fauna found in the rich biodiversity of the park.

The proposed project will cut down on traffic jams, the pollution, the fuel expenses, and more importantly it will save time of travelling from Eastern to Western Expressway. The total travel time will further reduce by about 60 minutes. The total travel distance will be saved by about 11km and there will be no disturbance to the existing township and nature. This project will lead to fast and smooth movement of traffic from Thane to Borivali and will be environmentally friendly. This project will also reduce congestion on the Ghodbandar Road



1.1 Study Area map

### c. Need for the project

The connectivity between Thane and Borivilli is very important to decongest the road network ahead of the SGNP limits connecting the major highways of Western Expressway and Thane Ghodbandar Road. Average vehicles plying through these 2 roads per day is in tune of 1,00,000 to 1,20,000 PCU with a PHV of around 9000 PCU. The projected volume of traffic in this proposed new connectivity has been estimated to be around 50,000 PCU.

### d. TBM Tunnelling Technology

The major constraint in this connectivity is that a major part of the proposed alignment passes through Sanjay Gandhi National Park which is a Wildlife Sanctuary (WLS) and there are strict restrictions for passing a forest reach through an at-grade / elevated new road connectivity. As per the letter issued by Forest Department only option to cross the SGNP is through a tunnel. Furthermore, since the alignment passes through a wildlife sanctuary, it was evident that the Drill and Blast technology cannot be applied in this case as that will result in vibration on the surface which, in turn, will cause impedance to the normal, free movement of the Wild animals on the ground.

Hence the option of TBM technology is proposed for this project. As per the National and International practices the project cost by TBM technology is about more than 3 to 3.5 times that of normal Drill and Blast technology.

### e. Proposed features and configuration

Total project length	:	11.85 km
Twin Tunnel Length	:	10.25 km
Lane Configuration	:	2 Lanes + 1 Emergency lane in tunnel
Tunnel Diameter (OD)	:	13.05 m

The tunnel alignment will pass through Sanjay Gandhi National Park.

The environmental and forest zone will not be disturbed

The tunnel will be bored by Tunnel Boring Machine.

The expected construction period is 4 years using 4 TBM's

### f. Other aspects

- Fire extinguishers/water hoses, smoke detectors shall be provided at intervals inside the tunnels.
- A project safety plan (PSP) is to be formulated during construction and after construction considering the relevant acts and IS: 4756-1978
- Adequate ventilation system shall be created by mechanical means to ventilate the tunnel.

- Well illuminated retro reflective/led light sign boards shall be installed at entrance and inside the tunnel at appropriate location.

#### g. Traffic scenario

The expected traffic scenario (in AADT nos.) is presented as under:

2-Wheelers	3-Wheelers	4-Wheelers	LCV	Trucks	Bus	Other	Total Volume (both direction), AADT(Veh/Day)
12904	10392	18404	2601	1863	1495	134	47793

#### h. Objectives

- Enhanced safety and level of service for the tunnel users
- Superior operation and maintenance enabling enhanced operational efficiency of the Tunnel Project.
- Minimal adverse impact on the local population and road users due to tunnel construction.
- Minimal adverse impact on environment.
- Minimal additional acquisition of land.

#### i. Project Cost

THANE-BORIVALI TWIN TUNNEL ROAD PROJECT		
Sr. No	Description of Work	Amount in Rs.
1	Preliminary works(Establishment, Mobilisation, Initial Design etc.)	₹ 324,450,000.00
2	Land for casting yard	₹ 19,912,575.90
3	Carrying out Geotechnical survey	₹ 99,606,150.00
4	Tunnelling with TBM(4TBM's)	₹ 112,481,014,725.24
5	Cut & Cover and Shafts (TBM Launch and retrieval)	₹ 4,919,004,641.26
6	Viaduct and Underpass	₹ 1,080,600,893.50
7	Cross Passages	₹ 1,998,649,543.85
8	Molds for segments	₹ 129,780,000.00
9	Lean Concrete	₹ 672,198,570.21
10	<b>System Works</b> (MEP,TVS,FIRE,SCADA,OCC,Toll System,Traffic Management System,Tunnel Lighting,Lifts )	₹ 4,247,790,812.50
11	Provisional Sum(Uilities,R&R ad Misc)	₹ 1,230,000,000.00
	<b>Sub Total (1 to 11)</b>	<b>₹ 127,203,007,912.45</b>
12	Design @ 2%	₹ 2,544,060,158.25
13	Contingency @3%	₹ 3,816,090,237.37
14	Land Acquisition	₹ 7,000,000,000.00
15	GST 18%	₹ 22,896,541,424.24
16	General Consultant Cost @ 2%	₹ 2,544,060,158.25
	<b>Sub Total (12 to 16)</b>	<b>₹ 38,800,751,978.11</b>
	<b>Grand Total</b>	<b>₹ 166,003,759,890.57</b>
	<b>Total Amount in Crores</b>	<b>₹ 16,600.4</b>

## j. Construction methodology

Project will be operated in two packages from both ends on design and build mode

### Package 1-

Construction of Package 1 ( Ch.0+00 to Ch.5+750- Borivali side ) 5.75 km long twin tube, highway tunnel plus Junction arrangement at interchange

The broad scope includes construction of

- Construction of twin tube tunnel with two TBM length 5.1 KM
- Two Lane “Y-Type underpass of 553 + 332 (Total 885 meters underpass)
- Two lane Main carriage way + two lane service road for the residents
- Cut and Cover Tunnels,
- Underpasses, Cross passages,
- An operation control centre building to accommodate the Firefighting systems, tunnel ventilation system and traffic management systems for Borivali side.

### Package 2

Construction of Package -2 (Ch.5+750 to Ch.11.840- Thane side ) 6.09 km long twin tube, highway tunnel plus Junction arrangement at interchange

The broad scope includes construction of

- Construction of twin tube tunnel with two TBM length 5.1 KM
- Two lane road Viaduct of 548 meters,
- Two lane Under passes of 480 meters
- Two lane main carriage way + two lane service road for the residents
- Cut and Cover Tunnels, Cross passages in the tunnel,
- Toll Plaza
- An operation control centre building to accommodate the Firefighting systems, tunnel ventilation system and traffic management systems for Thane side.

## Chapter -2 - Objective and Scope of Work

### 2.1 General

The Mumbai Metropolitan Region Development Authority (MMRDA) is engaged in the development of road infrastructure projects in State of Maharashtra and as a part of this endeavor, the MMRDA has decided to undertake “Construction of 11km long twin tube, 2 lanes each highway tunnel between Thane city and Borivali in Mumbai for connecting Thane Ghodbandar Road to Western Express Highway in the state of Maharashtra”. Initially this project was envisaged by MSRDC. Later as per the government decision the project was handed over to MMRDA. The proposed project is meant to connect the northern suburb of Borivali and Thane. Currently, the 23-km distance between Thane and Borivali via Ghodbandar Road takes almost an hour, and at times, even more if there is traffic congestion.

Thane and Borivali in north Mumbai are separated by a chain of hills, most of which are a part of the Sanjay Gandhi National Park (SGNP). The proposed tunnel will deviate from Ghodbandar Road to Thane and cover 11km beneath the ground through Sanjay Gandhi National Park and Yeoor Hills. It will then connect with Ektanagar on Western Express Highway (WEH) in Borivali. The project will be a twin tunnel with 2 lanes + 1 emergency lane.

AECOM has been entrusted the task of Consultancy Services for preparation of Detailed Project Report for the construction of twin tube, 2 lanes each highway tunnel between Thane city and road to Western Express Highway (Hereafter referred as “Thane – Borivali link”) in the state of Maharashtra vide their letter No MMRDA / Eng / Twin Tunnel / LOA / 2022 / 247-13.05.2022

### 2.2 Project background

Mumbai is the capital of the state of Maharashtra and is considered as the financial capital of India. This Mumbai city is like narrow elongated strip and runs on the north – south axis and the main means of transport network runs north – south directions which are coined as “Eastern express way and Western express way”. In the last decade, the city witnessed numerous changes in terms of infrastructure developments like Mumbai costal road project, Mumbai Trans Harbor link, Santacruz- Chembur link road, Mumbai Metro etc. to name a few. A lot of studies have been undertaken on the Mumbai Road networks and the results from these studies envisaged to establish a link between Eastern express way and Western Express way.

Moreover, Thane Ghodbandar Road (SH-42) is a major link road connecting Mumbai-Ahmadabad Road (NH-8) part of Golden Quadrilateral near Ghodbandar to Mumbai-Agra Road (NH-3) near Kapurbawadi. This link passes through Municipal Limits of Mira Bhayander Municipal Corporation area from Ch.00/000 to Ch.04/400 and thereafter it passes through Thane city urban area from Ch.04/400 to Ch.14/900. This is an important East-West link and

carries heavy commercial traffic between NH-3 and NH-8. The Road from Thane to Ghodbandar was constructed and maintained in the past by PWD. The road was handed over to MSRDC on 5<sup>th</sup> June 2000 for widening and improvements on BOT basis with concession period up to 31st December 2020. The road widening project was completed in year 2002 with the expenditure of ₹72 Crore and tolling was started from 1st December 2002. Further widening and improvements of ₹100 Crore along with Securitization of toll took place in 2006 with the upfront payment of ₹141 Crore. The Concession Period is of 15 years i.e. up to year 2020.

Presently, Thane is not directly connected to Borivali. The existing alignment connects Thane and Borivali via Thane Ghodbandar Road having length of 23Kms. It is proposed to explore the possibility of another shorter route as a tunnel and economical alignment passing through Sanjay Gandhi National Park including proper and faster layoffs from NH8 (Western Express highway) and Ghodbandar road. An elevated road has also been planned along the Ghodbandar road. The need of connecting the northern suburb of Borivali to Thane through a tunnel passing through Sanjay Gandhi National Park, which is one of the highest visited national parks within city limits in Asia and Yeoor Hills has been foreseen. The two ends of the proposed tunnel have been separated by a chain of hills, most of which are a part of the national park.



Figure2.1: - Study area showing existing road link and proposed connection between Thane - Borivali underneath Sanjay Gandhi national park

### 2.3 Existing Connectivity between Western & Eastern Suburbs of Mumbai

Major arterial roads in this region are Western Express Highway leading to NH8 and Eastern Express Highway leading to NH3. Both these Highways; especially Western Express Highway (5+5 lane wide) experiences huge traffic jams between 8am to 12pm in the morning and 6 pm to 11 pm in the evening with average travel speed reduced to less than 20 km/hr, resulting in huge fuel loss, causing major air and noise pollution in the city.

At present the main east-west connecting links between these two major arterial roads from Bandra to Dahisar on Western Express Highway and Sion to Mulund on Eastern Express Highway, as shown in are as below.

1. Bandra – Sion Road
2. SCLR (Santacruz - Chembur Link Road)
3. AGLR (Andheri-Ghatkopar (Kurla) Link Road)
4. JVLR (Jogeshwari – Vikroli Link Road)

All these links are overcrowded and experience huge traffic jams. Further, there is no east-west link available between JVLR and Thane-Ghodbandar Road i.e. between Jogeshwari to Mira Bhyander on Western Express Highway – NH8 and Vikroli to Thane on Eastern Express highway-NH3. The next link available is Thane-Ghodbandar Road connecting Thane on NH3 and Ghodbandar on NH8. Due to non-availability of east-west connectivity, vehicles coming from NH8 (Ahmedabad) and Western Suburbs, (Goregaon to Mira Bhyander) and going to Thane or to eastern suburbs must travel upto Ghodbandar, take Thane-Ghodbandar Link and then to their destination in eastern suburbs. Similarly, vehicles from Nashik, Kalyan-Dombivali, Navi Mumbai, Thane, and Eastern Suburbs going to western suburbs must take Thane-Ghodbandar link and from Ghodbandar they travel to their destination. Thus, large numbers of vehicles must take huge detours leading to wastage of time and fuel and resulting in more air and noise pollution. Considering the present east-west traffic volume and future increase; at least two to three new connectivity links between JVLR and Thane Ghodbandar Road needs to be developed.

#### 2.4 Need to Strengthen Connectivity

The current population of MMR region is about 18.5 million (2011 census) and out of this population about 70% of the population resides in Mumbai Suburb (east-west) and Thane region. Major developments are also happening in this region. The need for connectivity between two suburbs has been studied with respect to projected increase in population, traffic volumes and response from existing transportation networks as summarized below.

A study conducted by Mumbai Metropolitan Region Development Authority (MMRDA) titled “Comprehensive Transportation Study for Mumbai Metropolitan Region” has analyzed three preferred deferent development scenarios. Some of the results of analysis providing projection of increase in traffic are presented below.

After reviewing the growth of population, employment, and external goods vehicle travel by 2031 as compared to 2005 (1.63 times growth in population, 2.04 times growth in employment and 4.00 times growth in external goods travel), a growth factor of 3.00 has been assumed for internal goods vehicle travel by 2031. External travel demand, vehicle entering, leaving, or passing through the MMR play a crucial role, connecting the study area with the state and the rest of India principally along the national and state highway, Eastern Express highway, Sion-Panvel Highway, Thane-Ghodbandar Road, etc.) corridors connecting the ports (Wadala Truck Terminal Road, Rafi Ahmed Kidwai Road, PD’Mello Road, NH4B, SH54, etc.) economic growth in the catchment areas of the connective road systems.

Over a period of 17years (2005-22), it is observed that the private vehicle (two-wheeler and car) model share has increased from 12.8% to around 21.5%. IPT trips (Auto Rickshaw and Taxi) area have decreased from 9.1% to around 5.6 % in three different growth scenarios reflecting the increase in private vehicle ownership and walk to metro.

Therefore, considering the potential increase in demand and limited available connectivity, strengthening of existing roads have been proposed by removing bottlenecks and additional connectivity is proposed.

## 2.5 Alignments of Proposed Road Tunnel

The Proposal has been transferred from MSRDC to MMRDA in the year 2020 where The alternative routes were analyzed, on this alignment the geotechnical investigations and geophysical studies were taken up after getting the approval of the forest department. The tentative options as identified during the preliminary assessment. Three portals on either end were identified and respective alignments were evaluated. Many possible alignments due to involvement of forest and defense land to a large extent were rejected. Other possible alignments (Option-1, Option-2 and Option-3) are discussed subsequently. One alignment was finalized for further studies in consultation with MMRDA.



## 2.6 Benefits of the Proposed Project

In view of the increasing traffic load on thane Ghodbandar road, it is necessary to look for an alternative. Therefore, road tunnel passing below Sanjay Gandhi National Park is being proposed which will provide fast and smooth movement of traffic from Thane to Borivali. The distance between thane and Borivali is also expected to reduce by over 15 kms. This will also result in smooth traffic flow and saving fossil fuel and protecting environment due to reduced vehicular emissions.

- Distance saving for Thane to Borivali by about 15 Km.
- No disruption to existing township
- Travel time saving 20 to 25 minutes

Road tunnels were adopted in past only where other practicable means of road were not possible mostly for the highways in hilly terrains. Urban road tunnels were often discouraged due to an expensive option. However, it is increasingly difficult to provide the additional road space that may be required. Tunnels reduce noise, air pollution, community disharmony and are visually attractive unlike surface roads. The intangible costs, such as effect on community health, air pollution and noise, make tunneling viable if they are assessed. Construction costs are used to compare alternative transportation routes and in case other factors are considered, then tunneling would become a viable option. Currently the local community has to bear these costs as they are not recognized or accounted for in the normal evaluation of alternatives.

## 2.7 Salient features of the project

The salient features of the project provided by MMRDA, the Authority, are given below:

- Construction of new 2-lane + 1 emergency Lane (2+1) in both Tunnels , 11.8 km long twin tunnel starts at Thane side and ends on NH-8 at Borivali.
- The length of bored tunnels will be 10.25 km
- Tunnels will be inter-connected by cross passages at a distance of 300 meters
- Vertical Clearance in the tunnel will be 5.50 m and diameter of 13.05 m. (external)
- A minimum distance between Two twin tunnels will be greater than 13.05m (1d) apart in base. Each tunnel will consist of unidirectional two lanes+ an emergency lane.
- Gradient proposed in Tunnel is  $\pm 2.5\%$  (1 in 40) in 500m stretch.
- The tunnel alignment will pass through Sanjay Gandhi National Park.
- The environmental and forest zone will not be disturbed
- The tunnel will be bored by Tunnel Boring Machine.
- The expected construction period is 5 years
- Fire extinguishers/water hoses, smoke detectors shall be provided at intervals inside the tunnels as per NFPA502 and BD 78/99
- A project safety plan (PSP) is to be formulated during construction and after construction considering the relevant acts and IS: 4756-1978
- Adequate ventilation system shall be created by natural or mechanical means to ventilate the tunnel. as per provisions of NFPA502 and BD 78/99
- Well illuminated retro reflective/led light sign boards shall be installed at entrance and inside the tunnel at appropriate location as per provisions of CIE 88 2004

## 2.8 Objective

The objective of this Consultancy is to undertake feasibility studies and prepare a Feasibility Report and Detailed Project Report (DPR) of the Project Tunnel for the purpose of firming up the Authority's requirements in respect of development and construction of the Project Tunnel and Project Facilities and enabling the prospective bidders to assess the Authority's requirements in a clear and predictable manner with a view to ensuring:

- a) enhanced safety and level of service for the tunnel users
- b) superior operation and maintenance enabling enhanced operational efficiency of the Tunnel Project.
- c) minimal adverse impact on the local population and road users due to tunnel construction.
- d) minimal adverse impact on environment.
- e) minimal additional acquisition of land; and
- f) phased development of the Project Tunnel for improving its financial traffic that may be caused if additional works are undertaken within a period of seven years from the commencement of construction of the Project Tunnel.

Furthermore, the objectives also include:

- i. Establishing the technical, environmental, social, economic, and financial viability of the project accounting the tunnel design and construction based on general topography of the area with provisions of approach roads, intersections, tunnel safety feature, quantity of various items of work and cost estimates and economic analysis
- ii. Inclusion of tunnel and highway design for tender purposes, pavement and overlay with options for flexible or rigid pavements, design of cross drainage structures and grade separated structures, design of service roads, BOQ, working drawings details, detailed cost estimates, economic and financial viability analyses, environmental and social impact assessment, and actions as appropriate and tendering documents on commercial basis for international or local competitive bidding.
- iii. Finalizing the best method of execution of the project through BOOT/DBFOT/ Annuity / Hybrid model /EPC mode.

## Chapter 3: Socio-Economic Profile of the Project Area

### Introduction

The project influence areas of the proposed project are located in the districts of Mumbai Suburban and Thane in the state of Maharashtra. The proposed project is to construct Twin tube, 2 Lanes + 1 emergency lane (each side) highway tunnel of about 10.2 km, which passes through below the Sanjay Gandhi National Park (SGNP), connecting Western Express Highway (WEH) near Borivali and Ghodbandar road (of Thane). This link passes through Municipal Limits of Mira Bhayander Municipal Corporation area from Ch.00/000 to Ch.04/400 and thereafter it passes through Thane city urban area from Ch.04/400 to Ch.14/900. This is an important East-West link and carries heavy commercial traffic between NH-3 and NH-8. In order to appreciate the socio-economic profile of the influence area of the project, a micro-level analysis has been done.

The description of socio-economic features of the districts through which the project road traverses comprise the demographic, social and economic aspect of the population, it includes the features of population distribution, density of population, workforce and share of workers in major economic categories, and the vulnerable groups.

The physical and socio-economic profile of all the districts concerned is illustrated separately in the following sections.

### 3.1 Mumbai Sub urban - The Physical Features and the District Profile Area and Location

Mumbai Suburban District is a district of Maharashtra in Konkan Division. Its headquarters is in Bandra. It consists of three administrative subdivisions: Kurla, Andheri, and Borivali. The district along with Mumbai City district and other suburban communities make up the metropolis of Mumbai on Salsette Island. The district occupies an area of 446 km<sup>2</sup>.

This is the second smallest district of Maharashtra, and it administratively comes under Konkan Division. Mumbai Suburban district was created on 1 October 1990 when Greater Mumbai bifurcated into Mumbai City and Mumbai Suburban district. Mumbai Suburban District has 3 Talukas/Tahsils namely, Andheri, Borivali and Kurla. It has 87 villages. The jurisdiction of Mumbai Suburban District is from Bandra to Dahisar, from Kurla

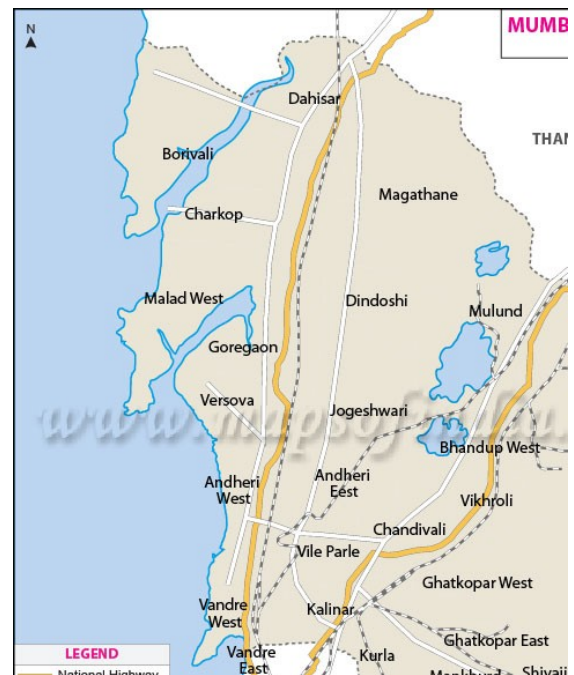

(Chuna Bhatti) to Mulund and from Kurla and upto Trombay Creek.

Geographically Mumbai Suburban is divided four regions i.e. East – Thane Creek from Mulund to Trombay, Vikroli, Ghatkoper, West – Arabian sea from Gorai Manori to Andheri & Bandra having beaches of Madh, Juhu, South – Mahul, Mahim Creek of Mumbai City District and North – National Park and Thane Creek.

### **Climate and Rainfall**

Mumbai has a tropical climate, specifically a tropical wet and dry climate (Aw) under the Koppen climate classification, with seven months of dryness and peak of rains in July. The cooler season from December to February is followed by the summer season from March to June. The period from June to about the end of September constitutes the south-west monsoon season, and October and November form the post-monsoon season. The climate of Mumbai Suburban district average is 27.2 °C and average precipitation is 242.2 cm (95.35 inches). The mean maximum average temperatures is about 32 °C (90 °F) in summer and 30 °C (86 °F) in winter, while the average minimums are 25 °C (77 °F) in summer and 18 °C (64 °F) in winter. Mumbai experiences three distinct seasons: 1. Winter (Nov to Feb or mid March) winter temperature 15 to 20 degree C Peak Winter Months - Dec to Mid Feb with temperature range 12-19 Deg C; 2. Summer (Feb/March to mid-June and Sept to Nov) Avg temperature 30 to 27 Deg. C; Peak Summer Months (Mid-March to June 1 week), temperature shoots up to 30 - 40 Deg. C with humidity being approx 70-80%. 3. Monsoon: (June to August, at times until October). Peak monsoon months: July & August sometimes with winds and thunderstorms. Temperatures at 24-29 Deg C.

The average annual rainfall in the district is about 2,373.4mm. During the period from June to September is about 2260.4mm, October to December is about 100.8mm. Some rainfall occurs during the pre-monsoon months.

### **Agriculture**

Agriculture is the main source of livelihood in Maharashtra, but Mumbai Suburban district has no agriculture/irrigated land. Water is the essential factor in agriculture sector. It has played an important role in developing agriculture sector through increasing cropping intensity and per hectare yield and minimised uncertainty of unpredictable rainfall. Consequently, per capita income and standard of living of rural people has increased rapidly in highly irrigated areas of Maharashtra.

### **Industries**

Mumbai is the commercial and entertainment capital of India, it is also one of the world's top 10 centres of commerce in terms of global financial flow, generating 5% of India's GDP, and accounting for 25% of industrial output, 70% of maritime trade in India (Mumbai Port Trust & JNPT), and 70% of capital transactions to India's economy.

As far as industries are concerned in Mumbai Suburban district, most of them are based on Woollen, silk & artificial tread-based clothes, Rubber, Plastic & Petro based Electrical

machinery and transport equipment etc. There are 635 large scale units and 6589 micro, small and medium scale units.

### **Forest**

An area of 53 sq. km is covered under dense forest and 29 sq.km is covered under open forest. Out of that 15sq.km dense mangrove and 11 sq. km open mangrove forest. Which is 11.3% of the total area of the Mumbai Suburban district.

### **Infrastructure in Mumbai Suburban District**

- **Education**

Schools in Mumbai are either "municipal schools" (run by the MCGM) or private schools (run by trusts or individuals), which in some cases receive financial aid from the government.[365] The schools are affiliated with either of the following boards: (i) Maharashtra State Board (MSBSHSE), (ii) The All-India Council for the Indian School Certificate Examinations (CISCE), (iii) The National Institute of Open Schooling (NIOS), (iv) The Central Board for Secondary Education (CBSE), (v) The International Baccalaureate (IB), (vi) The International General Certificate of Secondary Education (IGCSE).[366] Marathi or English is the usual language of instruction. The primary education system of the MCGM is the largest urban primary education system in Asia.

Under the 10+2+3/4 plan, students complete ten years of schooling and then enrol for two years in junior college, where they select one of three streams: arts, commerce, or science. This is followed by either a general degree course in a chosen field of study, or a professional degree course, such as law, engineering and medicine. Most colleges in the city are affiliated with the University of Mumbai, one of the largest universities in the world in terms of the number of graduates. There are 2108 primary school, 909 middle schools and 1308 secondary and senior secondary schools.

- **Health Services**

Mumbai has a vast supply of public and private health care services. The services range from the super speciality, tertiary-level care hospitals to the general practitioners The Central Government has its own dispensaries, which are available only for their employees. Further, there are the Employees' State Insurance Scheme (ESIS) health care services that include hospitals and dispensaries which cater to employees in the organised sector. The various government organisations, such as ports, railways and defence, have their own health care services for their employees. For the general population, the Municipal Corporation of Greater Mumbai (MCGM) provides major facilities in the public sector along with the State Government.

Mumbai Suburban District has 747 Allopathic, 170 Ayurvedic, 7 Unani and 763 Dispensaries.

- **Airways**

The Chhatrapati Shivaji International Airport (formerly Sahar International Airport) is the main aviation hub in the city and the second busiest airport in India in terms of passenger

traffic. It handled 36.6 million passengers and 694, 300 tonnes of cargo during FY 2014–2015. An upgrade plan was initiated in 2006, targeted at increasing the capacity of the airport to handle up to 40 million passengers annually and the new terminal T2 was opened in February 2014.

The proposed Navi Mumbai International Airport to be built in the Kopra-Panvel area has been sanctioned by the Indian Government and will help relieve the increasing traffic burden on the existing airport. The Juhu Aerodrome was India's first airport, and now hosts the Bombay Flying Club and a heliport operated by state-owned Pawan Hans.

- **Railways**

The Mumbai Suburban Railway, popularly referred to as Locals forms the backbone of the city's transport system. It is operated by the Central Railway and Western Railway zones of the Indian Railways. Mumbai's suburban rail systems carried a total of 6.3 million passengers every day in 2007. Trains are overcrowded during peak hours, with nine-car trains of rated capacity 1,700 passengers, actually carrying around 4,500 passengers at peak hours. The Mumbai rail network is spread at an expanse of 319 route kilometres. 191 rakes (train-sets) of 9 car and 12 car composition are utilised to run a total of 2,226 train services in the city.

The Mumbai Monorail and Mumbai Metro have been built and are being extended in phases to relieve overcrowding on the existing network. The Monorail opened in early February 2014. The first line of the Mumbai Metro opened in early June 2014.

- **Road System**

Mumbai is served by National Highway 3, National Highway 4, National Highway 8, National Highway 17 and National Highway 222 of India's National Highways system. The Mumbai-Pune Expressway was the first expressway built in India. The Eastern Freeway was opened in 2013. The Mumbai Nashik Expressway, Mumbai-Vadodara Expressway, are under construction. The Bandra-Worli Sea Link bridge, along with Mahim Causeway, links the island city to the western suburbs. The three major road arteries of the city are the Eastern Express Highway from Sion to Thane, the Sion Panvel Expressway from Sion to Panvel and the Western Express Highway from Bandra to Dahisar. Mumbai has approximately 1,900 km (1,181 mi) of roads. There are five tolled entry points to the city by road.

- **Sea**

Mumbai is served by two major ports, Mumbai Port Trust and Jawaharlal Nehru Port Trust, which lies just across the creek in Navi Mumbai. Mumbai Port has one of the best natural harbours in the world, and has extensive wet and dry dock accommodation facilities. Jawaharlal Nehru Port, commissioned on 26 May 1989, is the busiest and most modern major port in India. It handles 55–60% of the country's total containerised cargo. Ferries from Ferry Wharf in Mazagaon allow access to islands near the city. The city is also the headquarters of the Western Naval Command, and also an important base for the Indian Navy.

### Places of Interest

- *Sanjay Gandhi National Park:* Popularly known as “Krishnagiri Upvan” or “Borivali National Park”, National park is spread over a very vast area of about 104 sq. Km. It is at a distance of 1 km from the Borivali Railway station on Western Railway. The Western Express Highway is quite near from the main gate of the park.
- *Chhota Kashmir:* It is a colourful garden developed in the Aarey colony area just near the Aarey Diary. The garden is full of variety of colourful flowers, which blossom in all seasons round the the year. The ever green lawns of the garden , the tall coconut trees and the beautiful palm trees grown here simply remind us of natural beauty of Kashmir. This may perhaps be the reason of calling this garden as ‘Chhota Kashmir’.
- *Mumbai Film City:* Indian film industry is one of the largest film industry in the world, and the film industry accounts for 60% of the films produced in India. The Kalgarre complex has been established at Goregaon in India. Mumbai has played a pivotal role in the development of cinematography. The first feature film Raja Harishchandra was produced in the city by Dadasaheb Phalke , the father of Indian cinema. Since then the Mumbai has remained the main center of indian Film Industry for a period of century. The film city has been named as Dadasaheb Phalke Chitranagari for the memory of the father of Indian film industry Mr. Dada Saheb Phalke .
- *Kanheri Caves:* The caves pave through the Sanjay Gandhi National Park, situated in the hills on the vast land of this udyan, the caves are an excellent work of architecture. According to the historians the caves were carved between 200 D.C. and 600 A.D. Few sculptures excavated in these caves are amazing. The caves comprises of about 109 Buddha Viharas, specially designed for the Bhikshus. It indicates that the kanheri was a large monastic settlement, probably established in the 1<sup>st</sup> century A.D. The cells here are provided with stone beds, cisterns for storing water and walkways. The caves are famous in the country for beautiful architect displayed in its interior and exterior parts.
- *Juhu Beach:* It is the most popular beach in Mumbai. Spread over five Kms long seashore along along coastal line. The beach is frequently visited by tourists. The beach is generally crowded in the evening as the visitors usually come these hours for fresh air and pleasure strolling.
- *Mahakali Caves:* These caves have been carved in a small hill at a distance of 6 kms from the andheri railway station on the western railway. The sanctuary must have been a major religious centre during the Buddha period. The cave comprises of 19 viharas.
- *Powai Lake:* Powai Lake is an artificial lake, situated in Mumbai Suburban district, in the Powai valley, where a Powai village with a cluster of huts existed. The city suburb called Powai shares its name with the lake. Indian Institute of Technology Bombay, one of the premier institutions of science and technology in India, is located to the east of the lake.

### 3.2 Thane - The Physical Features and the District Profile Area and Location

The district is situated between 18°42' and 20°20' north latitudes and 72°45' and 73°48' east longitudes. The revised area of the district is 4,214 km<sup>2</sup>. Thane district is surrounded by Pune and Ahmednagar districts to the east, The Arabian Sea to the west, Palghar district to the north, Mumbai City District and Mumbai Suburban District to the



southwest and Raigad District to the south. The district is in the northernmost part of the Konkan lowlands of Maharashtra. It comprises the wide amphitheatre like Ulhas basin on the south and hilly Vaitarna valley on the north together with plateaus and the slopes of Sahyadri in the east, the land falls through a succession of plateaus in the north and centre of the district to the Ulhas valley in the south. These lowlands are separated from the coast by a fairly well-defined narrow ridge of hills that runs north-south to the east of the Thane creek.

The state of Maharashtra has 36 districts in all and Thane is one of them. The district is on the western coast and comes under the Konkan division of the state. The district was originally divided into 15 talukas, viz. Thane, Kalyan, Murbad, Bhiwandi, Shahapur, Vasai, Ulhasnagar, Ambarnath, Dahanu, Palghar, Talasari, Jawhar, Mokhada, Vada and Vikramgad. However, on 1<sup>st</sup> August 2014, the district was divided in two districts; Palghar and Thane district. Palghar district include 8 of these talukas, Now Thane district comprises of seven talukas viz Thane, Kalyan, Murbad, Bhiwandi, Shahapur, Ulhasnagar and Ambarnath. There are 430 Gram panchayats, 807 villages with habitation and 13 villages with no habitation.

#### Climate and Rainfall

The climate of the district is distinctly different on the coastal plains and on the eastern slopes. Being fully tropical, the climate on the coast, the coastal strip including Thane, Vasai, Palghar and Dahanu tahsils is very humid and warm. On the other hand, the climate on the eastern slopes and in the plains at the foot of the slopes is comparatively less humid. The maximum temperature varies from 28.0 to 35.2 centigrade and the minimum temperature varies from 16.3 to 26.5 centigrade. The climate of the district is suitable for horticulture and plantation crops.

The district receives average rainfall of 2000 to 4000 mm from the South-West monsoons during the months June to September. Generally, highest rainfall is recorded in the month of July. The rainfall is more inland as compared to the coastal areas. The southern areas of Thane district receive more rainfall than the northern areas of the district.

## Agriculture

Agriculture is one of the predominant activities in Maharashtra including major villages in Thane district. The important kharif crops of the district are rice, nagali vari and nachani. Urad, moong and kulith are some of the pulses that are also grown in this season. Soyabean, groundnut, sunflower & wal are also grown by the farmers Paddy is the major food crop for the district. Rice is grown in all the talukas of the district but mainly in Palghar, Bhiwandi, Murbad, Shahapur, Vada, Vikramgad and Dahanu. The hilly areas of the eastern part of the district, namely Jawhar, Murbad, Vikramgad, Shahapur and Mokhada talukas have rich fields of Vari and Nachani. Wal, chavali and gram are the main rabi crops grown in this district. The climate of the district is also suitable for horticulture and plantation crops. A variety of vegetables, flowers & fruit crops are grown in the district as horticultural crops. Among the vegetables, eggplants are grown on a large scale. Dahanu taluka is famous for fruits. Chikoos (sapotas) are grown on a large scale at Gholwad. Chikoo orchards are also found in Palghar and Talasari talukas. Chikoos grown in these areas are sold all over India. Guavas, mangoes, papayas, grapefruits and coconuts are the other major fruits grown in these areas. Different varieties of bananas such as rajeli, tambeli, mutheli and velchi are grown in Vasai and Palghar talukas. Bor, wild berries and litchis are some of the seasonal fruits grown in this district have great demand in the markets of Mumbai. Dahanu is also famous for its rose gardens. The land utilization as per 2011-12 of Thane district, out of the 956'000 ha. The net sown area in the district was 356'000 ha.

## Industries

Thane is the third most industrialized district in the State. The Thane-Belapur-Kalyan industrial belt is the Centre of highly sophisticated modern industries. The industrial growth in the district, however, is concentrated in this industrial belt. The district can be divided into three district parts. The first is the area under direct influence of Mumbai metropolis. This area is more or less suburban to the metropolis and includes Thane, Kalyan and Ulhasnagar talukas where a number of organized modern industries are concentrated. The second zone comprises the industrially developing areas of Bhiwandi tehsils of Thane District. The third part includes the rest of the area of the district having conventional village industries, age-old cottage industries and primary processing agro-industries.

There are 442 registered Large Unit and 16962 Micro, Small & Medium scale industries operating in district such as Cotton textile, Woolen, silk & artificial tread-based Clothes, Chemical/Chemical based, Rubber, Plastic & petro based, Engineering units etc. Major Exportable item Nylon Synthetic Readymade Garments, Embroidered Fabrics, Textiles, Cotton & Art, Silk, Food Products, Pharmaceutical Product, Engineering products, Chemicals.

## Forest

The total area under forest in the Thane and Palghar district is 3842 Sq. Kms which was one of the highest in the State. Out of this total forest area, most of the forest area is spread in Shahapur and Murbad tehsils of Thane District and Palghar District excluding Vasai Tehsil.

The main forest products of the district are Sag, Ain, Hirda, Timber wood which are used for construction purpose.

### **Minerals**

There is no major mineral or mining in the district. However, the mining activities in the district are confined to quarrying of stones and sand which is carried on especially at places which are near urban areas in Kalyan, Bhiwandi and Thane Tehsils. The clay is used for making bricks, tiles and cheap red glazed wares.

### **Infrastructure in Thane District**

#### **• Education**

Thane district is well equipped with good number of schools and colleges however; most of the popular institutes are in Mumbai. However, Thane district enjoys locational advantage as it is close to Mumbai.

There are 149 colleges, 20 Govt. ITI colleges, 14 Pvt. ITI colleges, 15 Technical Degree Colleges, 20 Technical Diploma Colleges, 5756 primary school and 1807 Secondary & senior secondary school.

#### **• Health Services**

Thane district is well equipped with hospitals for the treatment of almost all kinds of diseases. However the major hospitals are located in Mumbai district. There are various private insurance Companies besides Life Insurance Corporation providing insurance services in Thane district.

The district has 186 Primary Health Centre (PHC), 565 Primary Health Sub-Centre (PHSC), 48 Hospital and 66 Dispensaries which have the facilities and experiences to provide the best health services.

#### **• Airways**

Thane does not have an airport of its own. Chhatrapati Shivaji Airport in Mumbai is 16 KM away from Thane. The airport is well connected to all major cities in India.

#### **• Railways**

Thane can be easily reached from any part of the country via rail. There are regular trains from Thane to all the major cities across India and it is considered to be the most convenient mode of transport here. It has been ranked as the busiest station on the Mumbai suburban network.

The total railway track length in the district is 345.73 km. spread in western and central part of the district. The Western Railway network passes through Vasai, Palghar and Dahanu

talukas of the district and Central railway network passes through Thane, Kalyan, Ulhasnagar and Shahapur talukas of the district. Western Railway local trains ply from Churchgate up to Dahanu. Central Railway local trains leaving from Chhatrapati Shivaji Terminus go up to Kalyan, Ambarnath, Badlapur, Karjat and Kasara.

#### • Road system

Thane is well connected to other major cities of the country via regular buses. Public-sector transport is provided by Maharashtra State Road Transport Corporation (MSRTC). Thane has one central bus station which is well-linked to all cities across India. There are also various private agencies in the city, that offer numerous bus services to places.

#### Places of Interest

Thane is known as the Lake City and lies in the state of Maharashtra. It covers an approximate area of about 150 sq km and has a population in excess of 2.4 million. Also known as Shri Sthanak, Thane is located in the northeastern part of Mumbai. Situated on the Salsette Island, Thane has an elevation of seven metres above sea level and is surrounded by hills on all sides – mainly the Parsik Hill and the Yeoor Hill.

- *Malshej Ghat*: Malshej Ghat is on Kalyan Nagar road. Though it is popular as a rainy tourist yet, it is soon evolving as a place of perennial cooling, like Mahabaleshwar and Matheran. The hill surrounded by a dense shawl in the rainy season makes the tourists go mad. Now there are special points being created for tourists visiting Ghat. There are two special parking arrangements on the road for business vehicles. M.T.D.C. and forest department has undertaken development works in the Ghat area and hence the facilities are being provided to tourists.
- *Haji Malang Gad*: Haji Malanggad is fort near about 15 km from Kalyan in Thane district. It is the religious place known as Sri Malang or Haji Malang. Shilahr Raja built the fort of Malanggad. The ancient temple of Machhindranath is on this fort. Haji Malang is the grave of a Muslim monk. Puja of Muslim monk is done by Hindu people. Yatra is on Magh Poornima.
- *Yeoor Hills*: Yeoor Hills, known also as Mama Bhanja Hills is a popular holiday retreat in Thane. Yeoor Hills of Thane is the northern reaches of Sanjay Gandhi National Park and is a home to 12 species of animals and 78 species of birds. Yeoor Hills is a pollution free hill station which is also famous for its 150-year-old holy shrine of Mama Bhanja. These hills also house Swami's Math which is very popular.
- *Kelva Beach*: Kelva Beach is one of the main attractions located in the vicinity of Thane. Kelva Beach is one of the largest beaches in Maharashtra as it is stretched along 7 km of the coastline of Arabian Sea. Kelva Beach, spotted with Suru trees, is a popular weekend destination in Maharashtra. The beach also has Kelva Fort and Sheeladevi temple to its visitors

- *Upvan Lake*: Upvan Lake is one of the main attractions of Thane. Upvan Lake, situated towards the Pokhran-II area bounded by the Yeoor Hills, is considered among the biggest lake in Thane.
- *Thane Creek*: Thane Creek is a prominent bird conservation site in India which is managed by the Indian Bird Conservation Department. Thane Creek is home to over 205 species of birds which include rare species like whistling teals, golden plover, grey plover, hoopoe and avocet as well as common water fowls such as lesser flamingo, greater flamingo, Asian open bill stork, white stork, pied avocet, eastern golden plover, ruddy turnstone and dunlin.
- *Naneghat Hills*: Naneghat Hills is one of the main tourist attractions located in the Malshej region of Thane. Naneghat Hills, which has an altitude of 838.2 m above the sea level, is known for its ancient mountain pass from Ghatmatha to Konkan. This mountain pass also consists of several caves and rock-cut water cisterns.

### 3.3 Demographic Profile of The Districts Population

The project road falls in the district of Mumbai Suburban and Thane in Maharashtra state and it is expected that about 18.17% of the State are likely to be directly or indirectly benefited by the project (Table 3.1).

**Table 3.1: Affected Population**

State/ Districts	Population		
	Male	Female	Total
<b>Maharashtra</b>	<b>58,243,056</b>	<b>54,131,277</b>	<b>1,12,374,333</b>
Mumbai Suburban	5,031,323	4,325,639	9,356,962
Thane	5,865,078	5,195,070	11,060,148

Source: Census of India 2011

#### Population Density

Population density of the affected districts varies considerably as per the census data of 2011 which clearly suggests that the density of population in the project influenced area is similar to the state. Maharashtra has a population density of 365 persons/ sq. km. and in the affected districts about 20980 persons/ sq. km in Mumbai Suburban district and about 1157 persons/ sq. km in Thane district as detailed in Table 3.2.

It is also clearly evident from the data that the percentage increase in the population density of the influenced district is similar to the state. The population density of the state has increased by only 0.86% and in the affected districts population density has increased by 0.93% in Mumbai Suburban and 0.74% in Thane.

**Table 3.2: Population Density of the Affected Districts**

State/ District	Population Density		%age increase in Population Density
	2001	2011	
<b>Maharashtra</b>	<b>315</b>	<b>365</b>	<b>0.86</b>
Mumbai Suburban	19,373	20,980	0.92
Thane	851	1,157	0.74

Source: Census of India 2011

### Rural and Urban Population

In the state of Maharashtra, out of total population of Maharashtra, 45.22% people live in urban regions. The total figure of population living in urban areas is 50,818,259 of which 26,704,022 are males and while remaining 24,114,237 are females. The urban population in the last 10 years has increased by 45.22 percent.

Out of the total Mumbai Suburban population for 2011 census, 100.00 percent lives in urban regions of district. In total 9,356,962 people lives in urban areas of which males are 5,031,323 and females are 4,325,639. Similarly, in Thane district, 76.99 percent lives in urban regions of district. In total 8,514,678 people lives in urban areas of which males are 4,564,942 and females are 3,949,736.

### Sex-Ratio

Sex Ratio in Maharashtra is 929 i.e. for each 1000 male, which is below national average of 940 as per census 2011. In 2001, the sex ratio of female was 922 per 1000 males in Maharashtra. Sex Ratio in urban regions of Maharashtra was 903 females per 1000 males. For child (0-6) sex ratio the figure for urban region stood at 899 girls per 1000 boys. Total children (0-6 age) living in urban areas of Maharashtra were 5,637,563. Of total population in urban region, 11.09 % were children (0-6).

Sex Ratio in Mumbai Suburban, it stood at 860 per 1000 male compared to 2001 census figure of 822. In 2011 census, child sex ratio is 913 girls per 1000 boys compared to figure of 923 girls per 1000 boys of 2001 census data and Sex Ratio in Thane, it stood at 886 per 1000 male compared to 2001 census figure of 858. The average national sex ratio in India is 940 as per latest reports of Census 2011 Directorate. In 2011 census, child sex ratio is 924 girls per 1000 boys compared to figure of 931 girls per 1000 boys of 2001 census data. Sex-ratio of the influence districts are lower than the state as shown in **Table 3.3**.

**Table 3.3: Sex Ratio in the State and Project District**

States/District	Overall Sex Ratio	Child Sex Ratio (Age group of 0-6 yrs)
<b>Maharashtra</b>	<b>929</b>	<b>894</b>
Mumbai Suburban	860	913
Thane	886	924

Source: Census of India 2011

#### Decadal Growth Rate

It is evident from 2011 census the decadal growth rate for 2001-2011 of Maharashtra is about 15.99% which is less than the growth rate of 1991-01. Similarly, the growth rate in 2001-11 of the influenced districts is much lesser than the growth rate in 1991-01 as shown in **Table 3.4**.

**Table 3.4: Decadal Growth Rate**

State/ District	Decadal Growth Rate	
	1991-2001	2001-2011
<b>Maharashtra</b>	<b>22.57%</b>	<b>15.99%</b>
Mumbai Suburban	27.99%	8.29%
Thane	54.92%	36.01%

Source: Census of India 2011

#### Vulnerable Population

As per the Government of India guidelines, people belonging to Scheduled Castes & Scheduled Tribes, physically handicapped, women headed household, families below poverty line, disabled persons and destitute persons are to be considered as vulnerable population.

The census data, 2011 reveals that the percentage of Scheduled Caste in the influenced district is less than that of the state. With respect to Schedule Tribe population, state has 9.35% of ST population and Schedule Tribe population in the influenced Mumbai Suburban district is 1.12% and Thane district is 13.95% as detailed in **Table 3.5**.

**Table 3.5: Total Schedule Caste and Schedule Tribe**

State/ District	Total Population	SC Population	ST Population	%age of SC out of total population	%age of ST out of total population
<b>Maharashtra</b>	<b>1,12,374,333</b>	<b>13,275,898</b>	<b>10,510,213</b>	<b>11.81%</b>	<b>9.35%</b>
Mumbai Suburban	9,356,962	583,302	104,560	6.23%	1.12%
Thane	11,060,148	730,089	1,542,451	6.60%	13.95%

Source: Census of India 2011

### 3.4 The Social Services

#### Literacy and Education

Literacy rate of the influenced districts is greater than that of the Maharashtra state. Out of the affected districts, Mumbai Suburban has the higher literacy rate of 89.91% and the literacy rate of Thane District is also higher than the state literacy rate. It is also clear from the **Table 3.6**.

**Table 3.6: Literacy Rate**

State/ District	Literates Population	Literacy Rate (in %age)
<b>Maharashtra</b>	<b>81,554,290</b>	<b>82.34</b>
Mumbai Suburban	7,575,485	89.91
Thane	8,227,161	84.53

Source: Census of India 2011

### 3.5 Economic Features

#### Distribution of Population by Workers, Non-workers & Occupation

Agriculture is the main occupation of its inhabitants in the project-influenced districts. As evident from **Table 3.7**, non-workers exceed main-workers, showing relatively low dependency ratio.

**Table 3.7: Distribution of Population by Workers and Non-Workers**

State/ District	Population	Male	Female	Total
<b>Maharashtra</b>	Main Workers	29989314	13773576	43762890
	Marginal Workers	2627561	3037427	5664988
	Non- Workers	25626181	37320274	62946455
	<b>Total</b>	<b>58243056</b>	<b>54131277</b>	<b>112374333</b>
Mumbai Suburban	Main Workers	2811481	704441	3515922
	Marginal Workers	132841	86258	219099
	Non- Workers	2087001	3534940	5621941
	<b>Total</b>	<b>5031323</b>	<b>4325639</b>	<b>9356962</b>
Thane	Main Workers	3059503	871008	3930511
	Marginal Workers	303620	258636	562256
	Non- Workers	2501955	4065426	6567381
	<b>Total</b>	<b>5865078</b>	<b>5195070</b>	<b>11060148</b>

Source: Census of India 2011

**Table 2.8** contains occupational structure of work force in the project affected districts. District wise breakup suggests that occupation in other sector is greater than agriculture sector in the affected districts. All project affected districts, more than 87% of the workers are involved in other activities and rest of workers are involved in either cultivation or HH industries as shown in **Table 3.8**.

**Table 3.8: Categories of Workers**

State/ District	Categories	Male	Female	Total
<b>Maharashtra</b>	Cultivators	7592313	4977060	12569373
	Agricultural Labourers	6774538	6711602	13486140
	HH industries	690755	534671	1225426
	Other Workers	17559269	4587670	22146939
	<b>Total</b>	<b>32616875</b>	<b>16811003</b>	<b>49427878</b>
Mumbai Suburban	Cultivators	9654	6432	16086
	Agricultural Labourers	15389	5333	20722
	HH industries	78300	40516	118816
	Other Workers	2840979	738418	3579397
	<b>Total</b>	<b>2944322</b>	<b>790699</b>	<b>3735021</b>
Thane	Cultivators	203210	146721	349931
	Agricultural Labourers	216749	201255	418004
	HH industries	70201	54260	124461
	Other Workers	2872963	727408	3600371
	<b>Total</b>	<b>3363123</b>	<b>1129644</b>	<b>4492767</b>

Source: Census of India 2011

### 3.6 Social and Demographic Profile of the affected Villages

A social and demographic profile of the project-affected area/population is essential to create database and develop indicators for the evaluation of the RAP. To understand the social context of the proposed project and for providing necessary inputs for social analysis of the project, relevant baseline data on social and cultural conditions were collected from various available primary and secondary sources like personal observation and enquiry, consultation with knowledgeable persons of the villages/towns etc. Due to the implementation of project several villages or urban settlements in the affected districts of Mumbai Suburban and Thane are likely to be affected. The important demographic features of the villages/towns, i.e., population, social categories, literacy level and economy of the village are described as a part of baseline data in the following manner:

#### Population

The population composition of any village is important to anticipate the extent of project impact. Keeping in mind the importance of demographic profile, the population of the villages was computed.

The composition of population with respect to male and female population of potential affected villages/ settlements is shown in **Table 3.9**.

**Table 3.9: Distribution of the Population of Different Villages/ Town with Sex Composition**

Sl. No.	District	Name	Male	Female	Total
1	Mumbai Suburban	Greater Mumbai (M Corp.)	5031323	4325639	9356962
2	Thane	Thane (M Corp.)	975399	866089	1841488

Source: Census of India 2011

#### Social Classification

It is very important to identify vulnerable population during Social Assessment. Social survey data was applied to understand the social classification in affected settlements/ villages. The assessment of the population under different social categories in the concerned settlements/ villages is discussed in **Table 3.10**.

**Table 3.10: Social Classification in Villages**

Sl. No.	Name	Scheduled Castes			Scheduled Tribes		
		Male	Female	Total	Male	Female	Total
1	Greater Mumbai (M Corp.)	300291	283011	583302	55033	49527	104560
2	Thane (M Corp.)	65167	60836	126003	21928	20770	42698

Source: Census of India 2011

#### Educational Status

As per the Census 2011 data, the number of male literates are higher than the female literates. The **Table 3.11** delineates the literate population of the villages.

Sl. No.	Name	Literates			Illiterates		
		Male	Female	Total	Male	Female	Total
1	Greater Mumbai (M Corp.)	4223029	3352456	7575485	808294	973183	1781477
2	Thane (M Corp.)	797342	661454	1458796	178057	204635	382692

**Table 3.11: Number of Literates and Illiterates in the Project Influence Villages**

Source: Census of India 2011

#### Workforce in Project affected villages

Majority of work force belongs to the category of main workers followed by the category of marginal workforce. The details of the affected villages/towns are summarized in **Table 3.12**.

**Table 3.12: Workers in the Project-Affected Villages**

Sl. No.	Name	Main Workers			Marginal Workers			Total Workers
		Male	Female	Total	Male	Female	Total	
1	Greater Mumbai (M Corp.)	2811481	704441	3515922	132841	86258	219099	3735021
2	Thane (M Corp.)	515048	134080	649128	31138	18969	50107	699235

Source: Census of India 2011

### Category wise Distribution of Workforce

It is well evident from the below table that people of the likely affected villages are either engaged in agriculture or in cultivation work. Maharashtra is one of the industrial hub of the nation thus few of the people engaged in industrial as well as other related activities. However, agriculture does play an important sector in the engaging the workforce as is shown in **Table 3.13**.

**Table 3.13: Distribution of Workforce in Project Affected Villages**

Sl. No.	Name	Cultivators			Agricultural Labourers			Household Industries			Other Workers			Non Workers			Total Workers		Grand Total
		Male	Female	Total	Male	Female	Total	Male	Female	Total	Male	Female	Total	Male	Female	Total	Male	Female	
1	Greater Mumbai (M Corp.)	9654	6432	16086	15389	5333	20722	78300	40516	118816	2840979	738418	3456715	2087001	3534940	5621941	2944322	790699	3735021
2	Thane (M Corp.)	2957	1423	4380	3298	1412	4710	9901	7202	17103	530030	143012	643867	429213	713040	1142253	546186	153049	699235

Source: Census of India 2011

## Chapter 4: Traffic Surveys Forecast and Assignment

### 4.1 Introduction

This Chapter explains the scope, objective, methodology and findings of Traffic Survey Carried Out for Thane-Borivali Highway Tunnel (TBHT). The findings of traffic surveys have been presented in this chapter. The traffic forecasting has been carried out by econometric models and traffic assignment is done using willingness to pay responses and desire line data. The proposed new TBHT corridor is expected to connect the Ghodbandar Road to the Western Expressway via a tunnel section under the Sanjay Gandhi National Park. The study aims to document traffic volumes that would be diverted from the existing vicinity corridors to the proposed new TBHT corridor. The report also aims to identify the corresponding lane configuration required for the proposed TBHT corridor carriageway to accommodate the projected 10-year (Year 2032) 20-year (Year 2042) horizon years considering construction of the Tunnel will be completed by 2027

United Nation's Year 2014 revision of the World Urbanization Prospects report identified MMR as the second most populous urban region in India with an estimated population Of 20.7 million people in its urban agglomeration. Mumbai is connected to the national highways system by National Highway 3, National Highway 4, National Highway 8, and National Highway 17. Public transport systems in Mumbai include the Mumbai Suburban Railway, Monorail, Metro, Brihanmumbai Electric Supply and Transport (BEST), Thane Municipal Transport (TMT), Mira-Bhyander Municipal Transport (MBMT), Navi-Mumbai Municipal Transport (NMMT) buses, black-and-yellow meter taxis, auto rickshaws Private Cabs (OLA & Uber) and ferries.

### 4.2 Alignment of Proposed Road

In existing scenario, Eastern and western suburbs of Mumbai are connected through Jogeshwari-Vikhroli Link Road (JVLR) which connects Western expressway at Jogeshwari near Balasaheb Thackeray Trauma care. This road connects Seepz, Powai, and Kanjurmarg and Eastern expressway near Nehru Nagar. This road is to the south of Sanjay Gandhi National Park. Another road which connects eastern and western suburbs is Ghodbunder road. This road connects Western express Highway at Fountain Junction and passes throughout Thane west region forming the main artillery road. This road is on north and east of Sanjay Gandhi National Park, these two roads only offer connectivity to the eastern and western suburbs of Mumbai surrounding the Sanjay Gandhi National Park. MCGM has proposed Goregaon Mulund link road to enhance the present east west connectivity, but it is still in DPR stage. The proposed Thane-Borivali Highway will provide direct connectivity to the eastern and western areas surrounding the Sanjay Gandhi National Park. The alignment of the proposed road is through Sanjay Gandhi National Park. Owing to the environmentally sensitive nature of this region, the proposed alignment of the Thane-Borivali Highway would be through a tunnel under the existing forest area. West-end of the tunnel of the proposed Thane-Borivali Highway would extend up to the Western Express Highway at Magathane Junction by improvising existing jai Maharashtra Road. Magathane junction is major junction on western express highway which connects Borivali west to Borivali east. Datta pada road which forms western arm of Magathane junction further connects with FM Cariappa Flyover to cross-over western railway and joins Swami Vivekananda Road at Dr. Shyamprasad Mukherji Chowk. At Magathane junction an existing Datta pada flyover of four lane divided carriageway is provided for the through traffic on Western express highway. East of the tunnel of the proposed Thane-Borivali Highway tunnel would extend up to the

Godhbunder Road at Mulla baug Junction through a proposed widening of existing TMC DP road. Fig 4-1 illustrates the major roadway network and the proposed Thane-Borivali Highway tunnel alignment.

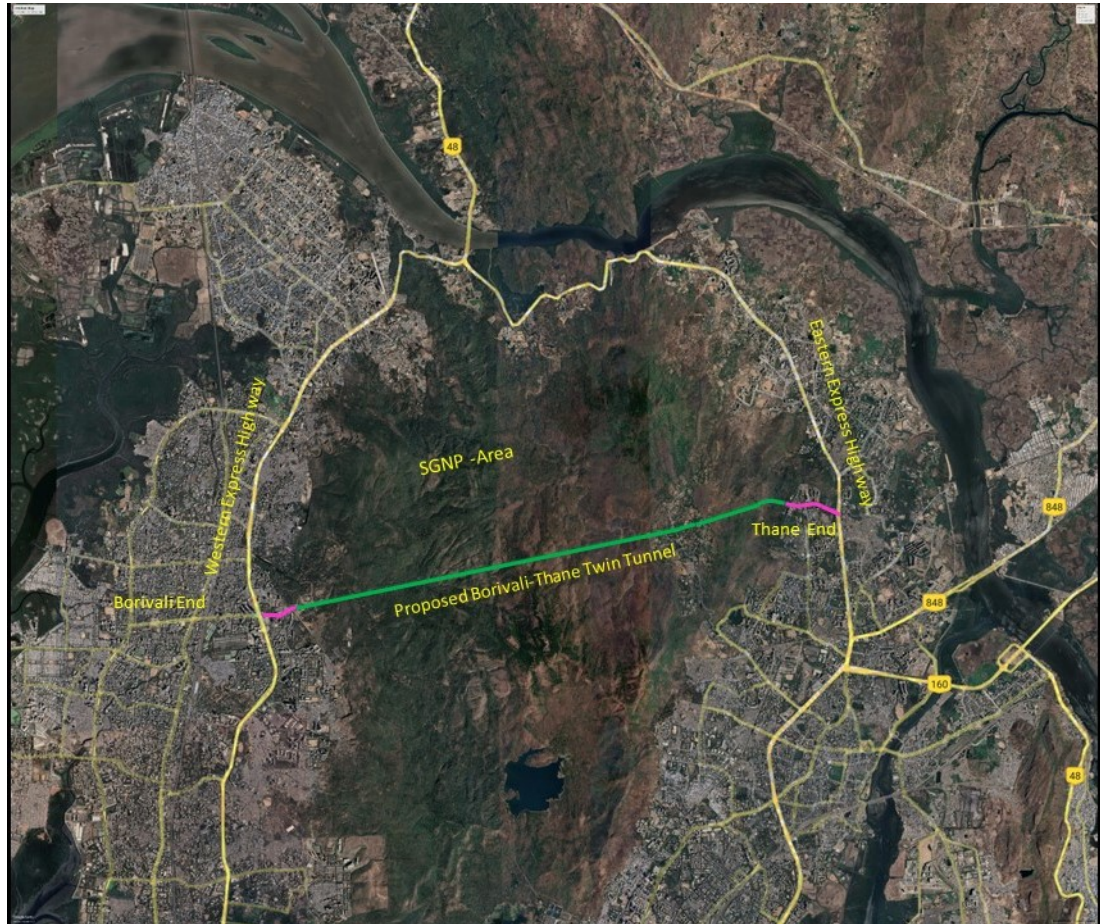
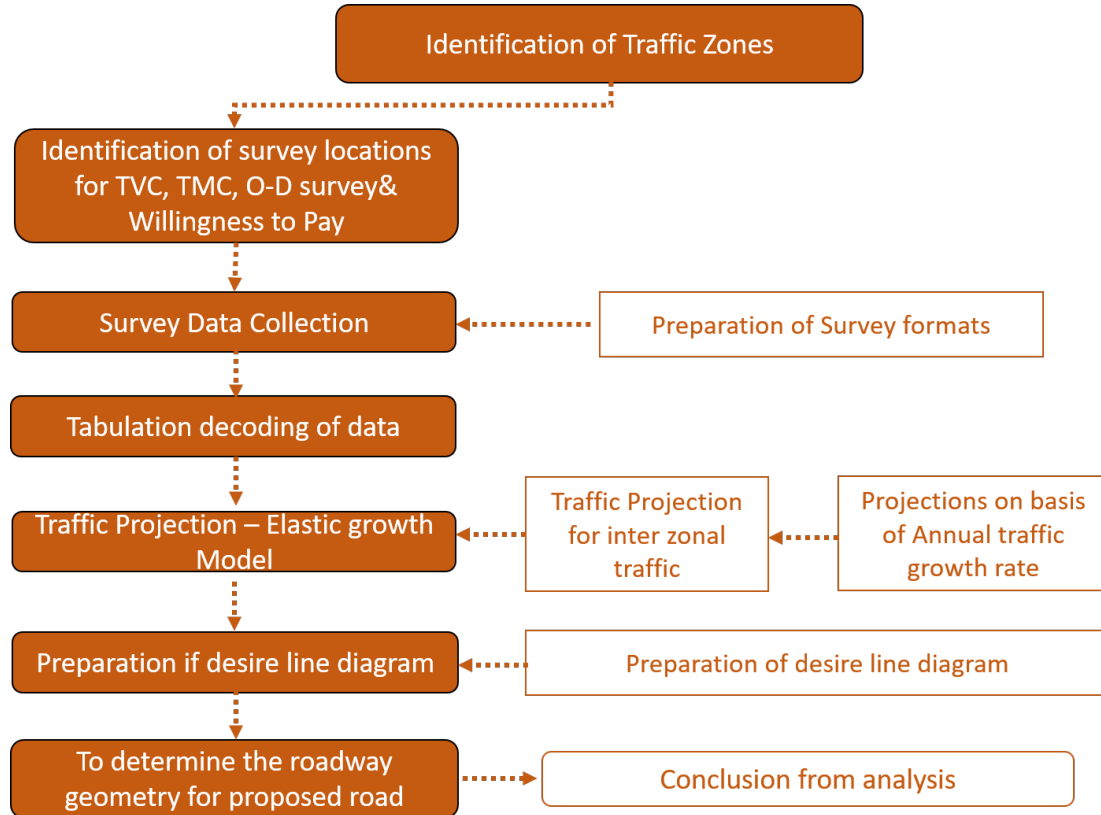

Fig. 4-1 Alignment of Proposed Thane-Borivali Tunnel

### 4.3 Methodology



### 4.2 Methodology for Traffic survey

To determine the existing travel patterns in the study area and to project the future traffic volumes onto the proposed new corridor, the vicinity areas were divided into traffic zones. The roadway network in the vicinity of the Sanjay Gandhi National Park was studied to identify the appropriate locations for data collection. The locations for traffic volume counts, Turning Movement counts, O-D surveys with willingness to pay were selected so as to capture maximum relevant data for the study in an efficient manner. Tabulation of the collected data was carried out in Microsoft excel while the preparation of desire line diagrams was carried out using flow mapper plug in QGIS software. An Elastic Demand Model was used to arrive upon the anticipated traffic projections for the future year scenarios. On the basis of these traffic projections for the year 2032, 2042 scenarios, carriageway geometry for the proposed TBHT was recommended. Figure 3-2 illustrates the methodology used for this traffic study.

#### 4.4 Types of Traffic Survey conducted for this report

- Classified Traffic Volume Count (CVC)
- Turning Movement Count (TMC)
- Origin – Destination Survey (OD)
- Willingness to Pay (WTP)
- Speed and Delay

##### **Classified Traffic Volume Count (CVC)**

We recorded the moving traffic for continuous period of seven days in the year 2018, by installing video cameras at following four locations to have clear view of the moving traffic.

1. Magathane Midblock (WEH)
2. Fountain Midblock (WEH)
3. Kapurbawdi Midblock (Ghodbunder Road)
4. Powai Midblock (JVLR)

##### Installation of the video cameras

It is important to know the traffic volume and different vehicle classes' composition in this project for strategic planning of desire tunnel Alignment. It also identifies the Average Daily Traffic, Peak Hour Traffic and its composition. We have use videography to survey the roadway volume and classification. As traffic count has to be taken at traffic signals, 2 video cameras were installed at each location for both up and down sides. In total 8 cameras were installed to carry out Traffic Volume Count. These cameras were powered with uninterrupted power supply from the nearby Traffic junction. There was provision of stabilizer as well as monitor were installed. The recording period was decided Seven days. Videos for entire seven days of all four location have been recorded in various time slot and appropriate folders were converted for each day for all eight cameras. These videos visually inspected to check for any lapses, and certified that uninterrupted recordings have been completed. Each day traffic is tabulated into the spreadsheet in hourly basis. This count is segregated into the type of the vehicle such as Cars, Trucks, MAV etc. By visually checking all 24 hours flow this data is tabulated and segregated in the in meaningful table. The classified volume counts were converted into Passenger Car Units (PCUs).

##### **Turning Movement Count (TMC)**

This survey involves capturing vehicle-turning movements and its composition in an intersection. This information is vital for Magathane Junction's Improvements, Signaling, Planning the Pedestrian Crossing etc. Also, it provides the peak hour Turning movement information. We have collected data by videography. Hourly Turning Movement counts were charted in excel sheet. These exercises were carried for Twelve-hours duration at the Magathane junction. Traffic counts were conducted on weekdays from morning peak hours to evening peak hours for 12-hours duration (800hrs-2000hrs). The peak hour volumes for both morning and evening peak hours were obtained. Junction was divided into 4 arms each arm for each direction. Further these arms were divided into 3 turnings movements "Left, Right and Through". These turning movements were further analyzed. The turning movement count were further converted into Passenger Car Units (PCUs). 4-4 below illustrates the turning movement counts at the magathane junction. Relevant data is provided in



#### 4.2 Photographs of Camera for videography installed at survey location

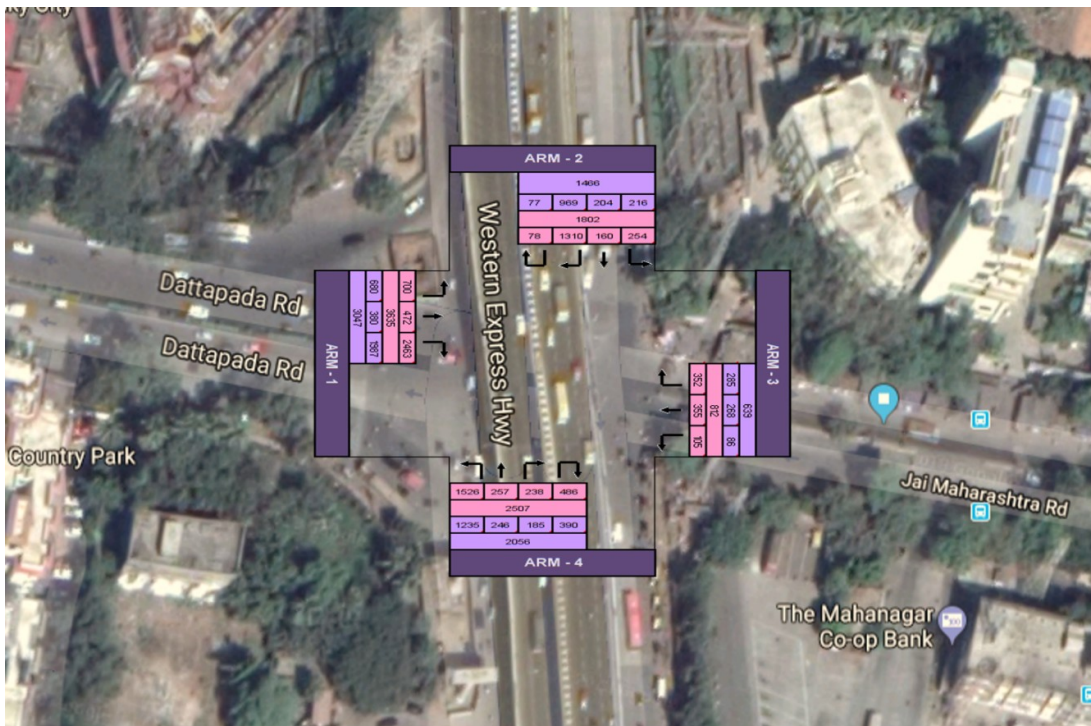
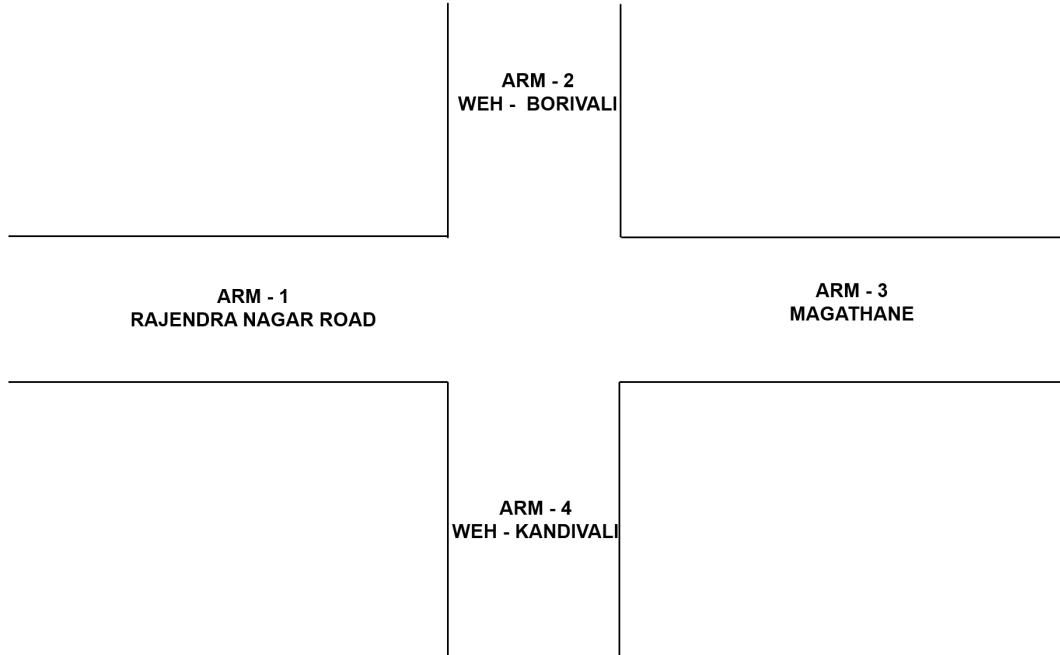

Peak Period	Total In-Flow Volume to Intersection	
	Vehicle/hour	PCU/hour
Morning Peak	8756	7208

#### 4.4 Turning Movement Count at Magathane junction

#### Origin – Destination (O\_D) Survey & Willingness to Pay

This survey identifies the travel pattern of vehicles along a road network. This survey spots where most vehicles originate in a network and finish their journey and it also shows how often they take this path. This was done using Roadside Interviews collected manually by interviewing them. In addition to the O-D survey willingness to pay questionnaire. O-D surveys & Willingness to Pay were conducted for the morning and evening peak traffic durations. These O-D surveys and willingness to pay were carried out at the following 3 locations.

1. Fountain Midblock (WEH)
2. Kapurbawdi Midblock (Ghodbunder Road)
3. Powai Midblock (JVLR)

To improve the quality of sample data being collected, every attempt was made to capture O-D data in the same proportion as the modal split observed during the classified volume counts at that particular location. We had classified Vehicles in 14 main categories and commodities into 12 Categories as elaborated in 1-5. A total of 7362 samples were collected as a part of this exercise. **Table 1** below illustrates a blank sample table that was populated in the field with information collected from the commuters

3-3 Categories considered for O-D Survey

Vehicle Type	Commodity Type
1. Two wheelers	1. Foodgrains
2. Autorickshaw (3W)	2. Fruits and Vegetables
3. Maxi Cab (3W)	3. Household Goods
4. Taxi	4. Chemicals and Fertilisers
5. Car/Jeep/Van (other than Taxi)	5. Petroleum
6. Bus	6. Building Materials
9. LCV	7. Textile
i) LCV 3 wheeler	8. Ore / Mineral
ii) LCV 4 wheeler	9. Timber
iii) LCV 6 wheeler	10. Manufactured Goods
10. 2-Axle Truck	11. Empty
11. 3-Axle Truck	12. Others (Specify)
12. Multi-Axle Truck	
13. Tractor with Tractor	
14. Tractor without Tractor	
15. Cycle	
17. Others (Specify)	



Road Side Interview Survey: Passenger Vehicle													
Location Name: _____										Sheet No: _____			
Location_ID: _____										Day: _____			
Direction: From: _____ To: _____										Date: _____			
Weather: Fine/Cloudy/Rainy										Time: _____			
S.No	Time of Interview	VehicleType	Origin	Zone	Destination	Zone	Distance/Travel Time/Travel Cost	Trip Purpose	Trip Frequency	Route Particulars/Adopted Routes	Occupancy	Ownership Of	WTP
		1. Two wheelers	Location (Village/Taluka):		Location (Village/Taluka):		Distance (km) :	1. Home (Return)	1. _____ Times per day			1. Self Owned	whether want to shift
		2. Autorickshaw (3W)						2. Work	2. Daily			2. Others (Hired)	1) Y
		3. Maxi Cab (3W)	District:		District:			3. Education	3. Weekly				<50
		4. Taxi					Travel Time (hh:mm) :	4. Shopping	4. Occasionaly				50-100
		5. Car/Jeep/Van (other than Taxi)	State:		State:			5. Business					>100
		6. Bus											
		15. Cycle	If within MMR:		If within MMR:			6. Health					
		17. Others (Specify)	Loaction:		Loaction:		Cost (Rs.) :	7. Entertainment/Recreation					2) N
			Landmark1:		Landmark1:			8. Social					
			Landmark2:		Landmark2:			9. Others (pl. specify)					
Name of Enumerator: _____										Supervisor: _____			

Table 1 Sample of O-D and Willingness to Pay Questionnaire for

### Traffic analysis zones (TAZ)

The Project Influence Area (PIA) was identified with respect to the alignment of the proposed road in the vicinity of the Sanjay Gandhi National Park. The PIA was divided into 42 traffic analysis zones (TAZs). The ward map of Greater Mumbai, map of Mumbai suburban area, and the map of Thane district were used to delineate the boundaries of the TAZs. The respective boundaries were overlaid using AutoCAD software to prepare the overall map. 4.6 & 4.7 below illustrates the TAZs. The purpose of these zones was to help analyse the nature of trips operational within the study area. These trips would later be used to calculate the traffic diversion once the proposed Thane– Borivali Highway Tunnel becomes operational.

Zone No	Zone Name
1	Gujarat
2	North West Maharashtra, Palghar, Vasai , Virar,Nalasopara
3	Kashmira
4	Mira Bhayander
5	Dahisar
6	Borivali, Gorai, Kandivali
7	Malad, Goregaon
8	Oshiwara, Jogeshwari
9	Andheri West, Andheri East
10	Vile Parle
11	Bandra
12	Island city
13	Rest of Mumbai Suburb
14	Chembur
15	kurla
16	Saki Naka
17	Powai
18	Ghatkopar
19	Vikroli
20	Kanjurmarg
21	Bhandup, Mulund, Mulund

Zone No	Zone Name
22	Kalwa
23	Naupada
24	Lokmanya Nagar, Shree Nagar
25	Majiwada
26	Kapurbawdi
27	Manpada
28	Kolshet, Vidhyapeeth
29	Brahmand, Hiranandani Estate, Patlipada
30	Kasarwadavali
31	Bhayandarpada
32	Gaimukh
33	Chena
34	Fountain
35	Rest of Thane
36	Bhiwandi
37	Kalyan, Ambernath
38	Airoli
39	Navi Mumbai
40	North East Maharashtra
41	East Maharashtra
42	South Maharashtra

#### 4.6 Zone Considered for O-D Survey

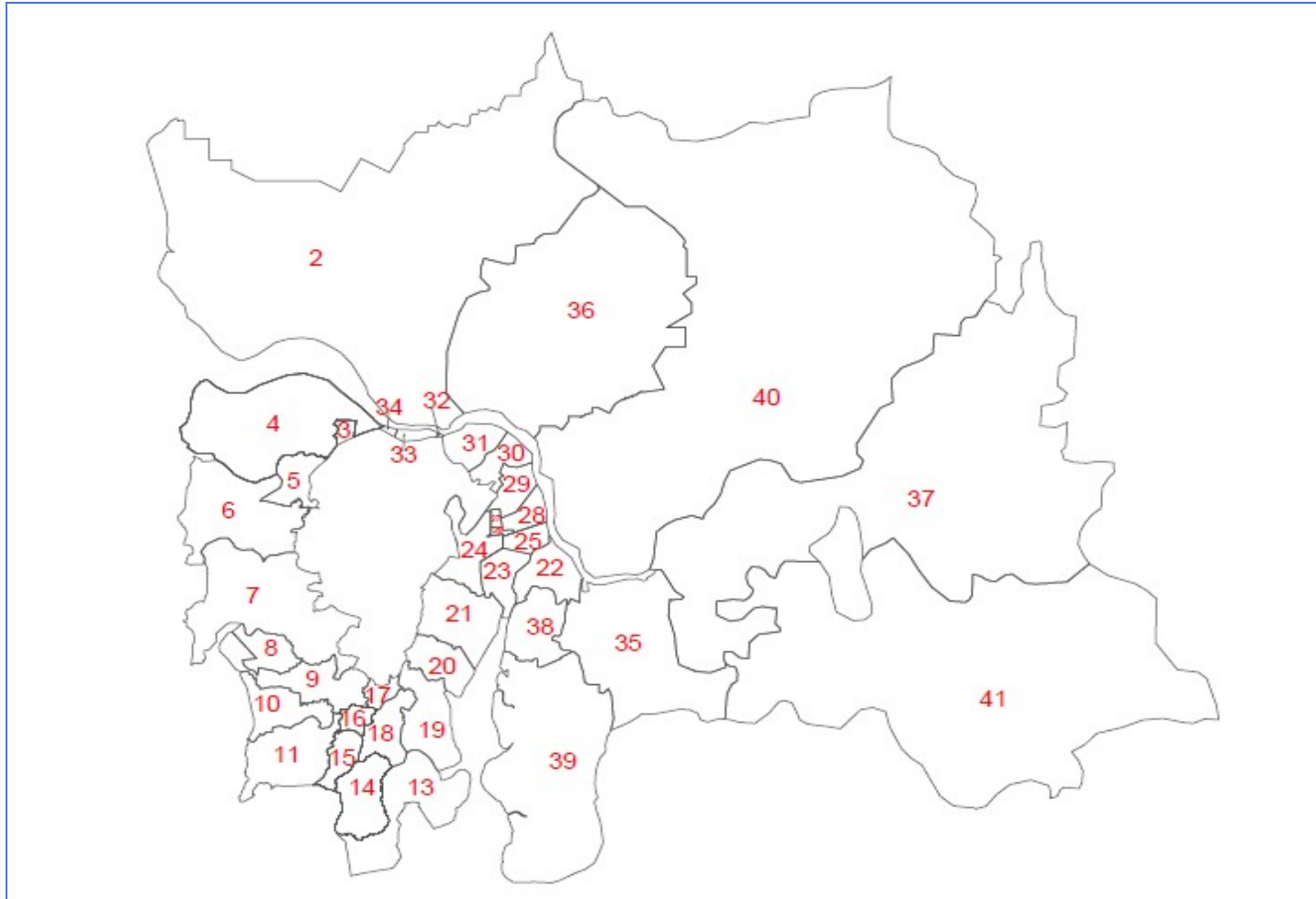



*Detail Project report for Construction of 11.85km long twin tube, 2 lanes + 1 emergency lane each highway tunnel for connecting Thane on Eastern Express Highway to Borivali on Western Express Highway in the state of Maharashtra*



---

#### 4.7 Map of Traffic Analysis Zone

### Speed and Delay

The speed and delay survey were conducted using the moving observer method. It was conducted for the entire section starting from magathane to Tikujiniwadi via Ghodbunder road to Magathane via JVLr and Vice-versa. The test vehicle was run at the perceptible average speed of the traffic stream along the project road so that the number of vehicles overtaken by the test vehicle equaled the number of vehicles overtaking the test vehicle. The observers inside the test vehicles recorded the travel time and stopping delay timings along with the causes of delays. The test vehicle was made to travel on both directions of travel covering three different time zone Morning afternoon and evening flow conditions on the project road.

### 4.5 Traffic Survey details



### 4.8 Survey Identified for Traffic Study w.r.t. Proposed TBH Tunnel Alignment

Video Graphic Classified Traffic Volume counts were conducted on 4 location, Classified turning Movement was conducted at 1 location, Origin-Destination surveys along with willingness to pay were conducted at 3 locations in the vicinity of the Sanjay Gandhi National Park and Speed &

Delay between both the portal locations in Peak and Non-Peak Hours to & fro. The locations were selected to assist in determining the existing traffic volumes and travel patterns operating in the study area corridor network. **Figure 4-8** illustrates the locations of the study of junctions and Mid-blocks.

### Location 1 (Magathane Junction)

Location 1 is located on Western Express Highway where Dattapada road (3-9) meets with the Western Express Highway from west and Jai Maharashtra Road meets from East. Four-way traffic at the junction was considered, which includes the traffic on Dattapada Road, Jai Maharashtra Road and service lanes of Western express highway (4-9). With reference to the zone map, this junction is located in zone 6. **Classified Traffic Volume Count (CVC1) was conducted on Dattapada Road** and Turning movement count was carried out at the Junction. This Location will be act as a starting/Ending point for Speed and Delay.

#### 4.9 Location plan for TMC and CVC-1



**Location 2 (Near Fountain Hotel)**

Location 2 is a mid-block located on western express Highway. Two-way traffic at western express highway (4-10) was considered. With reference to the zone map, this Location is located in zone 3. Classified Traffic Volume Count was conducted on Western Express Highway. O-D and Willing ness to Pay were carried out on this Location

4.10 Location for CVC-2

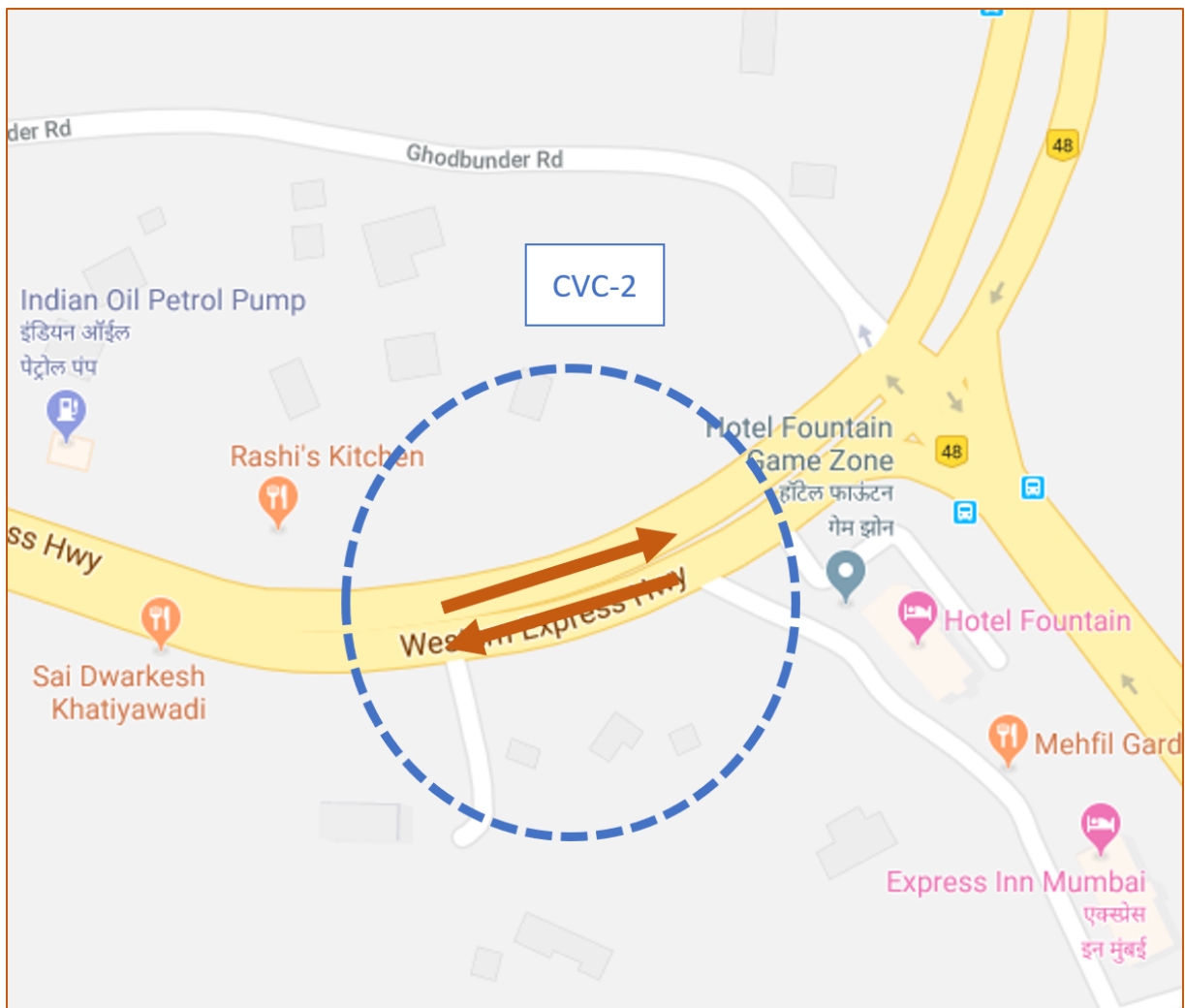

### Location 3 (Kapurbawdi)

Location 3 is a mid-block located on Ghodbunder Road, Thane. Two-way traffic at Ghodbunder Road (4-11) was considered. With reference to the zone map, this location is located in zone 26. Classified Traffic Volume Count was Conducted on Western Express Highway. O-D and Willingness to Pay was carried out on this Location. This Location will act as a starting/Ending point for Speed and Delay.

#### 4.11 Location for CVC-3

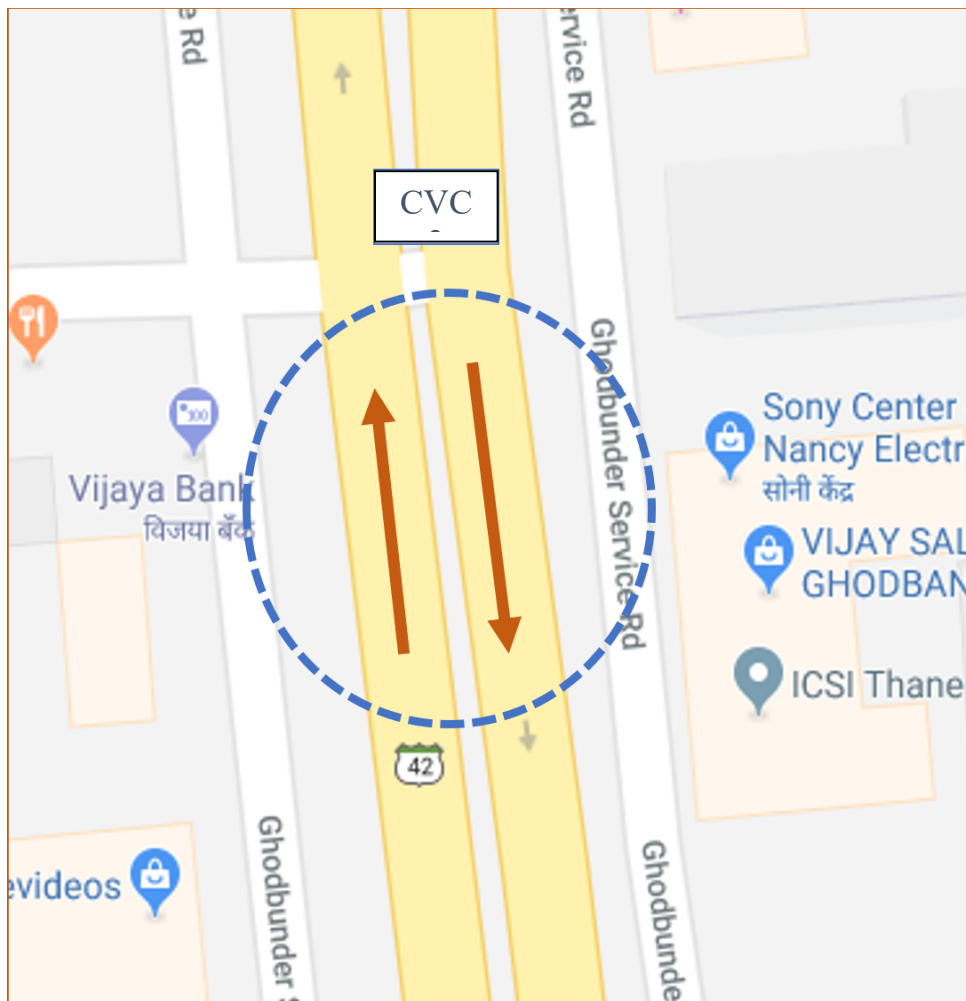

### Location 4 (Powai)

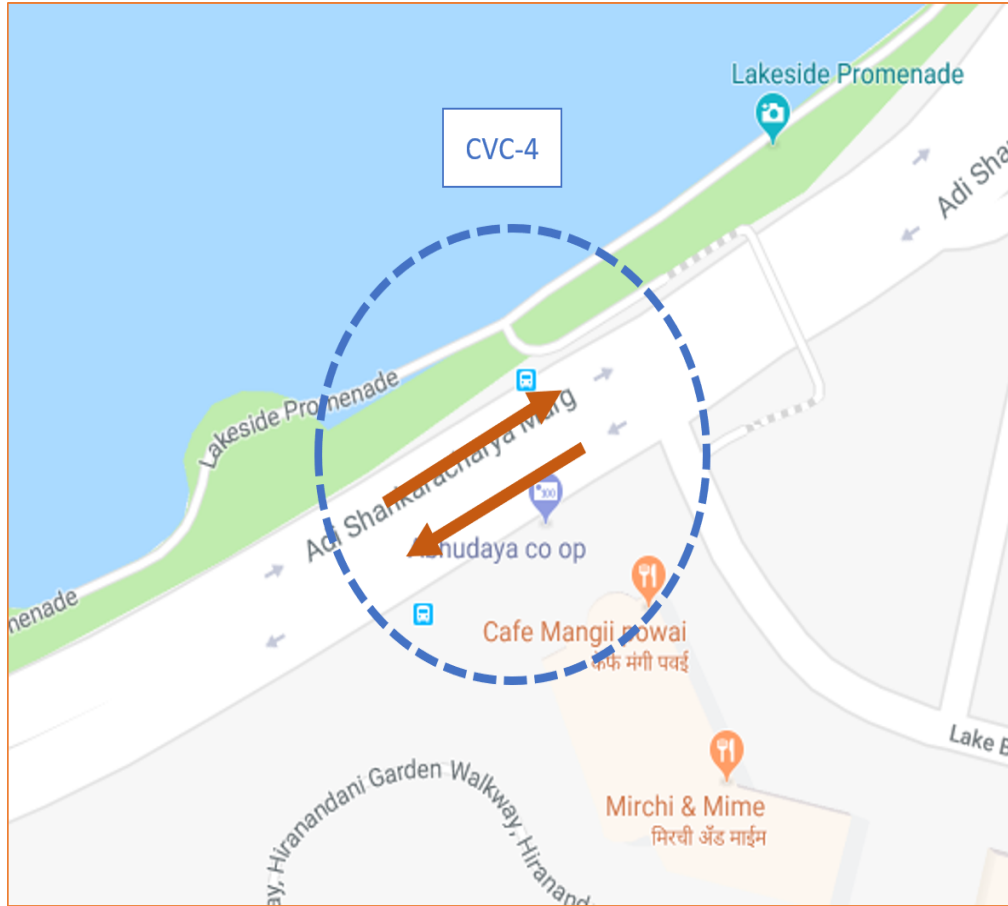

4-12 Location for CVC-4

Location 4 is a mid-block located on Jogeshwari-Vikroli Link Road (JVLR). Two-way traffic at Jogeshwari-Vikroli Link Road (JVLR) (4-12) was considered. With reference to the zone map, this location is located in zone 17. Classified Traffic Volume Count was Conducted on Western Express Highway. O-D and Willingness to Pay was carried out on this Location

#### 4.6 Data analysis

The data collected from the Classified Volume Count (CVC), Turning Movement Count (TMC) origin destination surveys and Willingness to Pay was analyzed using Microsoft Excel and QGIS (Flow mapper) software. QGIS is a geographic information system based software used for working with maps. It is generally used for creating and using maps, compiling geographic data, analyzing mapped information and managing geographic information for database sharing. As mentioned earlier, QGIS software was used for preparation of desire line diagram consistent with the methodology adopted for this project.

### Traffic volume count and trips generated

The Classified volume counts (CVC) data obtained from 24 hours for 7 Days of is summarized below in **Table 2**. The Classified volume counts are significant to ascertain the travel behavior of trips corresponding to the respective modes.

**Table 2 Traffic volume at four Mid Blocks for Base Year**

TRAFFIC VOLUME (AADT) in Veh/Day									
Locations (Mid Blocks)	2-Wheelers	3-Wheelers	4-Wheelers	LCV	Trucks	Bus	Other	Total Volume (both direction), AADT(Veh/Day)	Traffic
1	29164	39178	27887	3862	1963	1334	1152	104540	
2	30932	23579	52542	11229	8043	3276	87	129688	
3	49241	29379	72653	9493	10100	7138	250	178254	
4	50282	36410	74579	7586	2942	6748	171	178718	

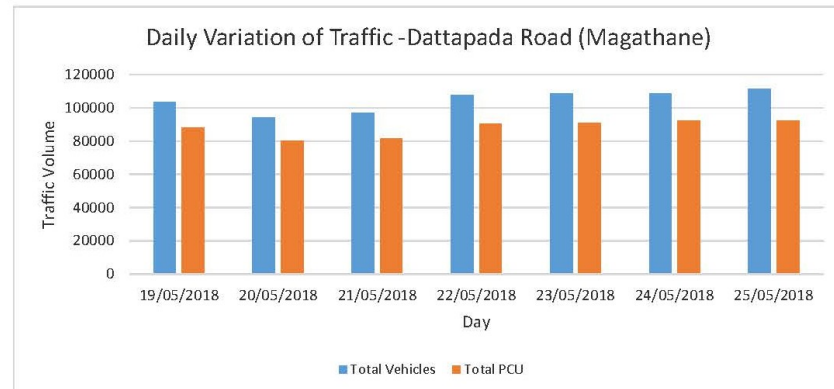
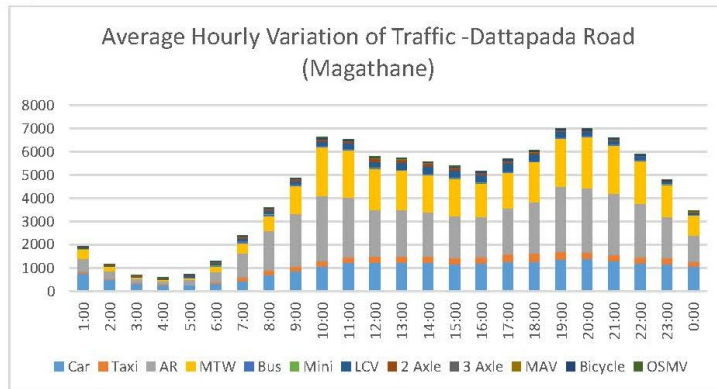
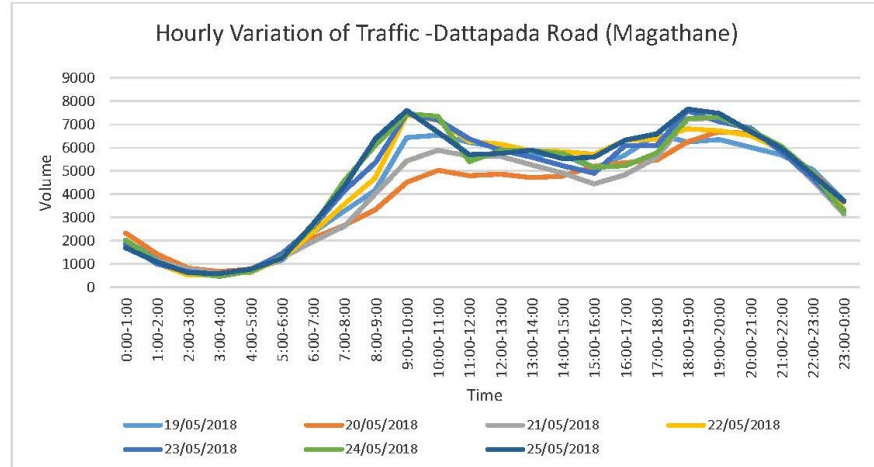
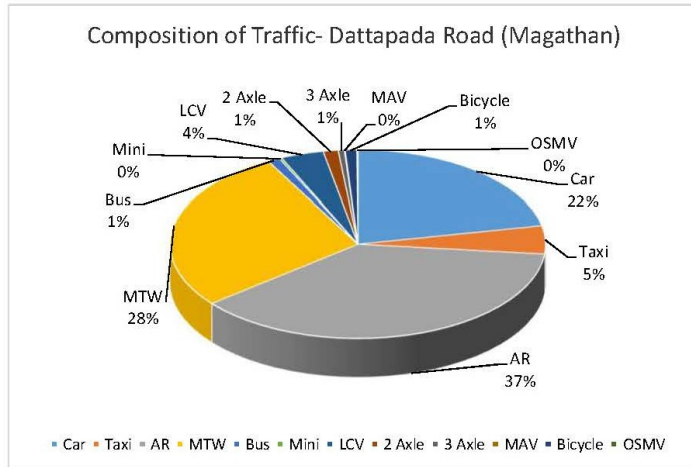

#### 4-4 Graphical representation of CVC-1 located near Magathane on Dattapada Road

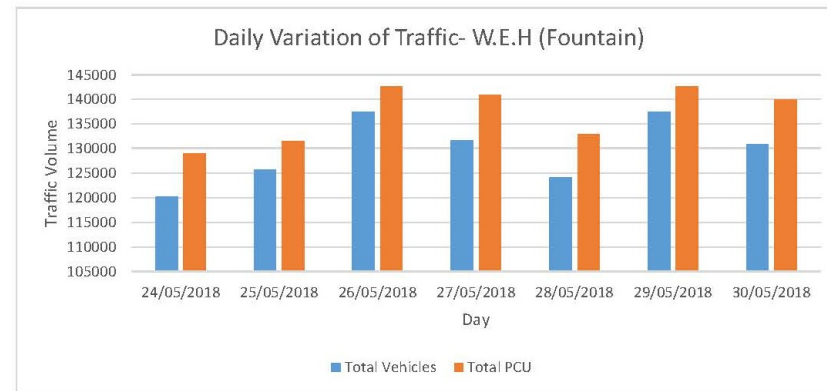
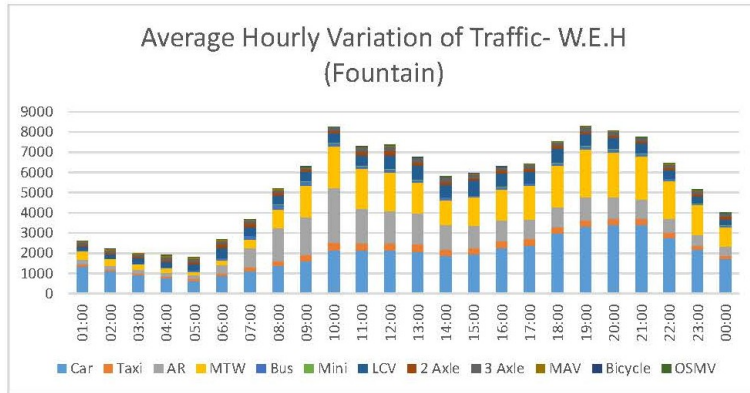
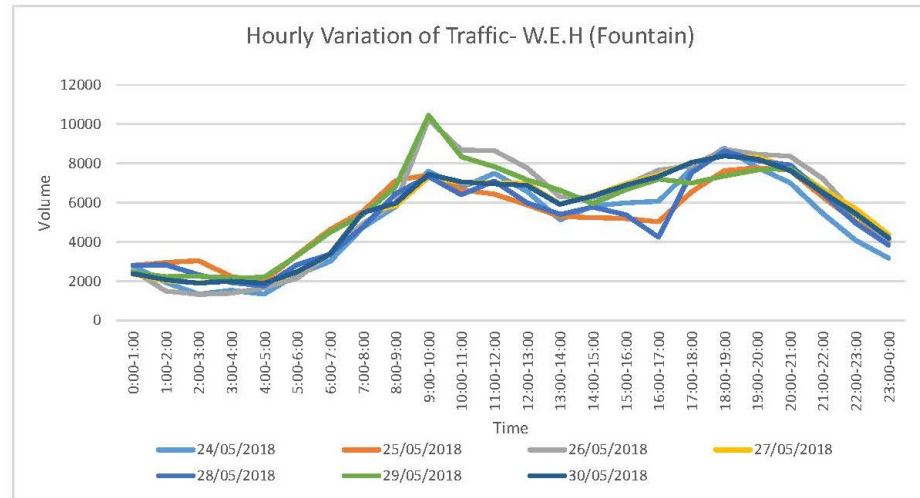
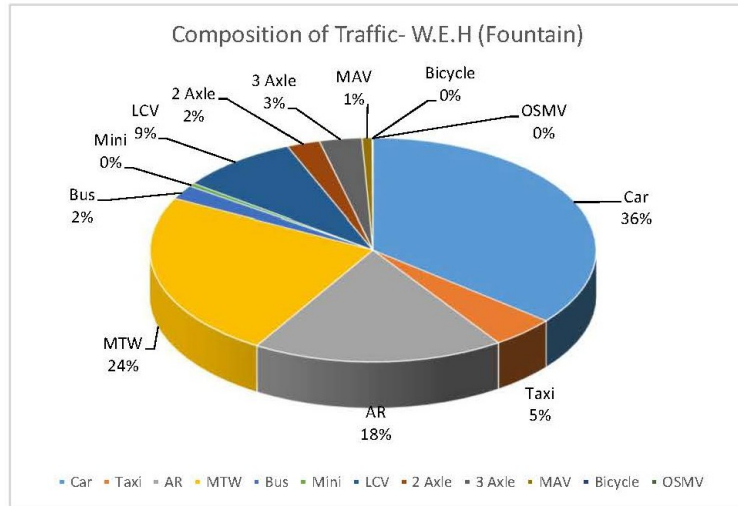

4-5 Graphical representation of CVC -2 located near Fountain hotel on WEH

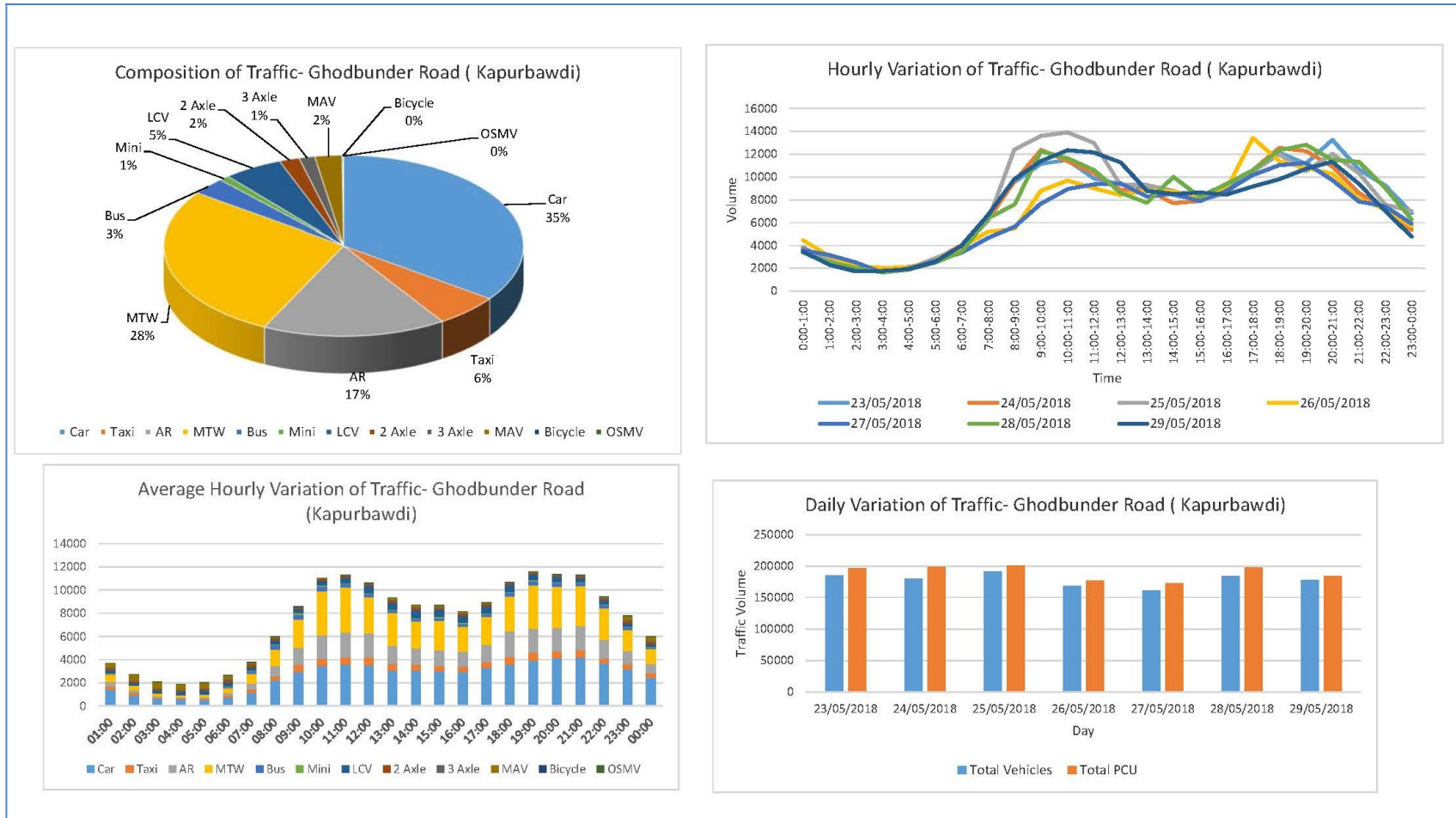

3-6

Graphical representation of CVC-3 located near Kapurbawdi, Ghodbunder

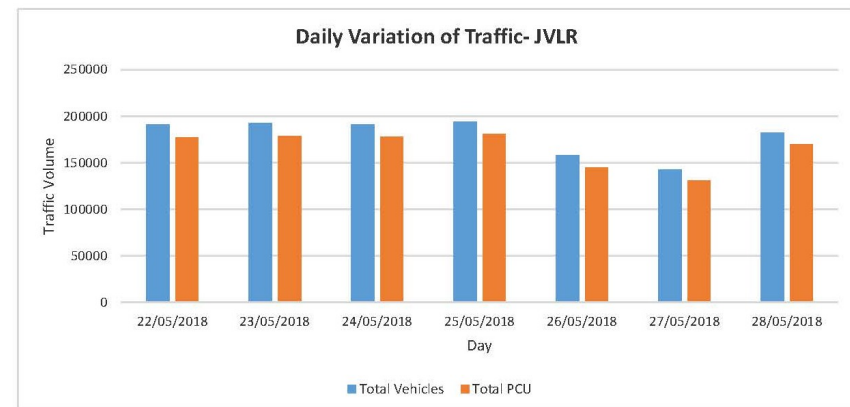
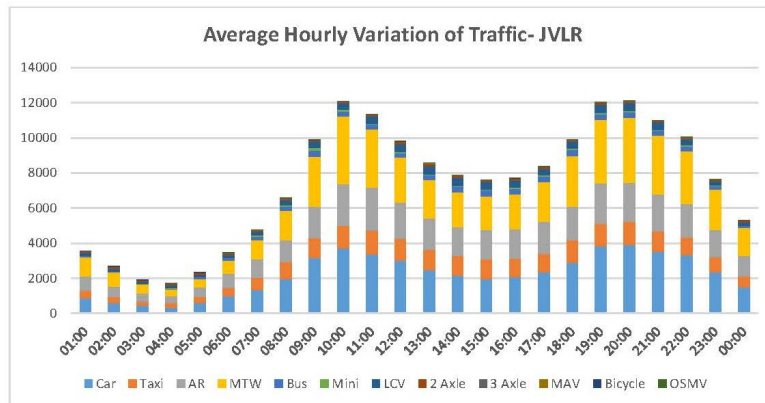
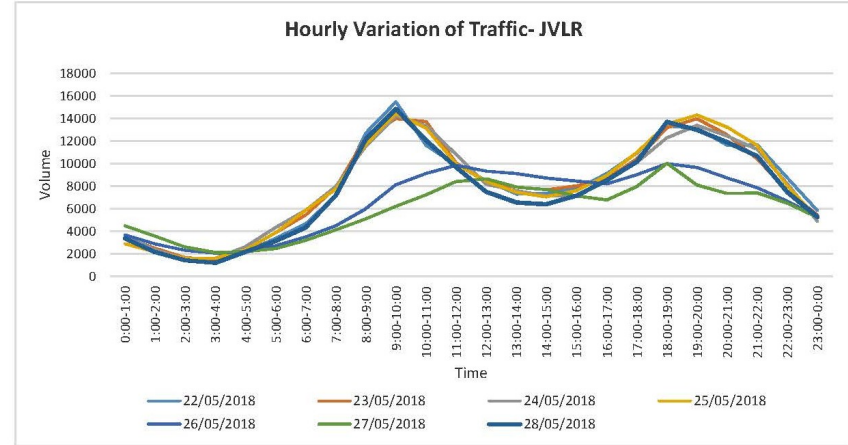
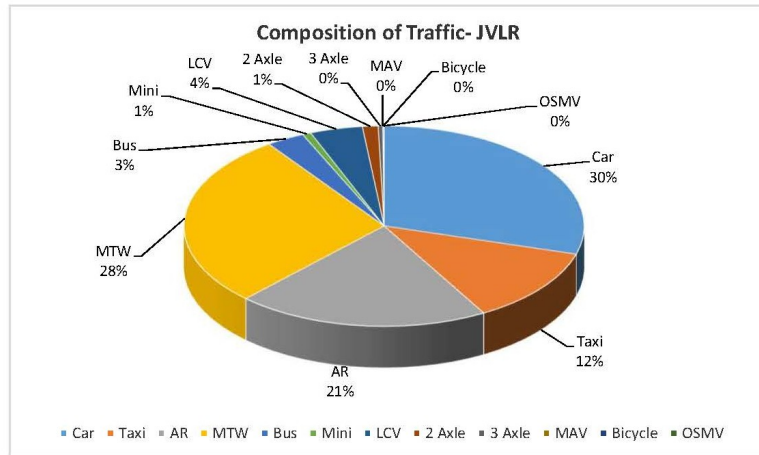

Road

#### 4-7 Graphical representation of CVC -4 located near Powai on Jogeshwari Vikroli Link Road

**Table 3** summarizes the total traffic volume during the peak hour for each location. The hourly volume at each junction was used for calculating the average daily traffic at each junction. Based on IRC 106 the peak hour volume was considered to be 8% of the annual average daily traffic.

**Table 3 : Total traffic volume at peak hour**

TOTAL TRAFFIC VOLUME OF PEAK HOUR (PCU)	
Junction	Peak Hour Volume (PCU)
1	8685
2	10886
3	14015
4	14998
Total	48584

The traffic volumes were converted into trips in PCU's. **Table 4** below summarizes the average passenger car units as per IRC 106.

**Table 4 : Passenger Car Unit**

Passenger Car unit (PCU's)						
Mode of Vehicle	2-Wheelers	3-Wheelers	4- Wheelers	LCV	Trucks	MAV
PCU's	0.5	1	1	1.5	3	4.5

**O-D Matrix for existing scenario**

Based on the total vehicles interviewed during roadside O-D survey, the origin destination matrix for the corresponding trips were prepared using Microsoft Excel. This matrix was converted into an O-D matrix in terms of PCU's using the traffic volume count for 24hours for 7days. For collecting the data in O-D survey approximately 10% sample size was maintained.

*Desire line analysis*

A desire line analysis is a tool used for determining the level of interaction between zones. In case of traffic studies, the level of interaction is generally in terms of the number of trips between the Traffic Analysis Zones (TAZs).

In this study the desire line analysis was performed to determine the number of trips between the TAZs obtained from the origin and destination survey.

A desire line diagram was prepared using the Network analysis tool in QGIS software. The steps followed for preparation of desire line diagram were as follows:

- Flow Mapper Plugin of QGIS
- Mapping of zones and creation of Shape file showing zones.
- Using OD matrix and Co-ordinated of each zone for creation of desire lines.
- Assigning values of number of trips to desire lines.

**Figure 4.16** below shows the desire line diagram based on 24-hour trips. It illustrates the trips between the zones of the study area. The centroids of the respective zones are denoted as per traffic flow, Green nodes denotes zones having gaining flow (Incoming is greater than outgoing), red nodes denote zones having losing flow (Incoming is lesser than outgoing) and grey nodes denote zones having neutral flow (Incoming is equal to Outgoing). The thickness of the lines determines the number of trips between the zones. Magenta lines denote higher number of trips. The following figure 4.16 indicated desire line diagram which has been developed for O-D survey conducted at kapurbawdi location.

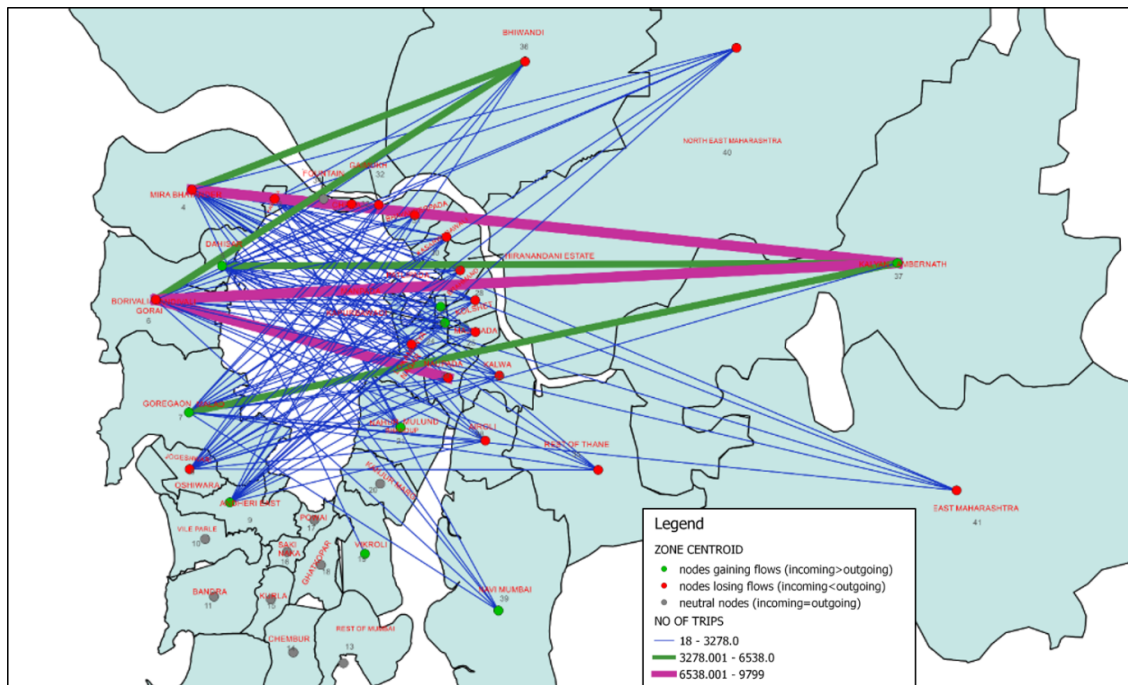

4-8 Desire line diagram for O-D survey conducted at kapurbawdi

### Analysis of Speed and Delay

Speed and delay survey data has been analyzed to obtain information on the journey speed and running speed on the different sections of project road. Below Table shows journey and running speed estimated on the sections of the project road

S.No.	Route	Time	Distance (Km)	Journey Time (mins)	Delay (min)	Journey Speed (Km/hr)	Running Speed (Km/Hr)	Reason for Delay
-------	-------	------	---------------	---------------------	-------------	-----------------------	-----------------------	------------------

S.No.	Route	Time	Distance (Km)	Journey Time (mins)	Delay (min)	Journey Speed (Km/hr)	Running Speed (Km/Hr)	Reason for Delay
1	Magathane – Tikujiniwadi via Ghodbunder- Magathane Via JVLR	8-00 to 11.30	55.9 Km	198.8	78.03	16.87	27.77	Traffic Congestion on EEH and JVLR and Near Fountain jn
2		13.00 to 15.30		135	20.95	24.84	29.4	Traffic Congestion Near Fountain Jn.
3		17.30 to 20.30		173.8	25.35	19.29	22.59	Traffic Congestion on WEH, Ghodbunder rd, JVLR and Near Fountain jn
4		8-30 to 12.00		218	41.7	15.39	19.02	Traffic Congestion on WEH, JVLR and Near Fountain jn
5		13.30 to 16.00		149.7	23.9	22.41	26.68	Traffic Congestion on WEH, and Near Fountain jn
6		18.00 to 22.30		268.3	75.9	12.5	17.44	Traffic Congestion on WEH, Ghodbunder rd, JVLR and Near Fountain jn

#### 4.7 Traffic projections

Elastic Travel Demand Modelling was undertaken for estimating the future year scenario. In this method, the growth rate was obtained by considering factors like GSDP, NSDP, Population, PCI by regression analysis. The growth factors based on elasticity of transport demand were calculated by plotting of log NSDP versus log registered vehicles for Commercial vehicles and log PCI versus log registered vehicles for passenger vehicles as per IRC standards. Elasticity was calculated with the help of population, registered vehicles and NSDP.

Using this method, the growth rates were calculated which are indicated in **Table 6**.

**Table 6 Proposed Growth Rates**

Year	Two Wheelers	Rickshaws	Four Wheelers	Buses	Trucks
2018-22	9.00%	5.50%	7.50%	7.00%	9.00%
2023-26	7.90%	5.00%	6.80%	6.60%	8.50%
2027-30	7.00%	4.80%	5.80%	6.40%	8.20%
2031-34	6.80%	4.20%	5.40%	6.15%	7.90%
2035-38	6.20%	3.60%	5.00%	6.00%	7.60%

2039-42	5.50%	3.20%	4.80%	6.90%	7.00%
---------	-------	-------	-------	-------	-------

The traffic which diverts to proposed tunnel for the base year (2018) has been calculated on the basis of Willing ness to pay under two criteria i.e. **Without GMLR** and **With GMLR**.

Various toll scenarios were analysed and following have been summarized in this report

SR. NO.	WTP(₹)		AADT
	PASSENGERS	GOODS	
<b>1</b>	With GMLR		
<b>1.1</b>	<b>NO TOLL</b>		<b>47462</b>
	<b>WITH TOLL</b>		
<b>1.2</b>	<50	300-500	<b>26056</b>
<b>1.3</b>	50-100	300-500	<b>8379</b>
<b>2</b>	Without GMLR		
<b>2.1</b>	<b>NO TOLL</b>		<b>87057</b>
	<b>WITH TOLL</b>		
<b>2.2</b>	<50	<b>300-500</b>	<b>47793</b>
<b>2.3</b>	50-100	300-500	<b>15368</b>

Determination of roadway geometry for proposed road

#### With GMLR:

- **Scenario 1.1 (No Toll Scenario)**

It can be seen that under this Scenario two lanes are required till 2026, 3 lanes will be sufficient till 2032, and after 2032 more than three lanes will be required.

- **Scenario 1.2 (Goods 300-500 & Passengers <50)**

It can be seen that under Scenario 1.2 (With GMLR) two lanes are sufficient till 2035, 3 lanes will be sufficient till 2042.

- **Scenario 1.3 (Goods 300-500 & Passengers 50-100)**

It can be seen that under Scenario 1.3 (With GMLR) two lanes will be sufficient throughout.

#### Without GMLR:

- **Scenario 2.1 (No Toll Scenario)**

It can be seen that under this Scenario three lanes will be sufficient till 2023, and after 2023 more than three lanes will be required.

- **Scenario 2.2 (Goods 300-500 & Passengers <50)**

It can be seen that under Scenario 2.2(Without GMLR) two lanes are sufficient till 2026, 3 lanes will be sufficient till 2032 and after 2032 more than three lanes will be required.

- **Scenario 2.3 (Goods 300-500 & Passengers 50-100)**

---

It can be seen that under Scenario 2.3(Without GMLR) two lanes will be sufficient throughout.

#### 4.8 Conclusion:

It can be seen from Desire Line Diagrams that a large number of traffic from central areas like Kalyan, Ambernath, Navpada, Bhivandi, Rest of Thane area would go to western areas like Borivali, Kandivali, Goregaon, Malad, Jogeshwari, Oshiwara, Andheri, Gorai, Mira, Bhayander, Similarly considerable traffic is also expected from Kalwa, North East Maharashtra, Nahur, Mulund, Gaimukh, Kolshet etc to western areas as mentioned above. Areas like Brahmmand, Airoli, Vikroli, Majiwada etc also contribute trips to western areas.

In Future Goregaon – Mulund link Road (GMLR) is one of the parallel facilities which is coming up parallel to Thane – Borivali Tunnel road. Due to this facility substantial traffic from Navi Mumbai, East Maharashtra area, Kalyan, Ambernath, Bhiwandi, Airoli,, Kalwa, Navpada etc. would shift to GMLR.

**Passenger traffic is very high as compared to Goods traffic and also it is very sensitive to toll as indicated in our Willingness to Pay Toll survey. In view of this traffic projections have been carried out in various toll scenarios. It is proposed to widen the existing Thane – Ghodbandar road by MSRDC, moreover after diversion of traffic to TBHT the level of service on Thane Ghodbandar Road will improve. Hence after studying various toll scenarios, it can be concluded that three lane (2+1) tolled carriageway for either direction would be an ideal choice.**

## Chapter 5: Engineering Surveys and Investigation

### 5.1 General

This Chapter is prepared to bring out Engineering Surveys and Geotechnical investigation. Our findings and views are presented in a concise manner but comprehensively addressing all aspects of TOR and our recommendations after discussing with MMRDA authorities.

### 5.2 Alternative Alignment studies

After the options are prepared, following salient techno-economic parameters were evaluated and the Options were compared against each individual parameter:

- Length of tunnel
- Horizontal Geometry
- Tunnel portal locations including construction space requirement
- Alignment and length of construction approaches roads at portal
- approach road's alignment and length (at grade/elevated)
- Least interference with the SGNP boundary
- Approx. Civil Cost

For rough assessment of cost of different alternatives, data regarding cost of various construction activities in general and cost of similar projects are compared.

	Option 1	Option 2	Option 3
Proximity to eco-sensitive area	> 95% of total proposed alignment is within SGNP. However, no National park land required for the construction.	> 95% of total proposed alignment is within SGNP. However, no National park land required for the construction.	> 95% of total proposed alignment is within SGNP. However, no National park land required for the construction.
Land availability for development of portal/ Cut n cover	Private/ Government land on Western side and Government (Defence) land on Eastern side	Private/ Government land on both Western and Eastern side	Private/ Government land on Western side and Government (Defence) land on Eastern side
Topography and Land use	The proposed western end location is on the border of SGNP (north-western	The proposed western end is far away from the National park boundary and is a habituated land at present.	The proposed western end is far away from the National park boundary and is habituated at present.

	Option 1	Option 2	Option 3
	corner). The topography of the area undulating rocky area sloping towards north west direction. Eastern portal is outside the SGNP. Open land parcel sloping towards eastern direction.	However, there is a redevelopment plan of BMC of the region. The proposed eastern end also lies outside the National park. The topography along the alignment is undulating on a hilly terrain under green cover.	However, there is a redevelopment plan of BMC of the region. The proposed eastern end lies outside the National park in the defence land. The topography along the alignment is undulating on a hilly terrain under green cover.
Approx. Length of proposed alignment with approaches(km)	12.56 km	11.85 km	9.68 km
Road length (without Tunnel length)	4.5 km	1.7 km Minimum road length creating minimum impact on the at-grade features, properties, etc.	3.1 km
Tunnel length	8.06 km	10.2 km Maximum tunnel length shall create minimum hindrance to the life and property on ground.	6.58 km
Ground Elevation Approx. m above msl	397 m (max.)	295 m (max.)	470 m (max.)
Portal Location	Both western and eastern portal outside the National Park.  Access to highway 3+3 lane not available on Western side due to densely populated urban area of Dahisar.	Both western and eastern portal outside the National Park.  Availability of land for both portal locations and Construction yard. Direct connection to existing DP Road.	Both western and eastern portal outside the National Park.  Unavailability of sufficient overburden on Eastern Portal. Access road on eastern side passes through dense urban area of Vartak Nagar.
Proximity to eco-sensitive area	> 95% of total proposed alignment is within SGNP. However, no National park land required for the construction.	> 95% of total proposed alignment is within SGNP. However, no National park land required for the construction.	> 95% of total proposed alignment is within SGNP. However, no National park land required for the construction.

	Option 1	Option 2	Option 3
Population Density	No population along the proposed alignment.	Significant population of slum area at the Western end outside the National Park at present which is the part of BMC's redevelopment plan. Developing residential societies of Patlipada near eastern end.	Significant population of slum area at the Western end at present which is the part of BMC's redevelopment plan.  Population along the proposed alignment above Yeyoor hills
Direct Connectivity to National Highway	Connectivity to NH8 on western side through elevated structures and Pokhran road on eastern end through access roads.	Direct Connectivity to NH8 and Thane Ghodbunder road at both western and eastern end respectively through Cut n cover / access roads.	Direct Connectivity to NH8 and Pokhran road number 2 at both western and eastern end respectively through Cut n cover.
Proximity to identified water Sources and the disturbance to the environment	Alignment is crossing one identified stream flowing from south to north in the middle east of the National Park. However, the alignment is proposed to be underground within the National Park limits in order not to affect any of the surface features and the habitation.	Alignment is crossing one identified stream flowing from south to north in the middle east of the National Park. However, the alignment is proposed to be underground within the National Park limits in order not to affect any of the surface features and the habitation.	Alignment is crossing one identified stream flowing from south to north in the middle east of the National Park. However, the alignment is proposed to be underground within the National Park limits in order not to affect any of the surface features and the habitation.
Loss of agricultural land	No agricultural land involved	No agricultural land involved	No agricultural land involved
Proximity to ASI sites and religious structures	No	No	No

The 2<sup>nd</sup> option (Chosen) of the alignment is proposed to start from Thane – Godbunder road at Patlipada Junction to Magathana Junction. This alignment will have construction of approximately 10.25 km of tunnel and about 1.6 kms approach roads to tunnels either sides.

---

In this second option, the defense land is totally eliminated and approach road (40 m DP) on Patlipada is proposed to be developed by THANE MUNICIPAL CORPORATION. Hence Option 2 was recommended by MSRDC vide letter No. MSRDC/02/JMD( 1) / Tikujiniwadi/2016/6418 is enclosed in the DPR



Alternative Alignments

	Direction	West Portal(WP) co-ordinates (approx.)	East Portal(EP) co-ordinates (approx.)
Option-1	WP1 to EP1	275978.98m E, 2126777.70m N	285018.34m E, 2125956.58m N
Option-2	WP1 to EP2	275978.98m E, 2126777.70m N	286422.49m E, 2128869.11m E
Option-3	WP2 to EP1	276674.31m E, 2128661.61m N	285018.34m E, 2125956.58m N

### 5.3 Recommended Alignment

The recommended alignment of twin tube tunnel starts from Western Express Highway (WEH) near Magathane Bus depot, passes through existing Jai Maharashtra Road and DP Road, and enters into Sanjay Gandhi National Park to pass it underground and exit near TMC park, and further follows existing roads to end on Thane-Ghodbandar Road near Patlipada.

The approximate length of the alignment from WEH to Thane Ghodbandar Road is about 11.8 Km, of which the Borivali side approach through the existing road network from WEH is about 0.6km, the length of underground tunnel is about 10.25 km between the two portals i.e., Borivali side portal and Thane side portal, and Thane side approach is about 1km up to the end point on Ghodbandar road. While the Western portal i.e., Borivali side of tunnel is located at end of DP road (outside the SGNP boundary) which is the extension of Jai Maharashtra Road and the Eastern portal i.e., Thane side is located near TMC park (outside the SGNP boundary).

The approaches and underground tunnel are proposed with 2+2 lanes with an additional emergency lane on both sides. The approaches on both sides of the tunnel will be open cut to raise the underground tunnel to the ground. To facilitate crossover from one side to another side and to serve the areas on both sides which are fully built-up two overpasses are proposed over the open cut approaches. Also, Service roads are proposed at-grade on both sides of these open cut approaches, which will serve the local traffic in this stretch and the two overpasses will get connected.

Open Road Toll System is proposed for the project with provision of one cash lane. The end intersections with Major Highways and other intersections to be formed with local roads in-between along the length of approaches are proposed for improvement/development considering the increased traffic generated/diverted due to the tunnel link.

The 2nd option (Chosen) of the alignment is proposed to start from Thane – Godbunder road at Patlipada Junction to Magathana Junction. This alignment will have construction of approximately 10.25 km of tunnel and about 1.6 kms approach roads to tunnels either sides.

In this second option, the defense land is totally eliminated and approach road (40 m DP) on Patlipada is proposed to be developed by THANE MUNICIPAL CORPORATION. Hence Option 2 was recommended by MSRDC vide letter No. MSRDC/02/JMD( 1) / Tikujiniwadi/2016/6418 is enclosed in the DPR

The recommended Alignment for tunnel proper and its approaches on either end is shown below.



### Alignment Design

The design of the alignment and geometric cross section is based on the following Indian Codes and Standards supplemented by the International Codes and Standards wherever the former is silent and the design standards developed for the project. The Design Codes Related to Tunnel and Approach Road are:

IRC: SP: 19-2001	Manual for Survey, Investigation and Preparation of Road Projects
IRC- 86 – 2018	Geometric Design Standards for Urban Roads in Plains
IRC-38 – 1988	Guidelines for Design of Horizontal Curves for Highways & Design Tables
IRC:SP:23-1993	Guidelines for Vertical Curves for Highways
IRC:92-2017	Guidelines for Design of Interchanges in Urban Areas
IRC:69-1977	Space Standards for Roads in Urban areas

IRC:42-2014	Guidelines of Road Drainage
IRC: SP:50-2013	Manual for Grade Separators and Elevated Structures
IRC: SP:50-2013	Guidelines on Urban Drainage
IRC-58 – 2015	Design Of Rigid Pavements
IRC-37-2018	Design of Flexible Pavements
IRC: SP-41-1994	Guidelines for the Design of At-Grade Intersections in Rural & Urban Areas
IRC-67-2012	Code of Practice for Road Signs
IRC-35-2015	Code of Practice for Road Markings
IRC-32-1969	Standard for Vertical and horizontal Clearances of Overhead Electric Power and telecommunication Lines as Related to Roads
IRC-54– 1974	Lateral and vertical clearances at Underpasses for Vehicular Traffic.
IRC: SP 91-2010	Guidelines for Road Tunnels
IRC: SP 84-2019 and SP 87-2019	Manual of Specifications and Standards for Four/Six Laning of Highways



Detail Project report for Construction of 11.85km long twin tube, 2 lanes + 1 emergency lane each highway tunnel for connecting Thane on Eastern Express Highway to Borivali on Western Express Highway in the state of Maharashtra



## The Land acquisition Assessment

Alignment passes through below the SGNP forest & ESZ area details of the land acquisition is indicated below

<b>Item wise Breakup of the required Forest and Non Forest Land for TWIN TUBE, 2 SIDES EACH, TUNNEL by MMRDA</b>											
<b>Item of work / Purpose:</b> Proposed TWIN TUBE, 2 SIDES EACH, TUNNEL from Thane to Borivali in Mumbai Suburban District. <b>User Agency - MMRDA</b>											
Name of Village	Forest Land						Non-Forest Land Required				
	S.No.	Length	Width	Area (m <sup>2</sup> )	Area (Ha.)	Status of Land	S.No.	Length	Width	Area (m <sup>2</sup> )	Area (Ha.)
<b>(UNDER SANJAY GANDHI NATIONAL PARK)</b>											
MAGATHANE	34 B	3878.2340	40.6812	157771.0730	15.7771	UNCLASSIFIED FOREST					
<b>(UNDER ESZ OF SANJAY GANDHI NATIONAL PARK)</b>											
MAGATHANE							26	190.00	37.9945	7218.9500	0.7219
							27	43.00	49.1377	2112.9220	0.2113
							28	129.00	42.7108	5509.6940	0.5510
							29	9.00	39.3548	354.1930	0.0354
							40	142.00	62.9831	8943.5960	0.8944
							43	101.00	31.1239	3143.5170	0.3144
							50	460.00	26.8809	12365.1980	1.2365
							56	44.00	3.0991	136.3590	0.0136
<b>SUB TOTAL</b>				<b>157771.0730</b>	<b>15.7771</b>					<b>39784.4290</b>	<b>3.9784</b>
<b>Total Land (Forest + Non Forest)</b>							<b>19.7556</b>				
<b>(UNDER SANJAY GANDHI NATIONAL PARK)</b>											
CHENE	101 PT	260.7100	52.1308	13591.0319	1.3591	FINALLY ACQUIRED FOREST					
<b>SUB TOTAL</b>				<b>13591.0319</b>	<b>1.3591</b>					<b>0.0000</b>	<b>0.0000</b>
<b>Total Land (Forest + Non Forest)</b>							<b>1.3591</b>				



Detail Project report for Construction of 11.85km long twin tube, 2 lanes + 1 emergency lane each highway tunnel for connecting Thane on Eastern Express Highway to Borivali on Western Express Highway in the state of Maharashtra



**(UNDER ESZ OF SANJAY GANDHI NATIONAL PARK)**

YEUR	20 PT	15.000 0	39.540 9	593.1130	0.0593	FINALLY ACQUIRED FOREST	7/3	50.00	54.7227	2736.1370	0.2736
							7/4	10.00	4.2402	42.4020	0.0042
							7/2	130.00	70.3689	9147.9590	0.9148
							7/9	100.00	18.2964	1829.6370	0.1830
							47/1	29.00	29.3026	849.7760	0.0850
							47/3	258.00	46.9336	12108.8800	1.2109
							47/2	105.00	20.2979	2131.2810	0.2131
							6/5	57.00	14.6700	836.1900	0.0836
							NA2	90.00	15.4522	1390.7000	0.1391
							NA	100.00	73.9394	7393.9360	0.7394
							NA1	19.00	41.2027	782.8510	0.0783
							ROAD	8.00	71.8934	575.1470	0.0575
							20	80.00	69.3469	5547.7540	0.5548
							24/2	89.00	35.5880	3167.3350	0.3167



Detail Project report for Construction of 11.85km long twin tube, 2 lanes + 1 emergency lane each highway tunnel for connecting Thane on Eastern Express Highway to Borivali on Western Express Highway in the state of Maharashtra



<b>Item wise Breakup of the required Forest and Non Forest Land for TWIN TUBE, 2 SIDES EACH, TUNNEL by MMRDA</b>											
<b>Item of work / Purpose :</b> Proposed TWIN TUBE, 2 SIDES EACH, TUNNEL from Thane to Borivali in Mumbai Suburban District.											
User Agency - MMRDA											
Name of Village	Forest Land						Non-Forest Land Required				
	S.No.	Length	Width	Area (m <sup>2</sup> )	Area (Ha.)	Status of Land	S.No.	Length	Width	Area (m <sup>2</sup> )	Area (Ha.)
							24-Jan	97	20.5988	1998.083	0.1998
							24-Mar	47	28.6959	1348.708	0.1349
							24-Apr	123	16.0577	1975.098	0.1975
							23	204	60.374	12316.29	1.2316
							22-May	14	2.0376	28.527	0.0029
							22-Apr	81	73.6265	5963.75	0.5964
							22-Feb	48	10.603	508.943	0.0509
							22-Mar	107	66.2537	7089.147	0.7089
<b>(UNDER SANJAY GANDHI NATIONAL PARK)</b>											
<b>YEUR</b>	106 (37)	2331.045	41.017	95612.416	9.5612	RESERVE FOREST					
	106 (37)	872.329	41.0559	35814.243	3.5814	RESERVE FOREST					
<b>SUB TOTAL</b>				<b>132019.77</b>	<b>13.202</b>					<b>79768.531</b>	<b>7.9769</b>
<b>Total Land (Forest + Non Forest)</b>							<b>21.1788</b>				

<b>(UNDER SANJAY GANDHI NATIONAL PARK)</b>											
BORIWADE	80	391.348	41.0071	16048.061	1.6048	RESERVE FOREST					
<b>SUB TOTAL</b>				<b>16048.061</b>	<b>1.6048</b>					<b>0</b>	<b>0</b>
<b>Total Land (Forest + Non Forest)</b>								<b>1.6048</b>			
<b>(UNDER ESZ OF SANJAY GANDHI NATIONAL PARK)</b>											
MANPADA							59A/2	405	8.7638	3549.341	0.3549
							59A/3	9	5.4763	49.287	0.0049
							59A/4	10	2.1943	21.943	0.0022
<b>(UNDER SANJAY GANDHI NATIONAL PARK)</b>											
MANPADA	59A/1 PT	409.254	37.9654	15537.511	1.5538	RESERVE FOREST					
<b>SUB TOTAL</b>				<b>15537.511</b>	<b>1.5538</b>					<b>3620.571</b>	<b>0.3621</b>
<b>Total Land (Forest + Non Forest)</b>								<b>1.9158</b>			
<b>(UNDER SANJAY GANDHI NATIONAL PARK)</b>											
MAJIWADA	420	32.83	21.5721	708.212	0.0708	RESERVE FOREST					
<b>(UNDER ESZ OF SANJAY GANDHI NATIONAL PARK)</b>											
MAJIWADA							314	265	18.0596	4785.797	0.4786
							319	97	17.9134	1737.595	0.1738

Item wise Breakup of the required Forest and Non Forest Land for TWIN TUBE, 2 SIDES EACH, TUNNEL by MMRDA												
Item of work / Purpose : Proposed TWIN TUBE, 2 SIDES EACH, TUNNEL from Thane to Borivali in Mumbai Suburban District.												
User Agency - MMRDA												
Name of Village	Forest Land						Non-Forest Land Required					
	S.No.	Length	Width	Area (m <sup>2</sup> )	Area (Ha.)	Status of Land	S.No.	Length	Width	Area (m <sup>2</sup> )	Area (Ha.)	
							321	340	57.1562	19433.124	1.9433	
							312	320	28.2872	9051.901	0.9052	
<b>SUB TOTAL</b>				<b>708.212</b>	<b>0.0708</b>					<b>35008.417</b>	<b>3.5008</b>	
<b>Total Land (Forest + Non Forest)</b>							<b>3.5717</b>					
<b>TOTAL LAND UNDER SGNP (Forest &amp; Non Forest)</b>												
<b>TOTAL LAND (Forest) UNDER SGNP</b>		----->	<b>335082.55</b>	<b>33.5083</b>	<b>TOTAL LAND (Non Forest) UNDER SGNP</b>		----->	<b>0</b>	<b>0</b>			
<b>TOTAL LAND UNDER ESZ OF SGNP (Forest &amp; Non Forest)</b>												
<b>TOTAL LAND (Forest) UNDER ESZ OF SGNP</b>		----->	<b>593.11</b>	<b>0.0593</b>	<b>TOTAL LAND (Non Forest) UNDER ESZ OF SGNP</b>		----->	<b>158181.95</b>	<b>15.8182</b>			

TOTAL LAND UNDER SGNP ESZ & SGNP (Forest & Non Forest)															
TOTAL LAND (Forest) UNDER SGNP & SGNP ESZ		----- -->		335675.66	33.5676	TOTAL LAND (Non Forest) UNDER SGNP & SGNP ESZ		----- -->		158181.95	15.8182				
Area (m <sup>2</sup> )		Area (Ha.)		Area (m <sup>2</sup> )		Area (Ha.)		TOTAL FOREST & NON FOREST SGNP & ESZ OF SGNP		Area (m <sup>2</sup> )		Area (Ha.)			
TOTAL FOREST & NON FOREST SGNP		TOTAL FOREST & NON FOREST LAND IN THE ESZ OF SGNP		335082.6		33.51		158775.1		15.88		493857.61		49.39	

#### Some key point of the land acquisition

1. The land width required for developing arterial road is 30-60m.
2. The authority has approved a land width of 41.5 m in the SGNP area
3. Approximately 500 m<sup>2</sup> on either side of portal is required for operations services parking and emergency use
4. MMRDA needs to identify the dumping zone prior to start of the work.
5. Casting yard for TBM works of the both tunnels approx. area of 12 Acre will be required

# Utility Mapping

A detailed Survey of existing utilities has been carried out. Details of the same are enclosed in the report.

## Thane Side Utility Mapping

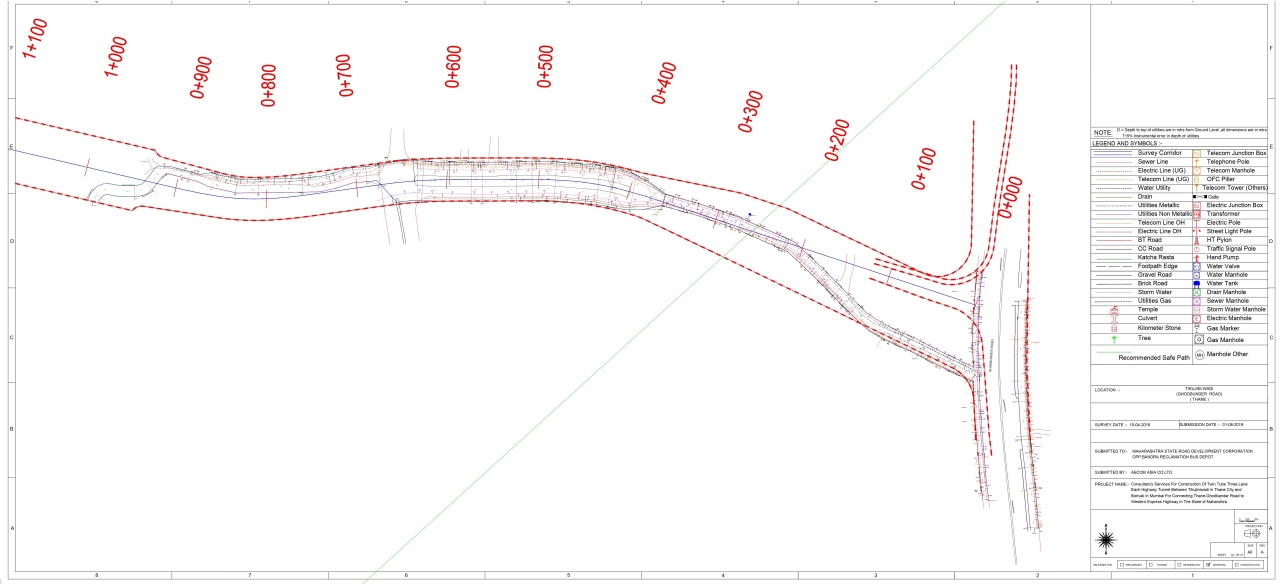

## Borivali Side Utility Mapping

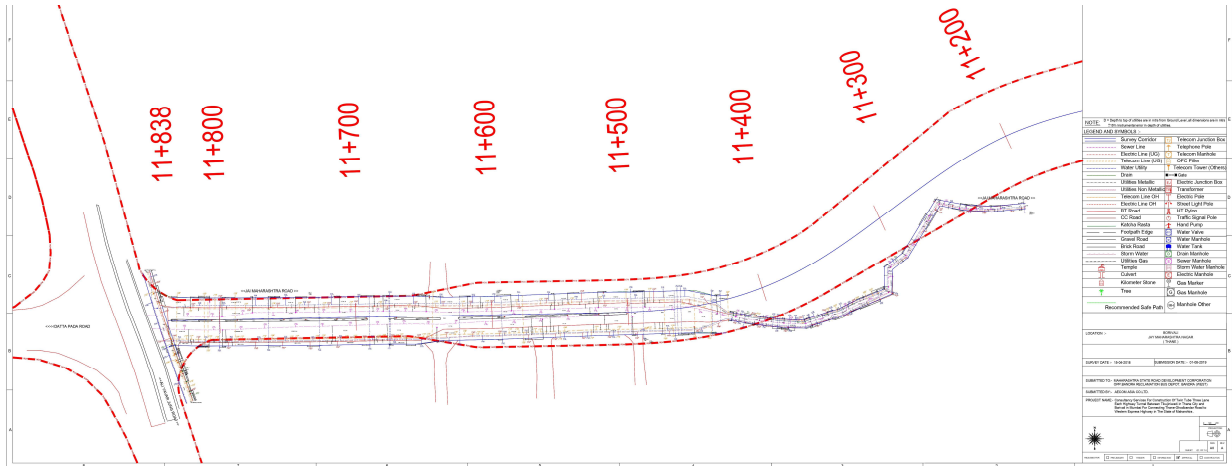

## Geometric Design Standards

The safety of motorists, pedestrians, efficiency, economy, and comfort of vehicle operation are governed by the adequacy of geometric standards. The geometric design is carried out categorizing the project road as Arterial link as it connects two major highways viz. Western Express Highway and Thane Ghodbandar Roads passing through the cities of Mumbai and Thane respectively. Based on IRC Codes the following standards have been recommended.

Mainline Alignment		
Item	Parameter	Proposed
1	Roadway Classification	Arterial
2	Design Speed (kmph)	80-50*
3	Carriageway	
	- 2 x 11.00 m (Approach)	3+3 Lanes
	- 2 x 7.00 m with 2.5 m emergency lane (Twin Tunnel)	2 (up)+2 (down) Lanes along with 2.5 m Emergency Lane in both the tunnels
	Lane Width (m)	3.50
4	Minimum Median Width on approach road (m)	1.0 m
5	Min. Footpath Width (m)	1.5m
6	Minimum Stopping Sight Distance (m)	120 - 60
7	Gradient	
	Maximum (%)	4.0
	Minimum (%)	0.3
8	Horizontal Control – Minimum Radius (m)	250
9	Maximum Super elevation (%)	4

### Notes:

Geometry Design criteria for Grade separators/ Intersection shall be as per the design layout drawings

\*Design speed reduced to 50 KMPH at some locations due to roadside developments and other constraint

### Cross-Section Elements

The cross-sections of Tunnel and Approach Roads under consideration are designed based on the lanes suggested by traffic demand forecast for next 20 years and the limitations imposed by available width. The traffic demand forecast is given in relevant section of this report. The details of proposed cross-sectional elements for Tunnel and Approach Roads under consideration:

**Tunnel:**

Carriageway Width	-	2 x 9.5 m - (2x 3.5+2.5 m)
Median width	-	Varying from 14.5 m to 22.0 m
Drain (below footpath)	-	0.6 m

**Approach Road:**

Carriageway Width	-	2 x 10.5 m (2 x 3.5 m)
Edge Strip (Kerb Shyness)	-	2 x 0.25 m
Median width	-	1.0
Drain	-	2 x 1.0

Service Road (Left and Right)

Carriageway Width	-	2 x 5.5/7.5 m
Footpath and Drain	-	2 x 1.5 m

**Horizontal Alignment**

The horizontal alignment, generally, designed to follow the existing roads and DP roads considering their DP widths (RoWs) in the approach portion on both sides of the tunnel up to the portals and the designated corridor which has been agreed with Forest dept. for the tunnel proper as this stretch being inside the Sanjay Gandhi National Park. The tunnel is proposed to take it underground inside the National Park from Borivali side boundary to Thane side boundary and tunnel portals are proposed outside the National Park. Therefore, all geometric elements have been designed to restrict the roadway/tunnelway within the designated corridor that meets the approved design parameters The horizontal alignment is designed based on the design criteria specified above.

The horizontal circular curves with spiral transitions/curves are attached on either side to attain the super elevation with respect to the centerline of the dual three lane carriageway. Design speed, super elevation and coefficient of side friction were taken as per the codes while designing circular curves.

Based on standards discussed in previous sections, geometric design of project road is carried out by using 'CIVIL 3D ' design software. Based on intersection point coordinates and basic curve data, the software generates complete alignment designs and drawings on the topographical survey base plans. The details generated include centerline, road edge, cycle track, footpath edge, chainage, horizontal curve data, super elevation data, etc. The vertical alignment is then designed in a similar manner using the software.

Road Plans including for the tunnel portion's are prepared showing the designed elements such as centerline, median, carriageway, footpaths, structure locations, at-grade intersections and existing ground features.

### Vertical Alignment

The vertical alignment is designed based on the design criteria given in the previous paras. The ground profile and the finished road profile have been developed along the alignment. Generally the vertical profile is dictated by obligatory levels of structures such as Overpasses, Intersections, and vertical Clearances, horizontal and vertical cover for tunnel portal and tunnel, and access to adjoining properties.

The Approach Cut at the Borivali End is expected to be about 390 m. long. Maximum depth of cut would be about 20 m. at the location where excavated portal of the tunnel is expected to be formed.

The Approach cut at the Thane End is expected to be about 620 m long, and maximum. depth of cut would be about 25 m at the location where the excavated portal of the tunnel is expected to be placed.

### 5.4 Salient Features of Alignment

Total Length including approaches	-	11.850 km
Length of the Tunnel (Between the Portals)	Left Tube	- 10.250 km
	Right Tube	- 10.250 km
Thane Side Approach	-	1.0 km
Borivali Side Approach	-	0.6 Km
Intersections	-	4 including end points with WEH and Ghodbundar Road)
Under passes	-	2
Service Roads on both sides	-	Borivali side-390 m and Thane side – 620 m
Grade Separators	-	3
		Thane Side – 2
		Borvali Side - 1

## 5.5 Toll Plaza



**The open road toll plaza method is proposed for toll collection.** Open road tolling (ORT), also called **all-electronic tolling, cashless tolling, or free-flow tolling**, is the collection of tolls on toll roads without the use of toll booths. An electronic toll collection system is usually used instead. The major advantage to ORT is that users are able to drive through the toll plaza at highway speeds without having to slow down to pay the toll. In some installations, ORT may also reduce congestion at the plazas by allowing more vehicles per hour/per lane.

The disadvantage to ORT is that it relies on the honor system to the extent that without the presence of toll booths there is typically no physical means of preventing drivers who have no intention of paying the toll from accessing the road. Toll operators refer to such toll evasion as "leakage." To deter such behavior, toll operators can employ tools such as high-definition cameras to identify violators, and leakage can be offset in part or whole by fees and fines collected against offenders. However, in many cases such enforcement is relatively limited (for example, targeting only commercial vehicles and other such flagrant and/or repeat offenders). Some toll operators prefer to simply write off leakage as an expense, especially if the costs associated with collection efforts are expected to exceed the additional tolls, fees and/or fines that will likely be collected, or alternatively allow vehicles that are privately operated and/or below a specified size and/or weight to access the toll road free of charge.

### Transition

A transition of 1 in 20 to 1 in 10 will be required from six-lane to the widened width at Toll Plaza on either side. Due to ROW and gradient issues, the transition is limited to 1 in 8.

### Alignment at glance



Proposed Junction Details :- Thane side

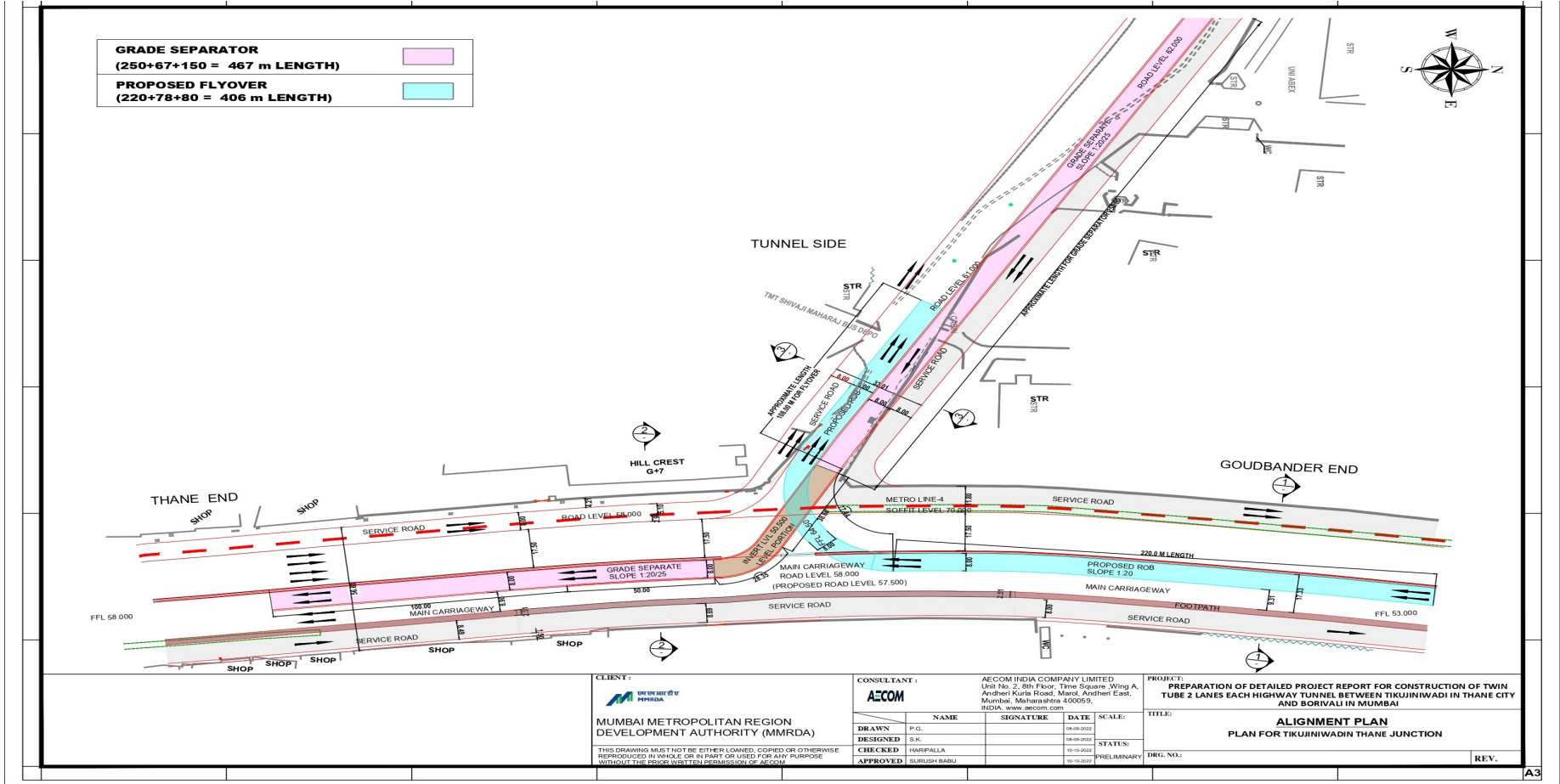

**Borivali Side**

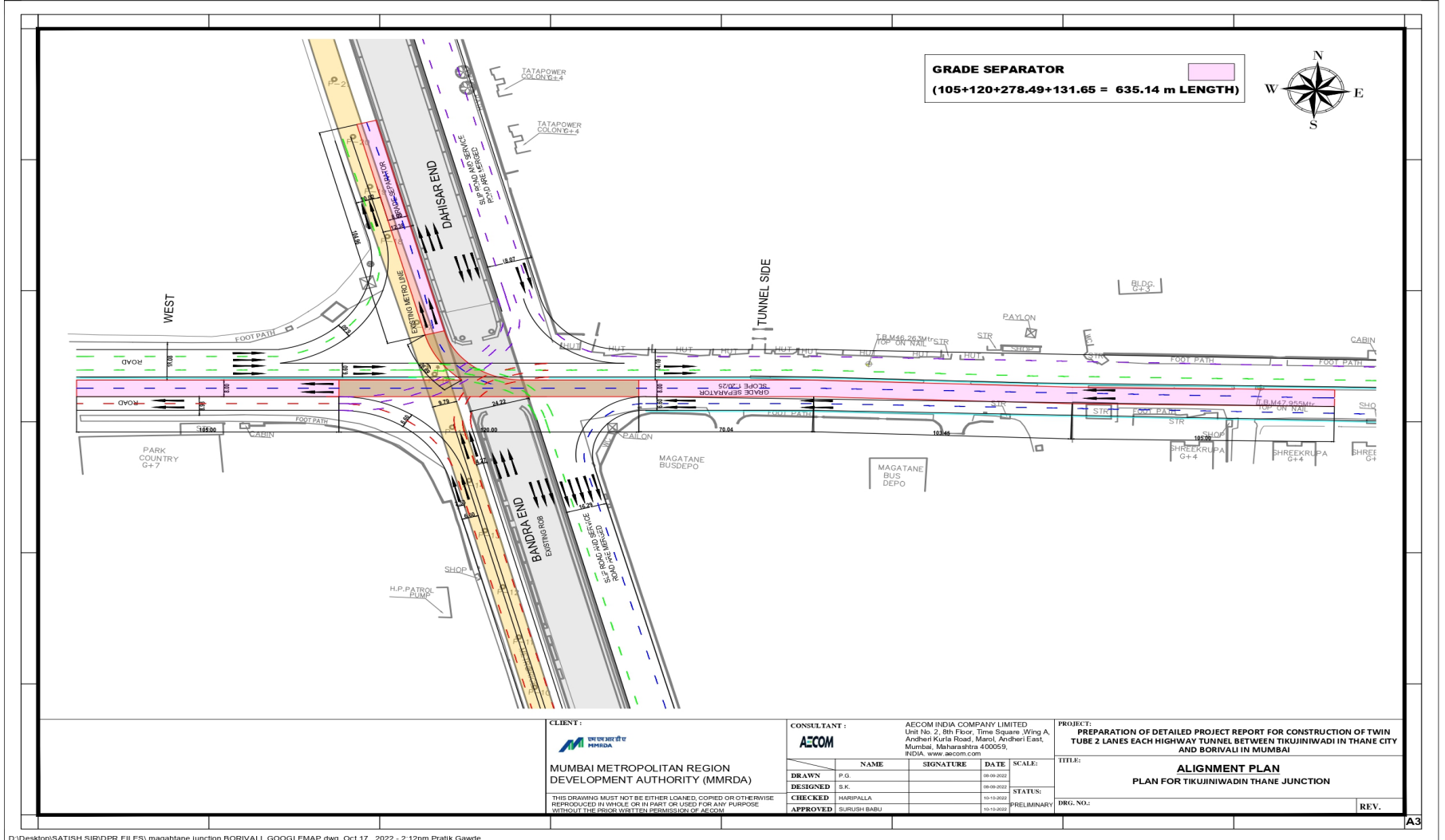

D:\Desktop\SATISH SIR\DRP FILES\magahtane junction BORIVALI GOOGLEMAP.dwg Oct 17, 2022 - 2:12pm Pratik Gawde

**Typical Cross section recommended in IRC 84**

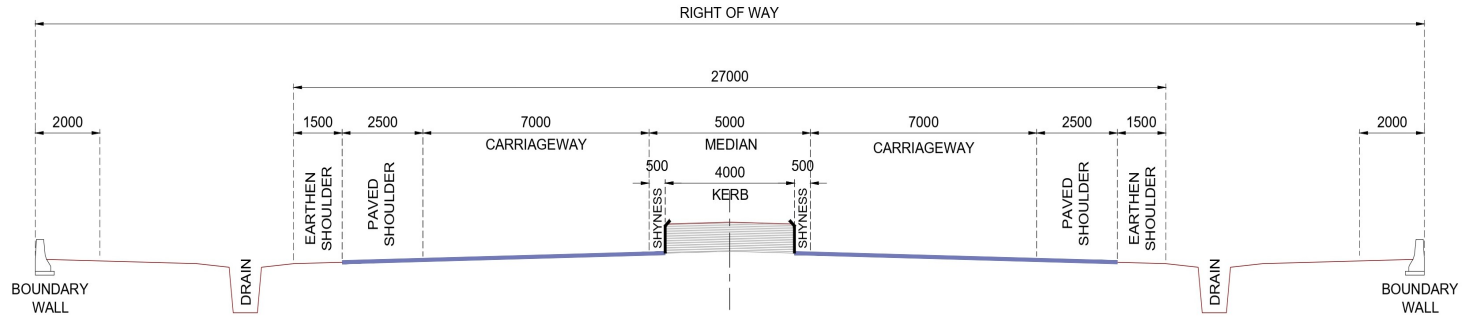

**TYPICAL CROSS SECTION**  
(4 LANE HIGHWAY WITHOUT SERVICE ROAD AND WITH RAISED MEDIAN)

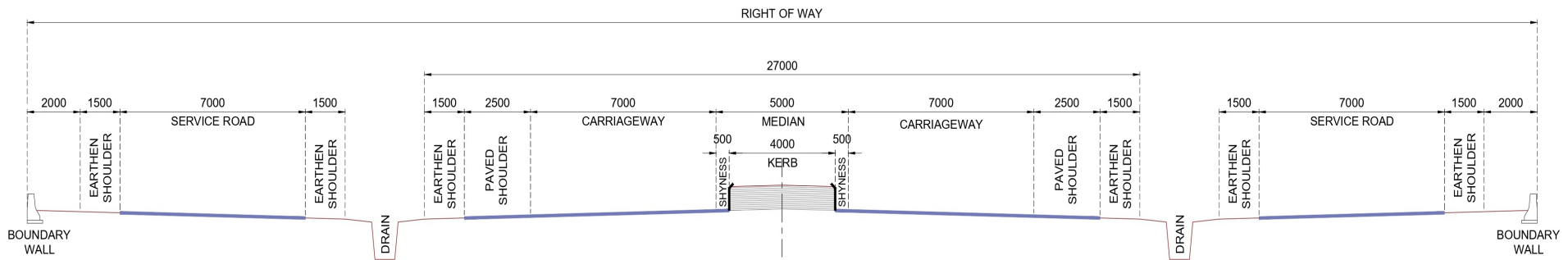

**TYPICAL CROSS SECTION**  
(4 LANE HIGHWAY WITH SERVICE ROAD AND WITH RAISED MEDIAN)

## 5.6 Geotechnical Investigation Report

Based on our recommendation for Tunnel Alignment for Thane – Borivali Highway Tunnel passing through Sanjay Gandhi National Park, Engineering Survey and Geotechnical Investigations have been carried out with respect to physical infrastructure, level of service to the road users, accessibility, constructability, environmental issues etc. and our review remarks, observations, etc. are presented in the following sections.

### Topographical Survey

The scope, objective, methodology and finding of Topographical Survey carried out for Thane – Borivali Highway Tunnel have been explained in this section.

#### 1. Scope and Objective

To establish the centre line of the Tunnel Alignment at Grade and for preparation of Design Base Report, Alignment Design (Vertical and Horizontal Alignment), the following aspects are considered to maximise accuracy during Topographical Survey.

- Availability of Overburden
- Availability of land for Portal location;
- Number of Tree affected;
- Number of Structure affected;
- Demarcation of Forest Boundary;
- Accessibility of Approach Road;
- Availability of Land for Construction Yard.

Further this section is broadly divided into 2 parts:

- **Part 1** - focuses on topographical survey carried out outside SGNP with Total Station;
- **Part 2** - focuses on topographical survey carried out inside SGNP with Remote Sensing Technology.

### Topographical Survey outside SGNP

#### 1. Survey Location

Topographical Survey was carried out using Total Station on Western and Eastern Side outside SGNP to identify the profile of existing ground, identify the exact Boundary of National Park as per coordinate available from Notification, Availability of Overburden for Tunnel Portals on both the sides. On western side survey was conducted from Magathane Junction on Western Express Highway along the DP Road till Trimurthy Nagar Slum from where our identified Portal Location on the western Side till the forest Boundary with buffer of 50m along the alignment on both the side. On the eastern side, Survey was commenced from Mulla Bagh Junction on Godbhunder Road Thane passing through Neelkanth woods along Thane – Borivali

Highway Alignment till Forest Boundary near Nisarg Garden of Thane municipal Corporation with the Buffer Zone of 50m on both the side of the alignment. Topographical Survey inside SGNP was avoided as SGNP has a dense forest which would have affected visibility and increased the time period and effect productivity.

## 2. Methodology

For the Completion of Toposurvey and finalization of Tunnel Centre Line following methodology is adopted:

- a. Reconnaissance Survey
- b. Establishment of Horizontal and Vertical Control Points
- c. Topography Survey
- d. Alignment Survey
- e. General Topography

### a) Reconnaissance Survey

Prior to initiating a Topography Survey, a thorough search and recovery of existing horizontal and vertical control monuments in the immediate area of the project is required. Also, a field reconnaissance will be required before final control net planning is accomplished, and field work is begun. Recovered control monuments must be evaluated before being used as a basis for new control surveys. All recovered points should be fully described in the survey notes. In this Regard Team of Sr. Surveyor, Project Engineer and Project Manager had a visit with client and identified the Nature of Terrain, Benchmark Location, Easiest & shortest way for bench-mark transfer, approach roads for site & Suitable Locations of Ground control points & secondary control points.

### b) Establishment of Horizontal and Vertical Control Points

The Bench-Mark situated on Kasturba cross road no.2 municipal school BM no. 169 R/N. RL=40.552 m w.r.t. Town Hall Datum had been used as reference Bench Mark and further converted to M.S.L by subtracting 24.46 m, So the RL of BM = 16.092m for Western Side. For Eastern Side BM no. 4 of Thane Municipal Corporation near overhead water tank next to Jail Lake Thane West of RL 6.310 m w.r.t. M.S.L. had been used. These Bench-Marks have been used to transfer to Project area along the road by running a double tertiary level line established on control points & permanent structures, which act as temporary bench mark for vertical control & also we transferred the same on Temporary Benchmark station near the Site area as given below.

Borivali side			
	Easting	Northing	Level
<b>Temporary Bench Mark 1</b>	275948.225	2126710.72	23.451

<b>Temporary Bench</b>	275620.983	2126704.997	21.423
<b>Mark 2</b>			
<b>Temporary Bench</b>	276236.128	2126877.697	27.445
<b>Mark 3</b>			
<b>Temporary Bench</b>	277449.201	21267057.34	33.656
<b>Mark 4</b>			
<b>Thane Side</b>			
<b>Temporary Bench</b>	287186.756	2128569.335	33.786
<b>Mark 1</b>			
<b>Temporary Bench</b>	287007.303	2128720.038	35.428
<b>Mark 2</b>			
<b>Temporary Bench</b>	286821.173	2128796.891	33.645
<b>Mark 3</b>			
<b>Temporary Bench</b>	286561.799	2128817.091	38.914
<b>Mark 4</b>			
<b>Temporary Bench</b>	286274.842	2128837.612	48.488
<b>Mark 5</b>			

### c) Topo Survey

The purpose of a topography survey is to gather survey data about the natural and man-made features of the land, as well as its elevations. From this information a Three- dimensional map is prepared. The topography map was generated in the office after collecting the field data. The process for generating the Topographical Map is follows: -

1. Establishing horizontal and vertical control that will serve as the framework of the survey.
2. Determining enough horizontal location and elevation (usually called side shots) of ground points to provide enough data for plotting when the map is prepared.
3. Locating natural and man-made features that may be required by the purpose of the survey.

4. Computing distances, angles, and elevations
5. Drawing the topographic map Topographic surveys are commonly identified with horizontal and/or vertical control of third and lower order accuracies. Accordingly, we had completed the topography survey boundary.

#### **d) Alignment Survey**

Alignment Survey has been carried out for fixed alignment location and topographical survey prepared around surrounding right of way (ROW). Topographical surveys make it possible to measure the steepness of slopes as well as details of terrain.

Contour survey has been carried out by observing spot levels at 10 m X 10 m. Grid, and/or as per the client's specification. They are plotted on the drawings and the contours are drawn using the Auto CIVIL or Auto Plotter Software. Contours are interpolated at 0.5m intervals and/or as specified by the clients. Generally, additional levels are taken to show the exact profile of the land.

#### **e) Data Collection**

The data collection work was conducted with the use of Total Station. Boundary Details, Elevations within the plot, outside the plot, Road details for the road around the plot, Utility details in and around the plot, Field boundary & other Important Topographic features are collected. The data was collected in various formats and produced in specified / derived formats to the satisfaction of Client.

#### **f) Findings of Topography survey (Total Station)**

Topography survey outside SGNP gave a brief idea about the Existing Ground Level on the approach Roads and the Tunnel Portals on Both the side viz. Eastern and western.

On the Western Side a uniform Slope was observed along the existing DP Road alignment till Trimurty Road. 30 m before Forest Boundary we got a RL of 25.884 m.

On the Eastern Side a gradual steep slope is observed till Neelkanth Woods Circle and a gentler slope till mulla bagh Junction.

### **Topographical Survey inside SGNP**

#### **1. General**

As a part of this project Bhugol GIS Pvt.Ltd was consulted by AECOM, to undertake project for "Contour Generation for a surface area above the proposed tunnel of Thane – Borivali Highway" and perform the following tasks. The project is to generate contours at 10-meter vertical intervals using satellite data analysis for an area of 1.00 Km buffer around the proposed Thane – Borivali Highway Tunnel passing through Sanjay Gandhi National Park (SGNP).

As a part of this project, elevation levels at locations in and around the SGNP surveyed earlier were using Differential GPS (DGPS) and Survey of India Toposheet Benchmark locations were used along with Cartosat 2.5m stereo images. Using the collected elevation data, Survey of India Toposheet and Satellite data the Digital elevation model (DEM) was generated for this area. Further as a part of the project, contours were

extracted using GIS analysis for an area of 1.00 Km buffer around the proposed Thane – Borivali Highway Tunnel alignment.

## 2 Methodology for DEM

### Project Site description

Sanjay Gandhi National Park (SGNP), previously identified as Borivali National Park, is a large protected area in the northern part of Mumbai city (preferably called Mumbai Suburban district) and on western part of Thane City in Maharashtra State in India. It encompasses an area of 104 Km<sup>2</sup> (40 sq. mi) and is surrounded on three sides by India's most populous cities. It is notable as one of the major national parks existing within a metropolis limit and is one of the most visited parks in the world.

The park occupies most of the northern suburbs of Mumbai. To the west lie the suburbs of Goregaon, Malad, Kandivali, Borivali and Dahisar. To the east lie the suburbs of Bhandup, Mulund and City of Thane. To the south lie the Aarey Milk Colony and the university campus of IIT Bombay. The northern reaches of this forest lie in Thane city. The park and these areas surrounding it, except Thane city are all part of Mumbai.

The terrain in this region is hilly with elevations between 30.00 m (98 ft.) and 480.00 m (1,570 ft.). The park encompasses two lakes, Vihar Lake and Tulsi Lake, which meet part of the city's water requirements. Further, The Park is said to be the lungs of the city as it purifies much of the air pollution of the city.

### Data used

There are two Cartosat-1 scenes which cover the Sanjay Gandhi National Park (SGNP) area.

These data sets are provided in Orthokit GeoTiff format and referenced to the WGS84 ellipsoid and datum. Cartosat-1 carries two high-resolution imaging cameras: the afterward looking camera (Aft) and the foreword looking camera (Fore), both the cameras are able to collect panchromatic images with a spatial resolution of 2.5 m on the ground. Thus, each set of data is composed of two images namely band A and band F images. Soft-Photogrammetric Suit has been used to generate DEM from Cartosat-1 stereo data.

### Steps involved in the process

The process of DEM generation in soft photogrammetry is carried by creating a block project file and defining the geometric model as RPC model. Cartosat-1 stereo scenes with Rational Polynomial Coefficient (RPC) within Rational Function (RF) sensor model is used in creating a block file. The Rational Polynomial Coefficient (RPC) file is used to relate the image. The block project is assigned the horizontal and vertical coordinates with UTM projection and WGS 84 datum. The stereo pair images band A and band F are added to the frame.

RPC (Rational Polynomial Coefficients) files contain rational function polynomial coefficients that are generated by the data provider (e.g. NRSC for cartosat-1 data) based on the position of the satellite at the time of image capture. Cartosat-1 RPC files (banda\_rpc.txt and bandf\_rpc.txt) are encrypted metadata files. Hence, it is not readable.

The software allows selecting a matching point in one image, finding its conjugate point in the other (stereo) image. Once the tie points are generated in the overlapping area additional surveyed ground points are added to the images. The X, Y, and Z values for CGP points are provided. The triangulation is done after

adding GCPs and tie points to check the accuracy for GCPs and tie points. Then the resultant data is used to generate the DEM.

### **Digital Elevation Model (DEM )extraction**

The verified data is used with the output cell size 7m considering the Ground Sampling Distance (GSD) of the original stereo pair is 2.5 m. with which the DEM is extracted.

A digital elevation model represents the elevation or attributes value of each grid in a raster format. DEM is normally generated using spatial interpolation from regularly or irregularly spaced data points. Data sources for the input data include direct measurement on the ground using GPS, stereo air photo or satellite images, digitized contour lines, radar data, LIDAR (light detection and ranging) data etc. The quality of DEM can influence the accuracy of terrain measures such as slope, aspect and relief and in deriving the drainage network. DEMs are quite useful for calculating contours, slope, aspect, hill shading and automatic watershed delineation. The limitations are that large amount of data redundancy in the areas of uniform terrain and cannot handle data of high relief area without changing the grid size. The vector-based TIN model helps to overcome these limitations.

### **Generation of buffer around the proposed Highway tunnel alignment**

The proposed alignment of Thane – Borivali Highway Tunnel provided by AECOM was converted first to GIS understandable format. The buffer of 1.00 Km around the alignment was generated using GIS analysis and generated DEM was also extracted according to buffer of the alignment.

### **Extraction of contour**

Once the DEM was extracted as per the buffer, the extracted DEM was used as an input to extract contours at 10 m interval using GIS analysis.

The most common method for terrain mapping is contouring. Contour lines connect points of equal elevation and the contour interval or vertical resolution is the elevation difference between two adjacent contours. Contour lines are closely spaced in high relief terrain. Contour lines do not intersect one another and do not stop in the middle of the map. Contour lines can be generated from a DEM or TIN. In TIN model, the triangles are divided into smaller triangles and using linear interpolation technique, contour lines are generated. Vertical profiling method helps to show the elevation values along a linear feature such as a road and it can be plotted on a graph. The vertical profile is very useful to estimate the volume of material needed to be removed or to be filled while proposing a road or a canal construction work.

Hill shading simulates how the terrain looks with the interaction between sunlight and the surface. A hill slope facing the sunlight will be bright and a slope opposite to the light will be dark. Hill shading helps to recognize the shape of landform features. The factors that control the visual effect of hill shading are the sun's azimuth angle (ranging from 0° due north to 360° in clockwise direction), sun's altitude (angle of the

incoming light measured above the horizon between 0° and 90°), terrain slope (ranging from 0° and 90°) and aspect.

Perspective views are 3D views where the terrain appears as being viewed with an angle from a height. The parameters that control the appearance of a 3D view are viewing azimuth (direction from the observer to the surface ranging from 0o to 360o in clockwise direction), viewing angle (the angle from the horizon to the altitude of the observer ranging from 0o to 90o), viewing distance (the distance between the viewer and the surface) and z scale (ratio between the vertical scale and horizontal scale additionally known as vertical exaggeration factor). Using perspective view option in GIS packages, one can view the surface in various rotations and navigate through the surface.

Once the contours were extracted, they were compared with the Toposheet and necessary correction was made wherever required to make the final data.

The final generated contours were additionally draped over the google earth data after converting them into .kmz file which is additionally provided as one of the outputs. The indicative final result is presented in the next Figures 5.1 & 5.2

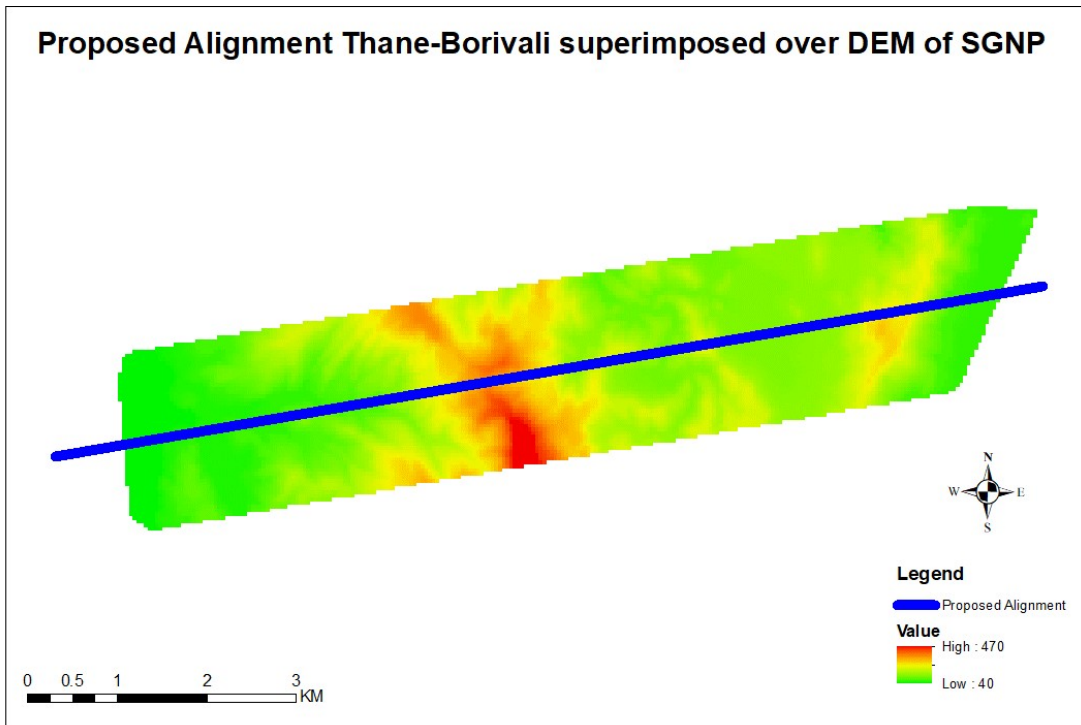
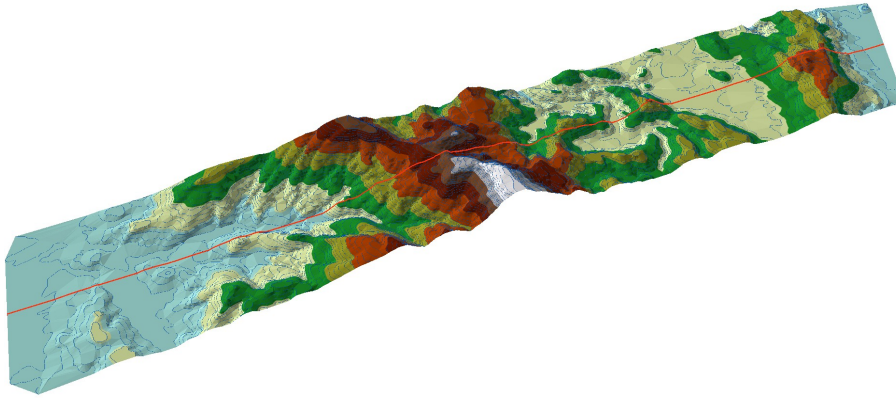

Figure 5.1: Proposed TBHT alignment with DEM inside SGNP



**Figure 5.2: Proposed TBHT alignment with Contours inside SGNP**

## 5.7 Geology and Seismicity

### 1. General Geology of the area

The project area is located approx. between the Latitude 19° 10' to 19°19' and Longitude approx. 72°45' to 73°. The proposed tunnel is approx. 10.2 km long between Thane to Borivali. The coastline of the area trends almost N to S with a number of creeks, prominent among these being Dahanu Creek, Vasai Creek and Thane Creek. The main physical features of the land are the coastal plains and the hilly tracts to the east. Project is situated between Borivali to Thane in Maharashtra. The area is drained by tidal rivers like Ulhas river, Vaitarna river and their tributaries. The rivers run down to the western scarp of the Western ghats into the Arabian Sea. The entire greater Mumbai area is occupied by Deccan Basalt flows and their other acid and basic variants, discharged out during the period of Late Cretaceous to Early Eocene. The basaltic flows are horizontally bedded and are more or less uniform in character over wide areas. Certain intrusive and extrusive mafic types are associated with basalt's and are found in the Mumbai islands and its vicinity. Further, some fossiliferous sediment, mainly of tuffaceous origin and partly of freshwater origin, rich in fauna are also found in Mumbai area. Geomorphologically, Mumbai Island has ridges along its western and eastern sides. The city of Mumbai is built on the central low-lying part of the island. The western ridge comprises stratified ash beds overlain by hard, massive andesitic lava flows, both formations showing gentle tilt towards the west. The stratified ash which display variegated colors and variable textures attain a total thickness of about 45m.

The ash beds are capped by massive lava flows which attain a thickness of about 16 m. The rocks are aphanitic, have a conchoidal fracture and exhibit conspicuous hexagonal columnar jointing. They are exposed on the Malabar, Cumballa, Worli hills and extend on to the Salsette Island. Dark colored fossiliferous shales attaining a thickness of about 2m are exposed at the foot of the Worli hills. Being deposited during a period of quiescence and overlain by a later flow, these beds are known as intertrapean Beds. The central portions of Salsette Island comprise a range of hills trending north-south merging with the tidal swamps towards the east, while towards the west these hills pass into wide plains with a few isolated hillocks. Basalt is a major rock unit constituting the main ridge extending from Ghatkopar, Aarey milk colony to Kanheri, east of Jogeshwari or beyond. At places, there are Ash beds intervening between successive flows, these may be seen in the cuttings of the Western express highway passing through Jogeshwari.

Another interesting geological feature is the occurrence of a vast thickness of volcanic agglomerate near Tulsi lake and Kanheri caves, indicating a possible volcanic focus from which much of the pyroclastic rocks in the Mumbai and Salsette islands may have extruded. Volcanic agglomerate can be observed at Sanjay Gandhi national park and Kanheri caves which is made up of sub angular vesicular bombs and blocks of brown chert, trachyte, volcanic ejecta and small pieces of yellow to reddish brown limonitic matter in a dense dull light grey amorphous material. At places this matrix resembles Bauxite.

A well-marked fault is seen near Antop hill. Sukeshwala (1958) has given evidence for two north-south running faults in Mumbai island, one of the east of western ridge and other running along the western ridges. The faults extend into Salsette island and have maximum throw of 75' and 40' respectively.

The lava flow of Mumbai (Bombay) dips westerly at 50 - 100 to the west of the Panvel Flexure. The occurrence of two lava flows with a thick sequence of intertrappeans has been previously described at Mumbai Island. The lava flows are seen to be mainly of subaqueous character and do not persist at higher levels in the Western Ghats. These lavas appear to have formed after the rifting of the main plateau basalts, along the Indian west coast, and during the thinning and subsidence of the coastal margin while the subcontinent was moving towards northeast (Sethna 1999).

The lavas of the Mumbai area are believed to represent a much younger phase in the eruptive sequence of the Deccan Volcanic Province. It is proposed to classify these lavas as belonging to a separate sub group- the Salsette Subgroup. In the Mumbai Island area, at least seven distinct lava flows have been recognized. The older Sewri flow and the youngest Malabar Hill lava flow are partly subaqueous and partly subarial, indicating that these lavas erupted under shallow water conditions, possibly during a period of subsidence of the region which followed the rifting of the plateau basalt along the west coast margin of the Indian subcontinent. Although the basalts of Mumbai have not been dated, it is believed that the entire Salsette Subgroup was formed at around 62 Ma, thus predating the main phase of Deccan volcanism (Sethna 1999).

The Malabar Hill flow is of particular significance in connection with the proposed project. The flow is underlain by a substantial thickness of weaker lithified tuffaceous ash debris and volcanic breccia. The gently shelving seabed platform to the west of Mumbai comprises a varied sequence of tuffs, volcanic breccias and carbonaceous shales that overly the Malabar Hill lava flow. These younger deposits are of considerable lateral extent, beneath a thin seabed veneer of recent marine sediments and some completely weathered lava surfaces. In consequence, the strata present at the project site comprise the lower remnants of the Malabar Hill flow beneath which lie a considerable thickness of intertrapean rocks

## **2. Seismo-tectonics:**

Based on frequency and intensity of expected earthquakes in different areas, these have been categorised in different seismic zones on the seismic zoning map of India. Higher the zone the seismic hazard risk is more. Mumbai region falls in zone 4 on this seismic zoning map dividing India in to 5 different zones. The designs for tunnel and other structures shall consider the corresponding seismic zone factor.

Figure 5.3: Seismotectonic map of the area.

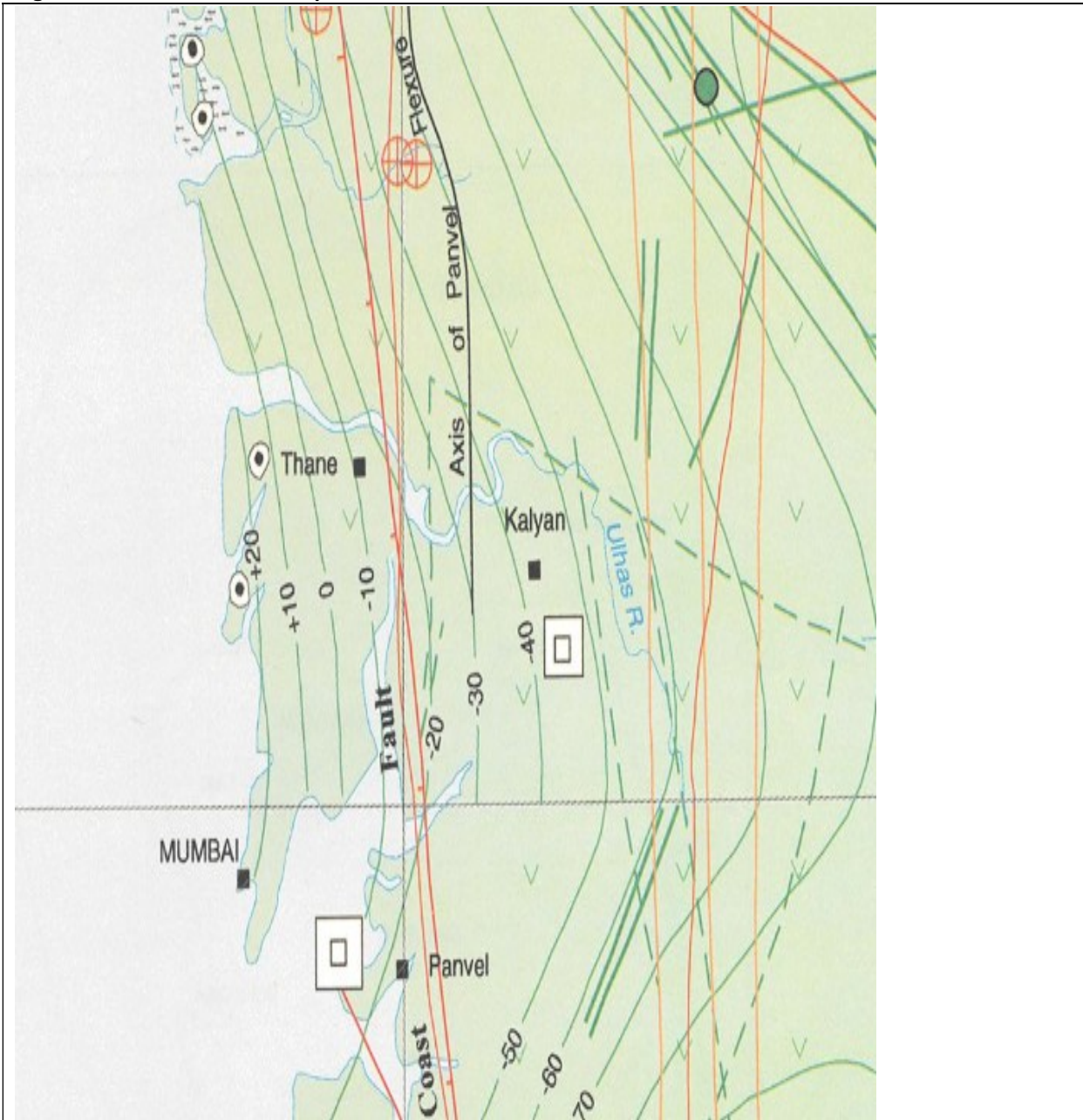

## Legend

### MAGMATISM



- a. Alkaline Plutonic
- b. Mafic Intrusive

### OTHER FEATURES

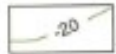

Bouguer Gravity Anomaly conto



Thickness of Deccan Trap in m



Moho depth in km

### STRUCTURAL SYMBOLS



- a. Neotectonic Fault
- b. Fault involving basement at

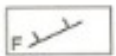

Gravity Fault

### SEISMICITY

DATA PERIOD HISTORIC - 1900		
Magnitude (M)	Not Determined	5.0 - 5.9
Intensity (I Max)	V	VI-VII
Depth (km)		

DATA PERIOD 1901 - 1963		
Magnitude (M <sub>S</sub> )		4.0 - 4.9
Depth (km)		

DATA PERIOD 1964 - 1993		
Magnitude (M <sub>b</sub> )	Not Determined	4.0 - 4.9
Depth (km)		
Not Determined	○	○
0 - 40	●	●

### 3. Geology along the alignment

The alternative alignments for the proposed road tunnel between Borivali to Thane are situated in Sanjay Gandhi National Park region.

The geological model is developed on the basis of surface geological mapping, geophysical survey and core drilling operations.

Geological map is attached with the Annexures. The area comes under the National park known as Sanjay Gandhi National Park of Thane District in Maharashtra which serves as home for many wild animals and varied flora and fauna.

The alignment has been explored by NX size core drilling at 12 locations. These locations were selected on the basis of surface geological mapping. On the basis of geological mapping and drilling data geological cross section has been prepared

A digital elevation model was prepared using high resolution satellite images Flash flood and land slide potential at portals

Western portal of the tunnel is accessible through NH8 and further from Shiv Vallabh Road which will be finally reached to the portal via a proposed approach road. The main rock type comprising the tunnel expected to be Unclassified Basaltic 'Aa' lows up to a length of approximately 7300 m. Geological map along

the alignment has been appended. After 'Aa' flows Agglomerate and Tuffs shall encounter for approximately another 1 km and again 'Aa' flows will encounter till the end of Eastern Portal. Eastern portal is connected to Pokharan Road 1 from a proposed Approach road and then further to NH 3.

A minor fault has been identified at an approximate chainage of 3+800 m with down throw which will encounter the tunnel at approx. Ch. 3+740 to 3+840. Fractured rock mass shall encounter at the vicinity of the fault at the tunnel grade. A river is crossing the alignment at Chainage 6+500 m where wet to dripping ground water conditions may encounter. The minimum and maximum overburden in the tunnel is 32.0 to 385.0 m. Slope wash material of 3-5m could be found throughout the tunnel.

Rock encounter in the tunnel will be hard, massive Basalt of Deccan Traps with uniaxial compressive strength varying from 100-200 MPa. During construction the tunnel will be mostly dry. At western portal weathered rock has been identified during site visit. The major joint is vertical joint set in this area which is closely spaced and can be seen prominently at western portal. Toppling failure may occur as joints are closely spaced to each other. Two photographs of Western portal have been shown below showing the overburden and the joint pattern.

## 5.8 Geotechnical Investigation

### a) Objective

Site investigations or sub-surface explorations are done for obtaining information about subsurface conditions at the site of proposed construction. Site investigation in one form or the other is required for every engineering project. Information about the surface and subsurface features is essential for the design of structures and for planning construction techniques.

As a statutory requirement & to identify required design parameters for safe design, Aecom decided to carry out geotechnical investigation at SGNP (Sanjay Gandhi National Park) Mumbai. Geotechnical investigation work consisted of seventeen boreholes to examine subsurface profile. Depth of boreholes to be drilled was determined using IS: 1892- 1979 section 2.3.2. The lateral extent of exploration and the spacing of boreholes depend mainly on the variation of the strata in horizontal direction. M/s JAY GAJANAN, Thane (W) carried out fieldwork of boreholes from 1st May 2018 to 01st August 2018. Selected rock samples will be submitted for testing in Laboratory & IIT Bombay Laboratory on 04th August 2018. Objective of the site investigation was to obtain the information that may be useful for one or more of the following purposes:

1. To select the type and depth of foundation for a given structure, to access the critical locations along the alignment for tunnel design.
2. To determine the bearing capacity & ground improvement techniques for soil/rock layer.
3. To establish the ground water level & seepage estimation in the tunnel area/section.
4. To select the suitable construction technique.
5. To predict potential foundation problems.
6. To ascertain the suitability of the soil as a construction material.

7. To collect and transport the selected samples of soil and rock in testing laboratory and conduct relevant tests to determine properties.
8. Recommendations for soil-related construction conditions such as site preparation, earthwork construction, excavation slopes, and difficult excavation.

**b) Scope of the Study**

Scope of the Study under this Consultancy Services are basically Pre-contract Works before the actual award. The scope of services included a site reconnaissance, site soil test, borings and soil sampling, laboratory soil testing, engineering evaluation of the field test data, and preparation of this report. Specifically, the scope of our engineering work for this site was to provide the following:

1. Soil nature and origin, including changes resulting from man's activities
2. Depths, thickness, and composition of soil strata that will be appreciably stressed by the intended construction.
3. Depths to encountered groundwater, dense soil strata, and rock that could affect the proposed construction. Collect ground water sample from borehole for chemical analysis. Collect undisturbed soil samples from cohesive soil stratum.
4. Conduct standard penetration tests at an interval of 1.0 to 1.5 meter and collect disturbed soil samples.
5. To prepare a geotechnical investigation report by compiling data collected from field, bore logs, and results of laboratory tests.
6. Recommendations & design parameters for tunnel design, allowable bearing pressures, estimated settlements, footing sizes and depths.

**c) Reconnaissance Survey**

Reconnaissance survey was conducted along the proposed alignment by forest and project representatives on 5-Jan-17 and 6-Jan-17. During the joint survey, locations for geotechnical investigations were identified with the criteria of minimal reversible impact on environment.

Joint team of forest representatives and project representatives as below met at SGNP followed by the survey was conducted.

### SGNP Representatives

- iv. Assistant Conservator of Forest (Protection & Wildlife)
- v. Smt. Priyanka Barge - Range Forest Officer (Tulsi Range)
- vi. Mr. Rajendra Pawar - Range Forest Officer (Krishnagiri Range)
- vii. Mr. Sanjay Waghmode - Range Forest Officer (Yoor Range)

### MSRDC Representatives

- viii. Mr. Shridhar Arlikar, Executive Engineer
- ix. Mr. Aniruddha Borde, Assistant Engineer

### AECOM Representatives

- x. Mr. Atul Kumar,
- xi. Mr. Manas Shirsat,
- xii. Ms. Rashmi Dutta,

Series of photographs tied up with identified Geotech investigation locations on the proposed alignment during the joint survey is presented as below. The photographic log below, represents that the identified locations have enough open space for the installation of drilling machine and no tree felling is required, a



BH 3 location Marked



BH No. 4 Marked



flat surface and not a part of dense forest.



Entry point from tamnipada



Demarkation of the route followed



BH 3 location Marked



BH No. 4 Marked





BH 2 location Identified



BH 5 location Marked



BH 6 location Marked



Natural Drain Near Alignment





BH 7 location Marked



Natural Drain Near Alignment



Kolhapur Style Dam near Alignment



Boulders near Alignment





Highest point Near Yeur



View of Eastern Portal From Yeur top



Exposed Rock Near Alignment



Forest Chowky Near Alignment





Exposed Rock Near Alignment



Exposed Rock Near Alignment



The following Geotechnical investigation programmes was finalised after the finding of reconnaissance survey.

The first stage consisting of drilling of 12 boreholes to get the geological & geo mechanical (Lab Testing) information of the project area, in general drilling of 30 to 110 m in depth. The second investigation stage is in-situ testing such as Permeability & Pressure meter Tests in soil & Rock strata. Field tests such as Electricity Resistivity & Seismic Refraction at the selected locations. Details of the available investigations are presented in Table 5.1 and complete factual data described in the next section.

BH no.	Location	Latitude	Longitude	RL m	Status
1	SGNP	19°13'19.36"N	72°52'18.15"E	25.40	Completed
2	SGNP	19°13'21.97"N	72°52'31.33"E	26.30	Completed
3	SGNP	19°13'25.38"N	72°52'48.19"E	34.23	Completed
4	SGNP	19°13'28.56"N	72°53'4.27"E	35.01	Completed
5	SGNP	19°13'32.15"N	72°53'21.74"E	47.5	Completed
6	SGNP	19°13'34.42"N	72°53'32.65"E	62.4	Completed
7	SGNP	19°13'37.38"N	72°53'47.74"E	71.3	Completed
8	Yeoor	19°14'11.70"N	72°56'40.90"E	114.2	Completed
9	Yeoor	19°14'15.29"N	72°56'55.90"E	123.3	Completed
D	Manpada	19°14'29.33"N	72°58'2.01"E	45.31	Completed
E	Manpada	19°14'29.20"N	72°58'4.99"E	44.48	Completed
F	Manpada	19°14'29.43"N	72°58'7.54"E	42.40	Completed

**Table 5.1: Summary of Boreholes**

### Project Location

The proposed project corridor is from Borivali in Mumbai's Western Suburbs to Thane.

**Figure 5.4: Tunnel Corridor Section for Geotechnical Investigation**

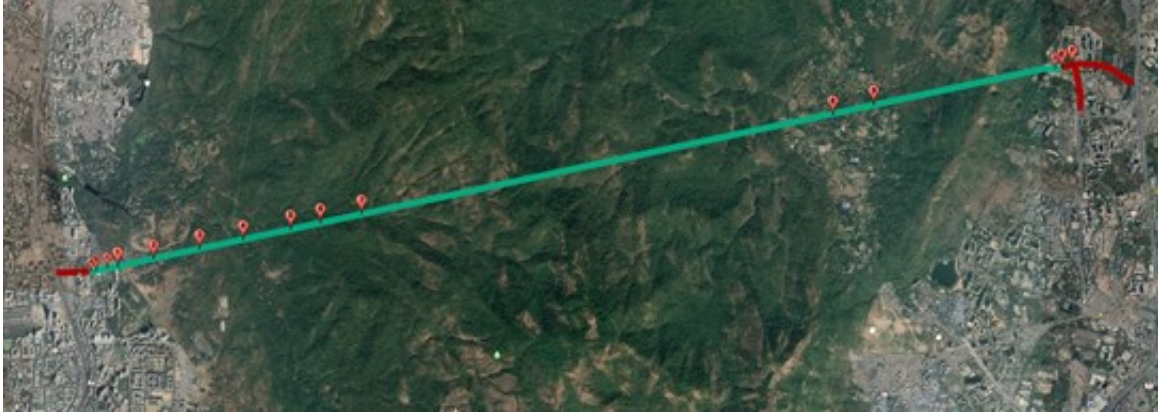

### Planning

A subsurface exploration programme depends upon the type of structure to be built and also upon variability of the strata at proposed site. Sub-surface explorations are generally carried out in three stages.

### Preliminary Exploration

The aim of a preliminary exploration is to determine the depth, thickness, extent, and composition of each soil stratum at the site. The depth of bedrock and the ground water table is also determined. The preliminary explorations are generally in the form of trial pits. Trial pits were not considered for these sub-surface investigations.

### Detail Exploration

The purpose of detail exploration is to determine engineering properties of soil in different strata. It includes an extensive boring programme, sampling and testing. Field test such as vane shear test, SPT, Permeability test to be conducted to determine properties of soil in natural state. The tests for the determination of dynamic properties are also carried out, if required.

### Drilling

Locations of the boreholes are indicated on the attached Boreholes Location Plan. Onsite locations of boreholes were specified by client. The borings were performed to maximum depths of 50 m below the existing ground surface elevations. For drilling rotary type drilling rig was used. Rig was coupled with diesel engine, tripod and all drilling accessories. Drilling rig have tripod with suitable arrangement for driving as well as extracting casing. It was also used for conducting Standard Penetration Test (SPT), and Disturbed or wash Soil Sample (DS).

Initially casing of adequate diameter to suit boring of 100 mm borehole was lowered and boring was commenced. When rock was encountered, size of borehole was changed to Nx (76 mm) diameter. A core barrel and Nx sized bits are used for drilling and recovering rock cores. Recovered rock cores were

numbered serially and preserved in good quality sturdy wooden core boxes. Rock core recovery (CR) and Rock Quality Designation (RQD) were computed for every run of length drilled. Rock samples have been selected for laboratory test based on the probable founding elevation of the proposed structure.

**a) Technical Specifications for Drilling Work**

IS 1892: Code of Practice for Subsurface investigation for foundations.

IS 2131: Method of Standard Penetration Test for Soils

IS 2132: Code of Practice for Thin Walled Tube Sampling of Soils

IS 4078: Code of Practice for Indexing & storage of drill cores.

IS 4464: Code of Practice for Presentation of drilling information and core description in Foundation investigation.

IS 5313: Guide for core drilling observations

IS 5529: Code of Practice for In-situ Permeability Tests

IS 6926: Code of Practice for Diamond Core Drilling for site investigation for river valley projects.

IS 7974: Symbols and Abbreviations for Geological maps, Sections and sub-surface Exploratory Logs.

IS 7422: Symbols and Abbreviations for Geological maps, Sections and sub-surface Exploratory Logs.

**b) Equipment for Drilling**

- Theodolite Levels
- Total station.
- Rotary drilling rigs

**c) Method for Rotary Drilling in Overburden soils**

The machine was set-up at the desire borehole locations. In overburden soil the borehole was drilled by using rotary drilling machine. NX size drilling was undertaken. In loose or very soft soils or whenever there was chance of cave in of soil, temporary casing was used to support the sides of the borehole.

**d) Stabilisation of Bore Hole**

Stabilization of borehole was done by providing suitable temporary steel casing as necessary and which was removed and taken back after completion of borehole as required for preventing caving in of soil/weathered rock.

**e) Storage of Soil Samples**

All the soil Samples (Disturbed and SPT) of one bore hole has been kept in Wooden Box of required size & easy to handle. These Boxes are kept at Site Offices as per directions of the Engineer.

For Soil & Weathered Rock samples, Identification Labels are fixed on the Plastic Pouches, indicating bore hole No., Depth and Visual Soil classification.

#### **f) Rotary Drilling in Rocks**

In the rotary drilling method, the hole was advanced by rotating a drill string consisting of a series of hollow drill rods to the bottom of which is attached either with a cutting bit or a core barrel with a coring bit. Cutting bits shears off chips of the material penetrated and thus is used primarily for penetrating overburden between the level at which samples are required. Coring bit on the other hand was used to cut an annular hole in the rock mass, thereby, creating a cylinder or core of rock that enters the barrel and is retrieved. Thus, the core barrel is primarily being used in rock which under most circumstances shall be cored continuously. As the rods with the bit or barrel are rotated, downward pressure was applied to the drill string to obtain penetration and drilling fluid under pressure was introduced into the bottom of the hole through the hollow drill rods and passages in the bit or barrel.

#### **g) Drilling Run:**

Drill runs not exceeded 1.5 m in length and the core barrel was removed from the drill hole as often as may be required in order to get the best possible core recovery. When recovery was less than 80% for a full-length drill run then the next run was reduced to 1 m. Where a geological feature had been accurately determined, short runs of 30 cm or even smaller lengths, as required, were taken as directed by the Engineer-in-charge. Under no circumstances coring was continued when it is obvious that the core barrel is blocked. This would have result in grinding down of the rock and loss of core. In zones of highly fractured rock or where the barrel continually becomes blocked, use of short run was observed.

#### **h) Observations During Drilling**

The ease or difficulty of drilling and speed of drilling at different depths was carefully recorded during drilling. The returning drill water was kept constantly under observation and its character such as, its clarity or its turbidity, its colour etc. was recorded. If the returning drill water is turbid, the same was collected and the suspended matter were allowed to settle. The settled matter was preserved in a suitable container and kept in the core box at the appropriate place corresponding to the depth from which it is obtained. Depth of drill water losses, partial or full were accurately recorded during drilling. Drilling time or penetration time for each bit were recorded and indicated in the column for time required for drilling.

#### **i) Extraction of Cores**

Core barrels were held horizontally, while cores are extruded, by applying a constant pressure without vibration and in a manner to prevent disturbance to cores. Each piece of core was sequentially numbered from top downwards as soon as the core pieces were removed from the core barrel. The serial number of each piece has been neatly painted on the respective piece with good quality paint. Arrows indicating the lower end of the piece and the number of drill holes that has be painted on each core piece. Sketch pens, marker pens, ball pens, lead pencils etc. were not used for marking the core pieces. The length of each core piece has been measured and recorded.

#### **j) Storing of Core Pieces and Core Boxes**

All core pieces are placed in core boxes in a serial order in correct sequence from top downwards. For each bore hole there are several core boxes. Core has been placed in the box with the shallowest core to the top left-hand corner and for every compartment the shallower core is to the left, the top being considered adjacent to the hinged section. Core boxes at the end of each day's work were stored. Core boxes are made according to specifications laid down in IS 4078:1980. Each of such boxes were sequentially numbered in the sequence in which the boxes used to store core pieces. The following is neatly painted on the lid of the core boxes, both on outside and inside and inside surfaces using pre-cut stencils and good quality enamel black paint.

Name of the project:

Location of bore hole:

Core Box No. :

Depth of core contained: From .....m to ..... m

The bore hole number and the core box number has been painted on all four vertical sides outside, with good quality enamel black paint.

#### k) Photographing of Core Boxes

Colour photographs of cores in each box have been obtained as soon as practicable after completion of a borehole. Photographs are necessary to permit the engineer or geologist to review the nature of rock as required at subsequent times. Further photographs will provide a record of the correct sequence of the core pieces in case the core box is spilled accidentally, or cores are not returned to the proper place after examining them. The photographs have been taken from directly above the box with the lid open. The format for reference number for each photograph shall be given below:

Photograph No. /Borehole No/ Core box No \_\_ of \_\_





Figure 5.5: Core Boxes.

#### l) Examination of Soil Samples, Rock Cores & Final Bore Hole Log

On completion of each bore hole, the soil samples and cores examined and logged by Engineering Geologist. For each bore hole, the final log of sub-surface explorations shall be prepared by Engineering Geologist, which shall comprise of the following:

- Bore log in overburden soil:
- Geological log of the Rock.

These final logs shall be prepared on the basis of the Daily Drill Reports, the Consolidated Drilling Log, visual examination of the soil samples and rock cores and laboratory testing data. Boring logs shall contain the date when the boring was made, the location of the boring with reference to the co-ordinate system used for the site, the depth of the boring and the elevation with respect to a fixed datum. The logs shall also include the elevation of the top and bottom of boring and the level at which water table and the boundaries of soil and rock strata were encountered. The classification and description of soil and rock layer, percent recovery of rock core, quality of core lost or not recovered for each core interval or drill run and Rock Quality Designation (RQD). Results of field permeability tests and bore hole logging shall also be included on logs. The type of tools used in making the boring shall be noted. Notes shall be provided of everything significant to the interpretation of sub-surface conditions such as lost drilling fluid, rod drops and changes in drilling rate. Incomplete or abandoned boring shall be described with the same care as successfully completed borings. The geological log of bore holes shall be prepared in line with IS: 4464-1985. Driller's log has been provided in Annexure 3.3.

#### m) Plugging Of Bore Holes

The boreholes except that meant for future monitoring of ground water level, shall be backfill with available soil in such a manner that no subsequent depression is formed at the ground surface due to settlement of the backfill.

#### n) Ground Water

Ground water table was observed after dewatering the borehole by suitable method and waiting for time period of 24 hours to allow for recuperation of ground water.

### Field Tests

Following field tests were conducted to evaluate design parameters,

1. In-situ permeability test by Pump-in Test
2. Pressure meter test in rock/soil
3. Standard Penetration Test
4. Seismic Refraction Test
5. Electrical Resistivity

#### In-Situ Permeability Test

Field Permeability test are carried out to determine permeability of each subsurface strata encountered up to bed rock as well as to ascertain overall permeability of strata. The tests carried are by pumping in method. The stratum being tested was above water table. So, the pumping in test was conducted.

Detail methodology of Pumping-In Test is explained below

#### Applicable Standards

1. IS 5529: Code of Practice for In-Situ Permeability, (Part I) – Tests in Overburden.
2. Section-V, Technical Specifications, Tender No-NPCIL/CIVIL/GAPP-1&2/2011/TEN/16

#### a) Pumping-In Test

The tests give permeability of the material in the immediate vicinity of the bottom of the drill hole. It may thus be used for determining the permeability of different layers in stratified foundations and thus check the effectiveness of grouting in such formulations.

#### b) Falling Head Method

The test may be conducted both above and below water table but is considered more accurate below water table. It is applicable for strata in which the hole below the casing can stand and has low permeability; otherwise the rate of fall of the head may be so high that it may be difficult to measure.

- Equipment
- A drilling or boring set
- Driving pipe casing
- A pumped water supply or a number of drums of 100 litres capacity full of water

- Delivery hose pipe
- Arrangement for measuring water level in the test holes by water level indicator.
- Miscellaneous equipment's- stop watches, graduated cylinders pressure gauges, water meter and enamelled bucket for measuring discharge.

### 1. Test depth & Test Section:

Test section shall be selected between 1m and 3m based on the soil strata encountered.

### 2. Procedure:

The procedure is accordance with IS-5529 (Part I)

- Borehole should be drilled up to the bottom of the test horizon and the casing should be simultaneously driven up to top of the test section as the drilling of the hole is in progress.
- Wash the bore hole.
- Measure the depth of natural water table if any prior to the test.
- Fill the casing with water up to the top.
- Using stop watch and water level indicator, measure drop of water level in the casing after 1, 2, 5, 5.0, 7.5, 10, 15, 20, 25, 30, 35, 40, 45, 50, 55 and 60min.
- If permeability of soil is relatively high, fill up the casing with water before each observation and average permeability is worked out.

### 3. Records and Calculations:

The permeability by falling head method in an uncased hole should be obtained from the following relation determined by,

$$K = (d^2/8L) \times \log_e (L/R) \times \{(\log_e (h_1/h_2))/(t_2-t_1)\}$$

Where,

K = coefficient of permeability in cm/sec,

d = diameter of stand pipe in cm

L = length of test zone in cm

h1 = head of water in casing pipe at time t1 minutes in cm

h2 = head of water in casing pipe at time t2 minutes in cm

R = radius of hole in cm

### Pressure meter Test in Soil & Rock

The objective of the tests is to determine the deformation modulus, shear modulus, creep pressure and limiting pressure of in-situ soil stratum. The aim of the tests is to determine the in-situ deformation modulus of soil using an expanding probe to exert pressure on the wall of a drill hole. The resulting diametric hole expansion (dilation) is determined from measurements of the volumetric expansion of the probe. Deformability characteristics of the soil stratum at the dilatometer location may be calculated from the relation between pressure and dilation.

Applicable Standards: IS 12955: (Part 1&2) - In-Situ Determination of Rock Mass Deformability Using A Flexible Dilatometer.

#### a. Site Calibration:

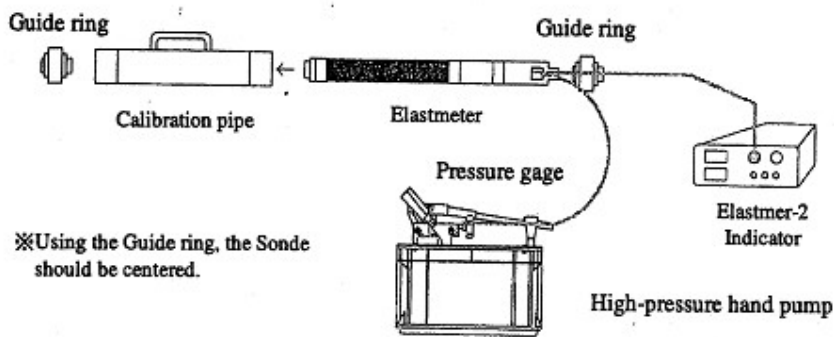

**Figure 5.6: Calibrating the Pressure output**

The internal displacement callipers and the rubber membrane will be calibrated at regular, appropriate interval throughout the field work. The callipers will be calibrated over the membrane displacement/expansion range using calibration ring. A thickness variation calibration will be regularly performed on rubber membrane, pressurized over the testing pressure range within a rigid steel calibration sleeve. The results of the calibrations shall be used, in accordance with manufactures calculations procedures, to apply correction to the borehole wall deformation readings, to account for membrane thickness variation during testing.

#### b. Test Procedure:

- NX size bore hole is drilled up to the desired depth. Casing will be provided up to suitable depth in the borehole.
- Calibrated probe will be placed at desired test depth and pressure will be applied in equal increment of 0.5 Mpa.
- At each load increment the pressure is held constant for the period of 60 second.
- Application of pressure increment will be up to failure point or maximum specified pressure (100 bars).
- The test will be terminated at the maximum pressure were no further increase in the pressure observed with increase in the deformation reading.

**c. Interpretation:**

- The ground coefficient (K) & Pressure-meter modulus (Ep) will be determined from the liner a pseudo elastic deformation zone of the load deformation curve as follows

$$K = \Delta P / \Delta R$$

$$E_p = (1 + \mu) * R_{av} * K$$

Where,

K = Ground coefficient (MN/m<sup>2</sup>)

$\Delta P$  = Pressure interval (MPa)

$\Delta R$  = Radius interval (m)

E<sub>p</sub> = Pressure-meter Modulus (MPa)

$\mu$  = Poisson's Ratio

R<sub>av</sub> = Intermediate Radius (m)

- The volume changes at 60 sec. Vs. pressure will be plotted gives in situ stress strain curves.
- Recommendations will be given regarding deformation modulus.

**Standard Penetration Test (Ref.IS: 2131-1981)**

Tests were conducted at intervals of 3 m depth and/or change of strata up to depth the soil depth or change of strata. The sampler was lowered to the bottom of the borehole. The following information were noted and recorded:

- Depth of bottom of borehole below ground level.
- Penetration of the sampler into the soil under the combined weight of sampler and rods (to be noted from readings of the scale over the drill rod at the top)

- Water level in the borehole and
- Depth of bottom of casing below ground level.

The split spoon sampler resting on the bottom of borehole was allowed to sink under its own weight; then the split spoon sampler was seated 15 cm with the blows of the hammer freely falling through 75 cm. Thereafter the split spoon sampler was further driven by 30 cm or 50 blows (except that driving shall cease before the split spoon sampler is full). The number of blows required to affect each 15cm of penetration were recorded. The first 15 cm drive was considered to be seating drive. The total blows required for the second and third 15cm of penetration were termed the penetration resistance 'N'; if the split spoon sampler is driven less than 45 cm (total), then the penetration resistance for the last 30 cm of penetration (if less than 30 cm is penetrated, the logs should state the number of blows and the depth penetrated). The entire sampler may sometimes sink under its own weight when very soft sub-soil stratum is encountered. Under such conditions, it may not be necessary to give any blow to the split spoon sampler and SPT value should be indicated as zero. If, on lowering the sampler by means of a string of rods, it is found to rest at a level above the bottom of the casing, the penetration test and sampling was not carried out at that stratum. The drive hammer was of the type of an automatic trip mechanism to insure free fall.

## Geophysical Tests

### Objectives of Geophysical Tests

To carry out geophysical investigations (ERT and SRT) for Thane-BORIVALI Road tunnel Project through Sanjay Gandhi National Park.

- Length of the twin tunnel: 10.2 km (approx.)
- Depth of interest: Minimum 30 m.

There will total 8 lines, 2 lines of length 150 m parallel to the tunnel alignment and 2 lines of length 70m perpendicular to the tunnel alignment at both the portal location for SRT.

The main objectives are:

### Soil/Rock Interface:

Precise determination of Soil layer thickness and the rock head level, The bedrock profile, quality of rock with respective to depth & Precise determination of Water table.

### Rock quality:

Weathering of rock, fractured and weak zones, To detect anomalous zones or water bearing formation (any localized area where large volume of water inflows expected during excavation), Loose pocket of rock OR Inter trapean beds (Completely weathered/ clay pocket/shale rock between two continuous basalt flows),

Discontinuities or jointing nature of rock (Like Highly/moderately jointed rock) & Information on weak zones/buried channels in b/w the competent rock.

**Rip ability Assessment:**

Velocity profile with respect to depth, Localization and identification of different lithological/geological units, A drawing showing till what depth, rock can be excavated and from which depth, blasting is required, A continuous rock profile for tunnel length & Q value estimation w.r.t depth (Empirical correlation).

**Note:** A 3-D profile at the end showing all the anomalous zones/ water bearing formation with respect to depth.

**Seismic Refraction Test**

The seismic refraction method is a geophysical method to determine the subsurface velocity structure through an analysis of the seismic waves that return to the ground surface after refraction at the boundaries of subsurface layers with different seismic velocities. It has been widely used for many years in civil engineering applications.

Although there are several types of seismic refraction methods depending on the survey objectives or targets, the most common methods are based on the first arrivals of P-waves. The digital measuring equipment for seismic refraction surveying is becoming increasingly more compact and offers multi-channel recording capability.

Data processing techniques increasingly employ automated analysis. In addition, seismic tomographic data processing techniques must derive more detailed velocity structures. The seismic refraction method is based on the analysis of artificially created seismic waves that are generated from the surface. Those waves travel to a particular depth and return to the surface after refraction at the boundaries of layers with different seismic velocities.

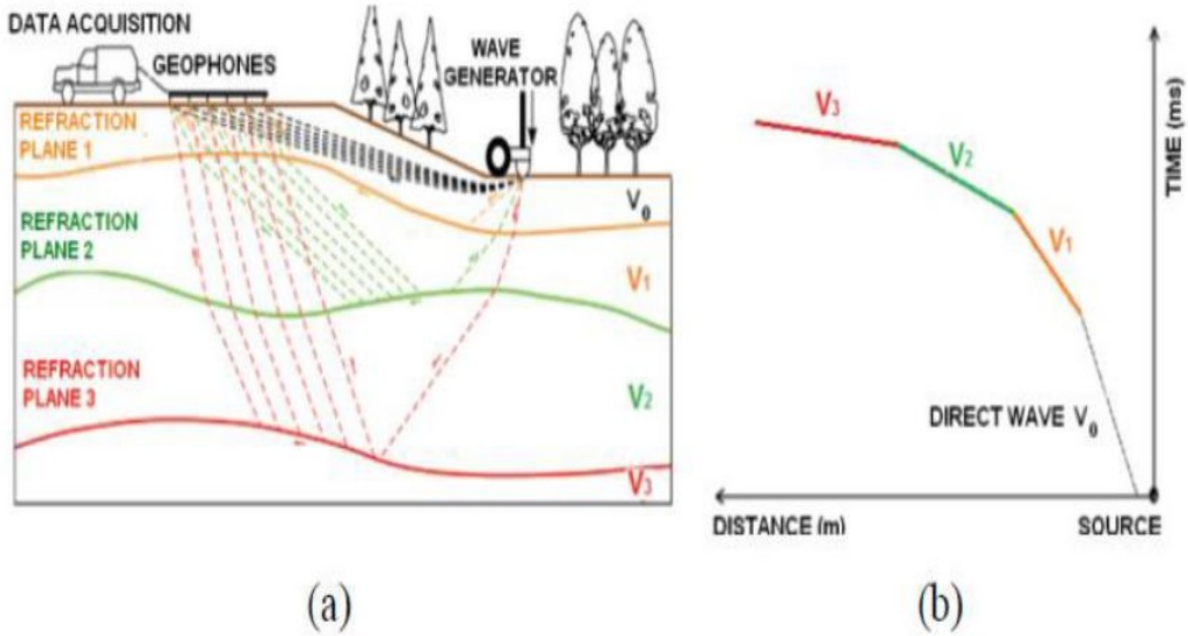

Figure 5.7: Seismic Refraction Method (a) Data Acquisition (b) Distance -Time diagram

### 1. Applicability

The seismic refraction method is applicable in situations where the P-wave velocity increases with depth. Since this is the usual situation in the near surface in a rock site, the method has been used widely for site characterization in road construction, dam construction and tunnelling projects.

The depths to the various layers can be determined and the seismic velocities estimated by the method can be utilized to determine lithology, rock strength, and crack density, degree of weathering or metamorphism, and locations of fault zones. Some of the applications are:

- Stratigraphic mapping, Estimation of depth to bedrock.
- Estimation of depth to water table, predicting the Rippability of specific rock types.
- Locating sinkholes, Landfill investigations & Geotechnical investigations

### 2. Planning

#### a. Study of existing information

In this study, a review should be made of existing information including borehole data, the topography, the geology, the depth to the water table, the degree of weathering, the possibility of thin layers and layers associated with velocity inversions, and dips of possible faults at the survey site.

#### b. Arrangement of the survey line(s)

The survey lines should be prepared in consideration of the survey objectives, the depth of investigation, the geological conditions and the topography. The location and length of the survey lines, the source and

receiver intervals and the maximum offset distance between sources and receivers are basic parameters in planning a seismic refraction survey.

The seismic refraction method can accommodate rough topography, but it is desirable to arrange survey line(s) to avoid extremely rough terrain.

Because the seismic refraction method derives two-dimensional (2-D) depth profiles, the survey lines should be arranged perpendicular to the strike of the target geological structures and boundaries. Setting up a survey grid will provide tie lines and facilitate delineation of targets in three dimensions.

The minimum length of the survey line is determined by the depth of the expected targets and the velocity structure. As a rule of thumb, this is generally around 5–10 times of the depth of investigation.

### **c. Intervals of source and receiver points**

In most civil engineering applications for the seismic refraction method, the depth of investigation is within several tens of meters. In these cases, 10-m geophone intervals are usually adequate but for shallower targets, this interval can be reduced to 5 m or less.

During the survey, the geophones will be arranged in spreads of 24 geophones. These will be used to simultaneously measure the seismic waves arriving from a single source. For long lines, spreads should be run end to end.

For the deepest layer (the main refractor), this coverage is mainly achieved by the remote shots. For the intermediate layers, the coverage is obtained using sources within the spread. It is generally recommended that these source points should be at intervals of 30-60 m.

### **d. Types of seismic sources**

In this case of shallow surveys where the depth of investigation is less than 30 m, hammers and weight drops are used as alternate, non-explosive sources.

## **3. Field operation**

### **a. Equipment:**

Survey equipment generally consists of geophones (receivers), geophone cables with connecting take outs, extension cables, a data acquisition system (including amplifiers, display and recording facilities) and Hammer. Geophones typically have a natural frequency of 30 Hz or less and are damped to ensure that there is not a strong resonance at the natural frequency. All instruments have undergone routine checks prior to use.

### **b. Positioning of the survey line**

The locations and elevations of the survey line, the geophones and shot points need to be determined by appropriate surveying. If there is more than one spread of geophones in a line, the ends of each spread should overlap so that continuity in the travel time data can be preserved.

**c. Preparation for the measurement**

To obtain good signals, all geophones should be planted firmly into the ground. They should be connected via take-outs to the geophone cable so that there is the same polarity for all geophones. The instant of shot detonation starts the recording process. This time can be transmitted from the shot point via radio or via a cable.

**d. Measurement**

The observer needs to maintain an observer's log detailing the locations of all geophones within a spread, the locations of the shots, the shot record numbers and the depth of each shot hole. The observer needs to monitor amplifier gains and/or filtering parameters to ensure the quality of the recorded data. If necessary, repeated measurements should be made to obtain better quality data.

**e. Completion of survey**

At completion of the survey, all equipment needs to be retrieved and cleaned. The site needs to be rehabilitated in accordance with the client's requirements. The observer needs to ensure that all seismic data, observer's logs and relevant survey information is properly archived and available for data processing and interpretation.

**4. Data processing**

**a. Arrangement of the field data**

All field data—seismic recordings (shot records), observer's logs and survey information need to be organized and compiled for a processing sequence of the type illustrated in Fig. 5-8. This is a standard processing sequence. There are other ways of processing and interpreting data, for example by using ray tracing techniques and through tomographic inversion.

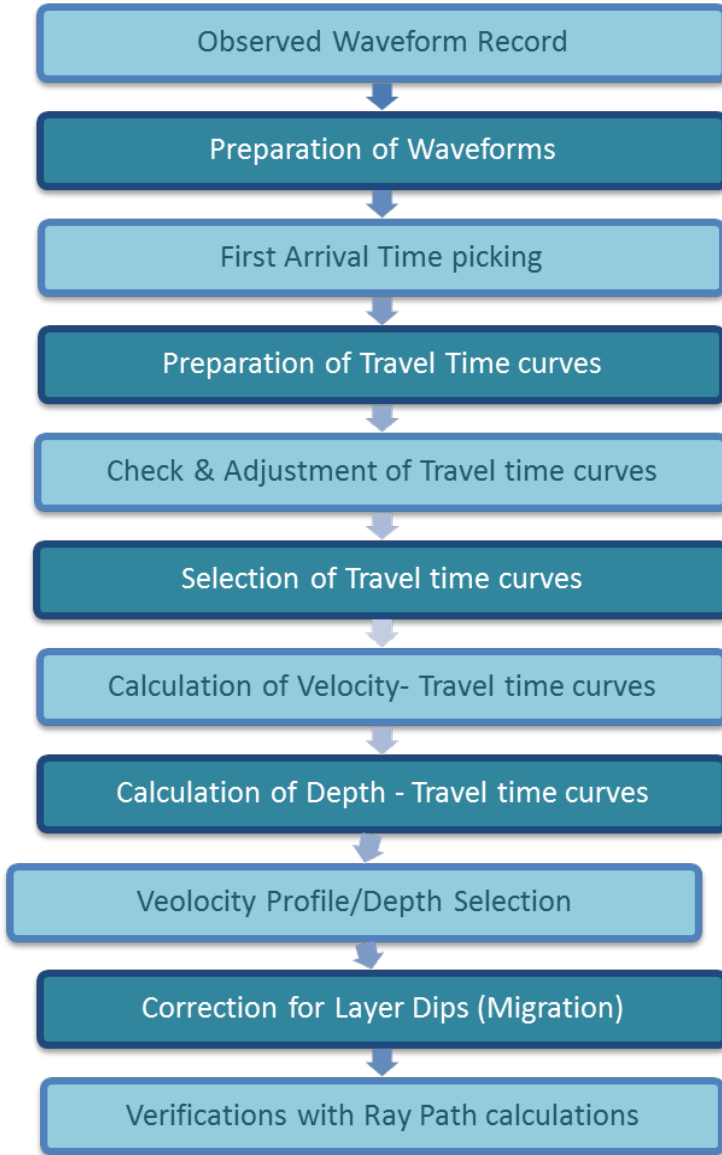

**Figure 5.8: Flow chart for Data Processing**

**b. Picking first arrivals**

First of all, the first arrival times of the refracted P-waves are picked on the shot records in order to construct travel time curves. Usually, first arrival times are picked with a time resolution of around 1 ms. For a high precision survey, time resolution is often less than 0.1ms. Picking can be done manually on printed seismic records or using automatic and interactive computer techniques.

**c. Construction of the travel time curves**

Based on the distance along the survey line, the receiver intervals (geophone spacing) and the first arrival times, travel time curves are plotted with the horizontal axis being distance and the vertical axis travel time. For hard copy travel time curves, typical scales are 1/500 or 1/1000 for the distance axis and 5 or 10ms to the cm for the vertical axis, see Fig. 5-9.

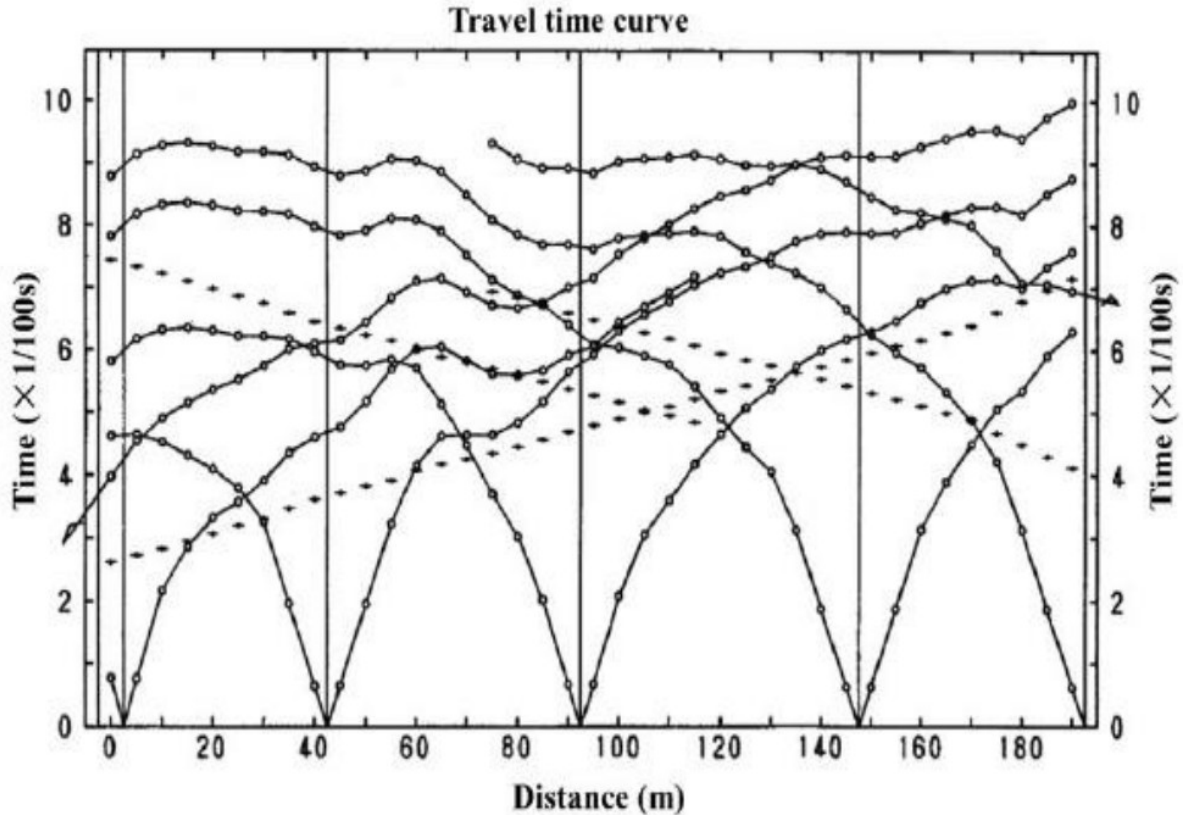

Figure 5.9: Example of travel time curves

#### d. Checking of the travel time curves

The travel time curves should be checked and corrected, if necessary, on the basis of the following:

- Reciprocity of the travel times. (Travel times between a pair of shot points should be equal.
- At each shot point, coincidence of intercept times from each of the refractors
- Parallel travel time curves when different shots provide travel times to the same refractor at the same locations. Bulk shifts in travel times can be used if it is decided that there is a constant delay, due to errors in the up-hole correction. Individual travel times may need to be adjusted after further consideration of the shot records.

#### e. Derivation and verification of the velocity profile

The number of refractors present in the travel times is determined on the basis of the number of changes in slope and the degree of parallel behavior observed on the travel time curves. The 2-D velocity profile (depth

section) under the survey line is then obtained by analyzing the travel time curves using techniques such as the generalized reciprocal method (GRM) and Hagiwara's method.

An intermediate step for these methods involves determining the velocities of the P-waves in each of the refracting layers present. Verification of the depth section using ray tracing to calculate synthetic travel time curves is desirable. These can be plotted on the corresponding observed travel time curves.

### 5. Interpretation

- I. The depth section thus obtained is generally interpreted in consideration of the survey objectives, existing data and additional or supplemental profiles if available.
- II. If the travel time curves can be interpreted by two or more different models, it is desirable to report on all possible interpretations. These situations typically arise when hidden layers and velocity inversions are present.
- III. The P-wave velocities obtained with a seismic refraction survey can be used as an indicator of rock quality for designing a construction such as a tunnel and a dam in rock engineering applications.
- IV. Fig 5.10 shows an example of the resultant depth section.

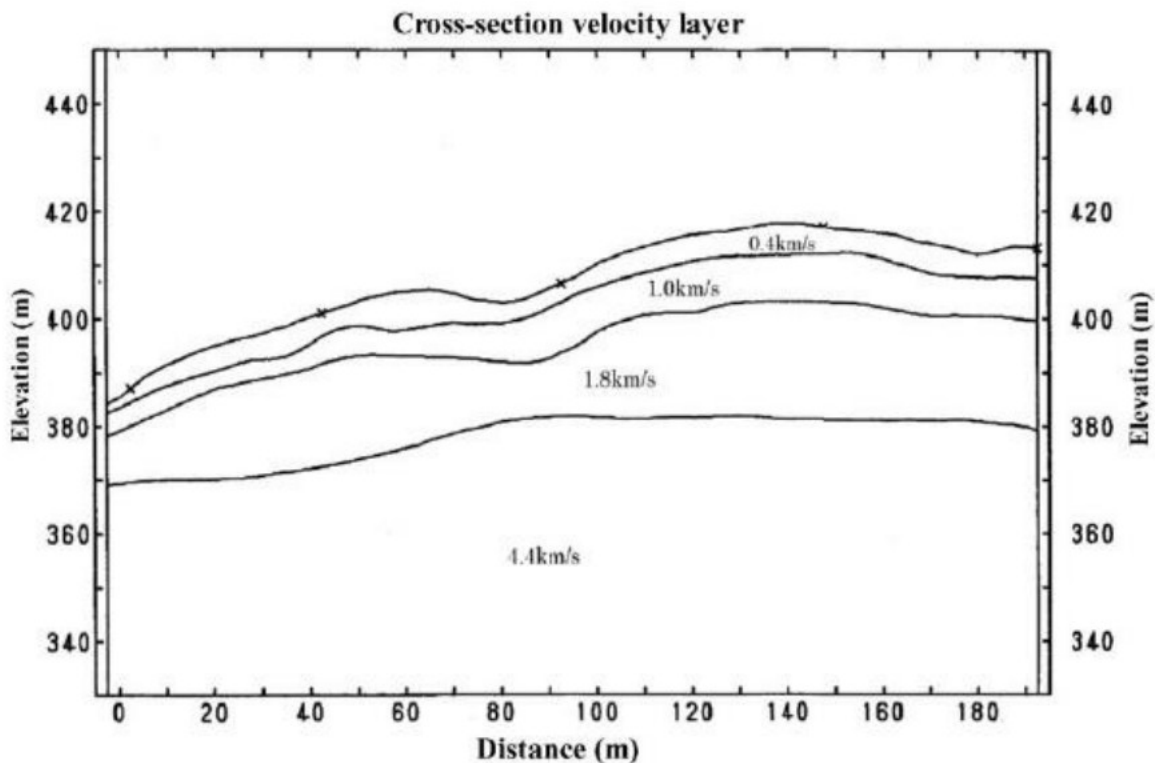

Figure 5.10: Resultant velocity/depth profile

## 6. Output and report

Outputs of a seismic refraction survey should include at least the following:

- I. Location map of the survey site;
- II. Layout of survey lines;
- III. Observer's logs;
- IV. Shot records (in digital form);
- V. Travel time curves;
- VI. Velocity profile verified with ray paths.

### Electrical Resistivity Test of Soil – Geophysical Method of Soil Exploration

This method depends on differences in the electrical resistance of different soil (and rock) types. The flow of current through a soil is mainly due to electrolytic action and therefore depends on the concentration of dissolved salts in the pores. The mineral particles of soil are poor conductors of current. The resistivity of soil, therefore, decreases as both water content and concentration of salts increase.

- Dense clean sand above the water table, for example, would exhibit a high resistivity due to its low degree of saturation and virtual absence of dissolved salts.
- Saturated clay of high void ratio, on the other hand, would exhibit a low resistivity due to the relative abundance of pore water and the free ions in that water.

There are several methods by which the field resistivity measurements are made. The most popular of the methods is the **Schlumberger method or by four pin Wenner method** as per IS: 3043

We shall be using four pin Wenner method which is further explained in detail.

### Wenner method as per IS: 3043

#### 1. Test Procedure

The Wenner arrangement consists of four equally spaced (A) electrodes driven approximately 20 cm into the ground as shown in the following figure.

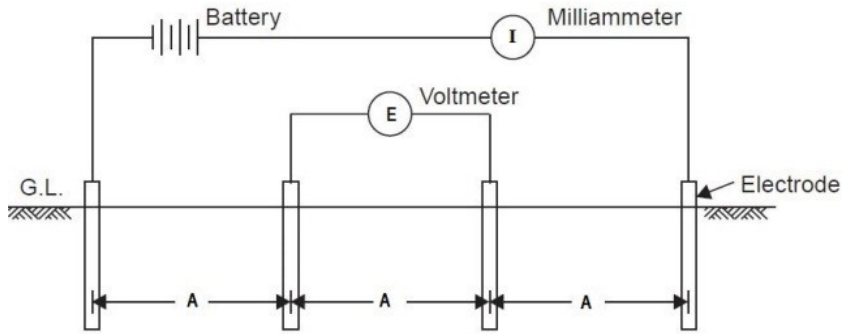

Figure 5.11: Wenner's Arrangement for Electrical Resistivity Test of Soil

In this method a DC current of known magnitude ( $I$ ) is passed between the two outer (current) electrodes, thereby producing an electric field within the soil, whose pattern can be determined by the resistivities of the soils present within the field and the boundary conditions. By means of the inner electrodes the potential drop 'E' for the surface current flow lines is measured. The apparent resistivity 'R' is calculated using the following equation.

$$R = \frac{2\pi AE}{I}$$

Where,

A in meters,

E or V in volts,

I in amperes, and

R in ohm-m

The apparent resistivity represents a weighted average of true resistivity to a depth A in a large volume of soil, the soil close to the surface being more heavily weighted than the soil at greater depths. The presence of a stratum of low resistivity forces the current to flow closer to the surface resulting in a higher voltage drop and hence a higher value of apparent resistivity. The opposite is true if a stratum of low resistivity lies below a stratum of high resistivity.

The method known as electrical sounding is used when the variation of resistivity with depth is required. This enables rough estimates to be made of the types and depths of strata. A series of readings are taken, the (equal) spacing of the electrodes being increased for each successive reading. However, the centre of the four electrodes remains at a fixed point. As the spacing is increased, the apparent resistivity is influenced by a greater depth of soil. If the resistivity increases with the increasing electrode spacing, it can be concluded that an underlying stratum of higher resistivity is beginning to influence the readings. If increased separation produces decreasing resistivity, on the other hand, a lower resistivity is beginning to influence the readings. Apparent resistivity is plotted against spacing, preferably, on log paper. Characteristic curves for a two-layer structure are shown in the following figure.

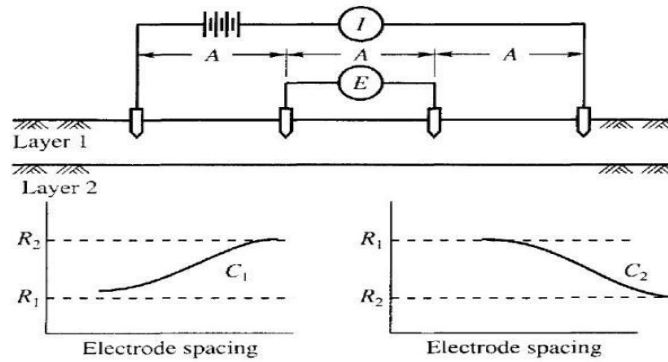

Figure 5.12: Electrical Resistivity Test – Schematic Representation

For curve  $C_1$  the resistivity of layer 1 is lower than that of layer 2; for curve  $C_2$ , layer 1 has a higher resistivity than that of layer 2. The curves become asymptotic to lines representing the true resistance  $R_1$  and  $R_2$  of the respective layers. Approximate layer thickness can be obtained by comparing the observed curves of resistivity versus electrode spacing with a set of standard curves. The procedure known as electrical profiling is used in the investigation of lateral variation of soil types. A series of readings is taken, the four electrodes being moved laterally as a unit for each successive reading; the electrode spacing remains constant for each reading of the series. Apparent resistivity is plotted against the centre position of the four electrodes, to natural scale; such a plot can be used to locate the position of a soil of high or low resistivity. Contours of resistivity can be plotted over a given area. The electrical method of exploration has been found to be not as reliable as the seismic method as the apparent resistivity of a particular soil or rock can vary over a wide range of values. Representative values of resistivity are given in the following table.

## 2. Interpretation

- I. To avoid misinterpretation of the processed resistivity image, it is important to understand restrictions and limitations of the inverse method. It is recommended to refer to additional or other information about the survey site.
- II. Resistivity varies with various factors such as rock type, porosity, water saturation, and ground water resistivity, clay content associated with weathering or alteration, and temperature. Lower resistivity generally indicates higher clay content or higher water content (i.e., the porosity multiplied by water saturation).
- III. Geotechnical parameters such as hydraulic conductivity and porosity of the ground can be estimated from the resistivity values using empirical or experimental equations.
- IV. Low resistivity portions were interpreted as high water content zones.

Representative values of resistivity. The values are expressed in units of $10^3$ ohm-cm(after Peck et al, 1974)	
Material	Resistivity (ohm-cm)
Clay and saturated silt	0 – 10

Sandy clay and wet silty sand	10 – 25
Clayey sand and saturated sand	25 – 50
Sand	50 – 150
Gravel	150 – 500
Weathered rock	100 – 200
Sound rock	150 – 4000

**Table5.2: Typical values of Resistivity**

### 3. Laboratory Tests

Lab tests will be conducted (as per relevant IS & ASTM code) on soil and rock samples to determine their properties which may be used for design and geotechnical evaluation.

Sr. No	Test Description	Relevant IS/ASTM code
A	<b>Rock Tests</b>	
1	Water absorption	IS:1124
2	Moisture Content	IS 13030
3	Porosity	IS: 13030 / IS 1124
4	Dry density	IS 13030 / IS 1124
5	Crushing strength (UCS)	ASTM – D2938
6	Point load test	ASTM – D
7	Tensile strength (Brazilian)	IS 10082
8	Durability-	IS: 10050
9	Specific gravity	IS 13030 / IS 1124
10	Abrasivity Test (Cercher Abrasivity Test)	ASTM (2010): D7625-10
11	Unconfined compression	IS: 9143
12	Point load tests	IS: 8764
13	Triaxial compressive strength	ASTM D 2664
14	Youngs Modulus and Poisson ratio	IS 9221

15	Petrographic Study (Including Thin Sections)	ASTM C1721
B	<b>Chemical Tests</b>	
1	Soil Chemical Test	IS : 2720 (Part 26, 27)
2	Water Chemical Test	IS 3025 Method of Sampling & Testing

**Table 5.3: Relevant Codes for Lab Tests**

Point load strength index is often used to predict uniaxial compressive strength. On average, uniaxial compressive strength is 20 to 25 times point load strength. However, the ratio can vary between 15 and 50, especially for anisotropic rocks.

#### 4. Logging Procedures

In logging the exploration pit/borehole, a vertical profile should be made parallel with one pit wall or borehole. The contacts between geological units should be identified and drawn on the profile, and the units sampled as recommended by geotechnical consultant. Sampling should be made as per SP: 36 (Part – 2) – 1988 for disturbed samples and IS: 8763 – 1978 (sand), IS: 10108 – 1982 (fine grained soil) for undisturbed samples. Characteristics and type of soil or lithologic contacts should be noted. Variation within the geologic unit must be described and identified and indicated on the pit /borehole log wherever the variation occurs. The sample locations should be shown in the respective log and their location written on a sample tag showing the station location and elevation. Ground water should also be noted on the exploration pit/borehole log.

#### Field Data

Boreholes Details & observations for proposed Thane-Borivali Highway Tunnel are presented in this section. A preliminary site model was developed using the information obtained from existing data and the site visit. The model should be divided into zones of interest (i.e., geotechnical units) based on the necessary design parameters and objectives. This model will obviously change as results of the detailed investigation are collected. Following information was collected during the site reconnaissance stage.

Sr. No	Checklist Item	Sub-Item	Description
1	Accessibility		Easy
2	Visit to site	Date and time	20 <sup>th</sup> Dec to 02 <sup>nd</sup> March 2018
		Visitors	M/s Jay Gajanan, & Aecom's Engineers
		Weather condition	Sunny Season
		Temperature	28 to 32 <sup>o</sup> Centigrade
3	Ground Cover		Grass & Small Bushes
4	Existing Terrain		Hilly Terrain

5	Site Hydrology	Surface water	N.A
		Subsurface water	Encountered in boreholes
6	Site Drainage		Existing drainage system
7	Soil and rock conditions	Surface soil	Hard Brownish Clayey Sand mixed with boulders
		Subsurface soil	Stiff Clay with Gravels
		Rock features	Weathering Basalt
8	Investigative Operation		Seventeen Boreholes
9	Prior information		Site Observations
10	Geological information		NA

**Table5.4: BH data collected during site reconnaissance**

Total twelve boreholes were drilled for Thane – Borivali Highway Tunnel in present investigation. Out of 12 borehole 3 boreholes were drilled at Thane side & 9 boreholes along the tunnel alignment. Boreholes were drilled up to maximum 115 m depth from the existing ground level. Ground water tables were observed in all boreholes. Driller’s log and Borehole details are as follows.

Borehole detail & Driller’s Log are further divided into two part

1. Boreholes inside SGNP
2. Boreholes outside SGNP

**Boreholes inside SGNP**

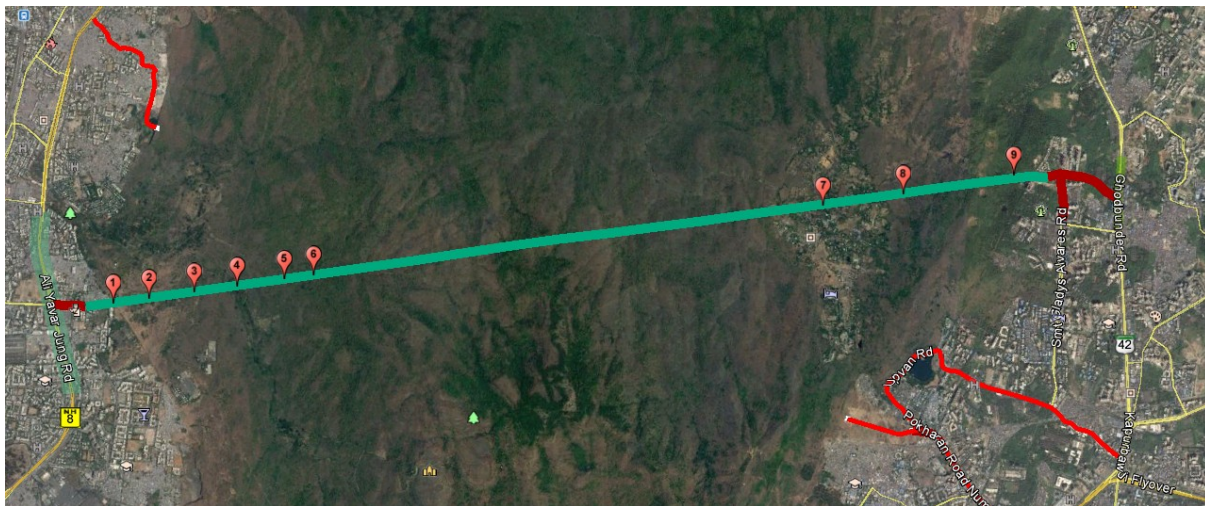

**Figure 5.13: Location Plan for Boreholes inside SGNP**

**Borehole Details**

BH no.	Location	Latitude	Longitude	RL m
1	SGNP	19°13'19.36"N	72°52'18.15"E	25.40
2	SGNP	19°13'21.97"N	72°52'31.33"E	26.30
3	SGNP	19°13'25.38"N	72°52'48.19"E	34.23
4	SGNP	19°13'28.56"N	72°53'4.27"E	35.01
5	SGNP	19°13'32.15"N	72°53'21.74"E	47.5
6	SGNP	19°13'34.42"N	72°53'32.65"E	62.4
7	SGNP	19°13'37.38"N	72°53'47.74"E	71.3
8	Yeoor	19°14'11.70"N	72°56'40.90"E	114.2
9	Yeoor	19°14'15.29"N	72°56'55.90"E	123.3

**Table 5.5: Borehole details**

**Status**

All 9 Boreholes inside SGNP has been completed on 31<sup>st</sup> July 2018. Desire samples are sent for testing. Permeability test and Pressure meter test completed at 4 locations.

**Core-box sample**



**Figure 5.14: Core-box Sample**

**Driller's Log**

. Driller's Logs sample is attached below. Detail Drillers log are attached in annexures.

JAY GAJANAN GEOTECHNICS

JOB NO. : 29

CLIENT : M/S. AMIAND CONSULTING PVT. LTD.													
PROJECT : Geotechnical Investigation for Proposed Highway Tunnel Project Tikujiniwadi-Borivali, Mumbai													
BORE HOLE NO. : BH-3				SHEET NO. : 1 OF 4									
LOCATION : SGNP				DATE : 01/06/2018 TO 12/06/2018									
CO-ORDINATES : N 19°13'25.38", E 72°52'48.19"				METHOD : ROTARY DRILLING									
GROUND P. L. : -				CASING : 100mm 1.50m & NX Ø BGL									
GROUND W. T. : -													
DEPTH (m.)	DIA. OF BORE HOLE	LOG.	STRATA DESCRIPTION	SAMPLE		BLOWS/15cm				SPT N	C R %	RGD %	OTHER TESTS
				DEPTH (m)	TYPE	15	15	15	15				
1.00	100 mm Ø		Filling materials (Yellowish, silty SAND with murum	0.00	DS1								
				0.50									
2.00			Boulders	1.50/									
3.00				3.00/									
4.00				4.50/									
5.00			Stiff, yellowish, silty CLAY with gravels	5.10	SPT1	03	05	08	15	13			
6.00				6.00/									
7.00				6.60	SPT2	04	07	09	25	16			
8.00				7.50/									
9.00			Boulders	8.10	SPT3	05	08	13	17	21			
				9.00/			05	-	-	-			
			Slightly weathered, greyish, BASALT	9.05	SPT4	52	-	-	-	k			
10.00						CORE	1 TO 6				76	61	

SPT N = STANDARD PENETRATION TEST VALUE    RGD = ROCK QUALITY DESIGNATION    UDS = UNDISTURBED SOIL SAMPLE  
 CR = CORE RECOVERY    DS = DISTURBED SOIL SAMPLE

REMARKS : CONTINUED ON NEXT PAGE.

Address: Shubharambh Residency, 703 A-Wing, Pada No.03, Lokamanya Nagar, Thane(W) Pin: 400 606(MS)  
 E-Mail : geojaygajanan@gmail.com

Figure.15: Sample Driller's log



**Bore Hole No. 1**



**Bore Hole No. 2**



**Bore Hole No. 3**



**Bore Hole No. 4**



**Bore Hole No. 5**



**Bore Hole No. 6**



**Bore Hole No. 7**



**Bore Hole No. 9**



Bore Hole No. 8

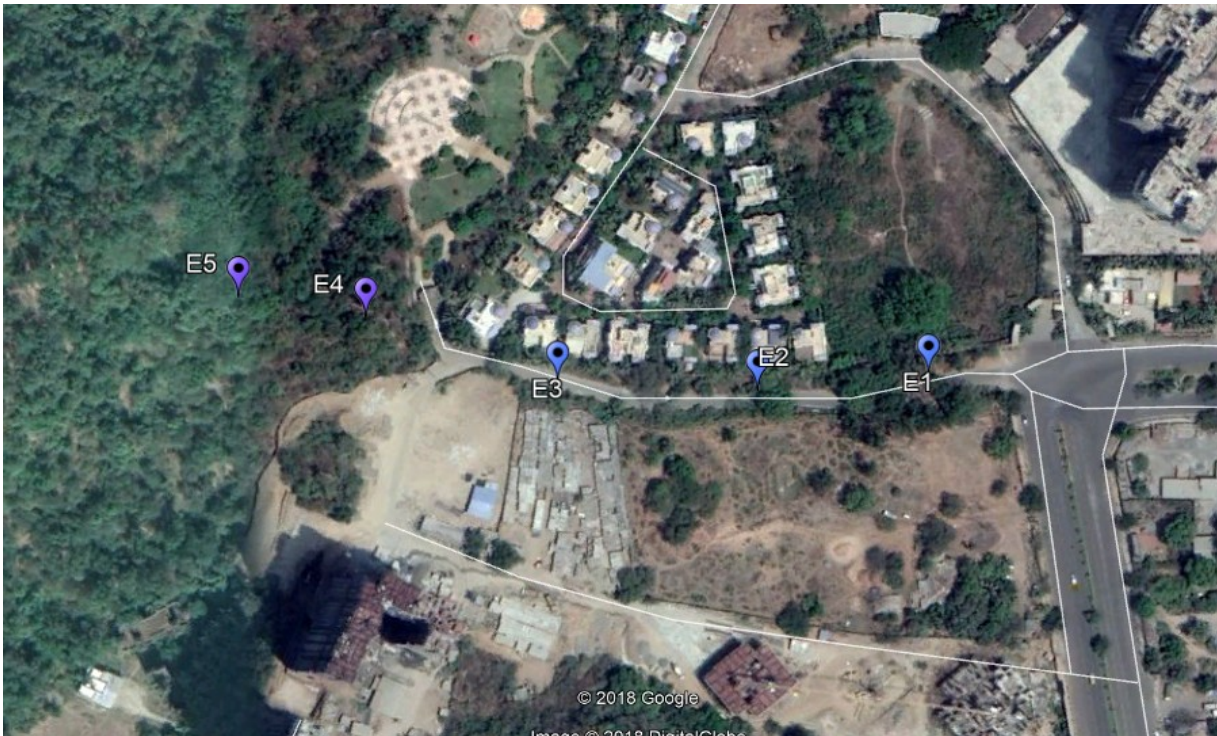

Figure 5.16: Location Plan for Boreholes near Eastern portal

BH no.	Location	Latitude	Longitude	RL m	Status
--------	----------	----------	-----------	------	--------

E1	Manpada Eastern Portal	19°14'29.43"N	72°58'7.54"E	45.31	Completed
E2		19°14'29.20"N	72°58'4.99"E	44.48	Completed
E3		19°14'29.33"N	72°58'2.01"E	42.40	Completed

## Chapter 6-Detailed Report for TBM Tunnels

### 6.0 General Geological Information

The project area is located approx. between the Latitude 19° 10' to 19°19' and Longitude approx. 72°45' to 73°. The project comprises of approx. 10.25 km long tunnel between Thane to Borivali. The coastline of the area trends almost N to S with a number of creeks, prominent among these being Dahanu Creek, Vasai Creek and Thane Creek. The main physical features of the land are the coastal plains and the hilly tracts to the east. Project is situated between Borivali to Thane in Maharashtra. The area is drained by tidal rivers like Ulhas river, Vaitarna river and their tributaries. The rivers run down to the western scarp of the Western ghats into the Arabian sea.

The entire land area is occupied by Deccan Basalt and associated Volcanic, pyroclastic and Plutonic rocks which include agglomerate and tuffs, volcanic breccia, trachyte, diorite, Granodiorite and Gabbro. They are profusely intruded by basic dykes. A major arcuate fault, convex eastward from Saphale in the middle of the area to Bombay city in the south separates the sequence of pahoehoe flows to the north and east of the fault from 'aa' flows and associated volcanic and plutonic rocks exposed to the west of the fault. The area to the west of the arcuate Thana fault exposes a sequence of various volcanic and plutonic rocks with a difference in setting from the area east of the fault. A sequence of aphyric basalt occupies about 60 percent of the area. The flows are exposed in Kamandurga Tungar area, around Dhanir, Shisad, Virar, in Borivali National Park, Malabar hill etc. extensive horizons of agglomerate exhibiting a general NNW-SSE trend occur near Kanan Shillotar, Chincholi and Kanheri Cave area.

The volcanic-plutonic complex exposed around Thana, bounded by arcuate fault zone has been suggested to be the result of Cauldron subsidence. A major fault extending North-South for about 50 km from Nandalpada in the North to east of Sephala in the South with an estimated throw of about 200 m has controlled the north south course of the Surya river and the NNW-SSE course of Vaitarna.

Another slightly arcuate fault parallel to the earlier fault extends for about 80 km from Kothipada in the north to Arande in the south with throw of about 300 m along the Vaitarna River.

The three flows constituting the Karla Formation (200m thick) are fine grained, dense and zeolite-rich aphyric flows. A number of Basalt and Dolerite dykes trending North-South and northwest southeast range in width from a few cms. Local features like dykes with intermittent volcanic neck like features near Akarpati and Nandgaon. The area to the west of the arcuate Thana fault exposes a sequence of the volcanic and plutonic rocks with a difference in setting from the area east of the fault. A sequence of aphyric aa flows, at places interbedded with tuffs, agglomerate and fine grained aphyric basalt occupy about 60 percent of the area. The flows are exposed in Kamandurga Tungar area, around Dhanir, Shirsad, Virar, in Bolrivali National Park, Malabar hill etc. extensive horizons of agglomerate exhibiting a general NNW-SSE trend occur near Kanan Shillottar, Chincholi and Kanheri Cave area. Occurrence of volcanic ash and breccia around Powai Lake area, silicic tuffs showing flow folding from Kora area, tuffs of compositions equivalent to intermediate lavas from

Dahisar and Dongre area, breccia plugs from Arnala Island and near Khairpada have been reported.

Basic and ultrabasic differentiates occur as plugs, stocks and pluton. Exposures of ankaramite occur in Panchkoli and Man Budruk. Gabbro intrusives occur east of Paygaon, near Kanheri, Pelhar and North Sendur Hill.

Acidic to intermediate intrusive rocks occur more predominantly in the western part of the area. Occurrence of diorite intrusive as stock near Sativali, trachyte interbedded with basalt (in Sakinaka quarry), at places also as dykes in basalt, sometimes also containing inclusion of basalt have been reported. Rhyolite is reported from Hanori-Dingri area, near Dahisar, in Borivali National Park and near Bhuigaon. A small granodiorite plug occurs near Pelhar.

The basalt flows of the area have been affected by the monoclonal flexure, the well-known 'Panvel Flexure'. In the axial zone of the monocline the gradient suddenly changes from 1 degree 30' to about 3 degrees. The pahoehoe flows exposed in the eastern part of the area, show increasingly westerly dips from 1 degree 30' to as much as 8 degree near Saphale. At places, the basalt flows have acquired steeper dips of upto 18 degrees. Around the area west of the arcuate fault a varying degree of dip from 15 degree to 35 degree has been noticed in the flows indicating disturbed nature of these rocks. The volcanic plutonic complex exposed around Thana, bounded by arcuate fault zone, has been suggested to be the result of cauldron subsidence. The magnitude of the subsidence has been tentatively estimated to be of the order of 600 m. A swarm of dykes along the coast from Mahian to Shirgaon with intermittent colcanic necks and a large-scale subsidence along it, is suggestive of major fissure zone in this area. A major fault extending North-South for about 50 km from Nandalpada in the North to east of Saphale in the South with an estimated throw of about 200m has controlled the North-South course of the Surya river and the NNW-SSE course of Vaitarna.

Another slightly arcuate fault parallel to the earlier fault extends for about 80 km from Kothipada in the north to Arnade in the south with throw of about 300m along the Vaitarna river. Thermal springs are located at Sativali Haloli, Paduspada and Koknere along North-South fault/fractures. The thermal spring at vakadi along the Surya river marks the fault lineament. Study of lineament pattern of the area from Landsat imagery, the trend of coastline, fractures, dykes, faults all suggest that the North-South direction roughly marks that structural grain of the area.

The extrusive and intrusive rocks of the area with their wide range of composition mark a significant and interesting departure from the monotonous tholeiite which characterises the bulk of the deccan traps. Though here too, tholeiites dominate, they are interlayered with mugearite, alkali-basalt (with nepheline in the norm), olivine basalt (hypersthene normative), trachyte, potassic sodi-potassic rhyolite and pitchstone. The intrusive phases include diorite, trachyte, syenite, granophyre and alkaline variants.

Thermal springs in the area are located at Sativali, Paduspada and Koknere. The temperature recorded from these hot springs are 58 °to 59 °C, 42 and 54 to 56°C respectively.

Geographically, Greater Mumbai is an island outside the mainland of Konkan in Maharashtra separated from the mainland by the narrow Thane creek and a somewhat wider harbour bay. At present, it covers the original island group of Mumbai, and most of the island of Salsette, with the former Trombay Island appended to it in its southeast. A small part in the north the Salsette Island, however, lies in thane district. The Salsette-Mumbai island creek and the thane creek together separate it from the mainland. Thus the area of greater Mumbai is surrounded on three sides by the seas, by the Arabian sea to the west and the south, the harbour bay and the thane creek in the east but in the north, the district of thane stretches along its boundary across the northern parts of Salsette. Its height is hardly 10 to 15m above sea level.

### **Geology of Project Area**

The alignment for the proposed road tunnel in Maharashtra between Borivali to Thane in southern Maharashtra situated in Sanjay Gandhi National.

The area comes under the National park known as Sanjay Gandhi National Park of Thane District in Maharashtra. National park serves as home for many wild animals and conserves its wildlife, flora and fauna. During the construction of the tunnel, there should be minimal disturbance to the habitat of wildlife therefore; tunnel would be constructed by TBM tunnelling method which will not cause any disturbance to the wildlife. Western portal of the tunnel is accessible through NH8 and further from Shiv Vallabh Road which will be finally reached to the portal via a proposed approach road. The main rock type comprising the tunnel will be Unclassified Basaltic 'Aa' FLOWS up to a length of approximately 7+300 m as per Geological Survey of India (GSI), Geological Quadrangle Map of Thane Fig.3 (scale 1:250,000) attached. After 'Aa' flows Agglomerate and Tuffs shall encounter for approximately another 1 km and again 'Aa' flows will encounter till the end of Eastern Portal. Eastern portal is connected to Pokharan Road 1 from a proposed Approach road and then further to NH 3.

A minor fault has been identified at an approximate chainage of 3+800 m with down throw which will encounter the tunnel at approx. Ch. 3+740 to 3+840. Fractured rock mass shall encounter at the vicinity of the fault at the tunnel grade. A river is crossing the alignment at Chainage 6+500 m where wet to dripping ground water conditions may encounter. The minimum and maximum overburden in the tunnel is 13 m to 300 m. Slope wash material of 3-5m could be found throughout the tunnel.

Rock expected to be encountered at the location of the tunnel will be hard, massive Basalt of Deccan Traps with uniaxial compressive strength varying from 100-200 MPa. During construction the tunnel will be mostly dry. The major joint is vertical joint set in this area which is closely spaced and can be seen prominently at western portal.

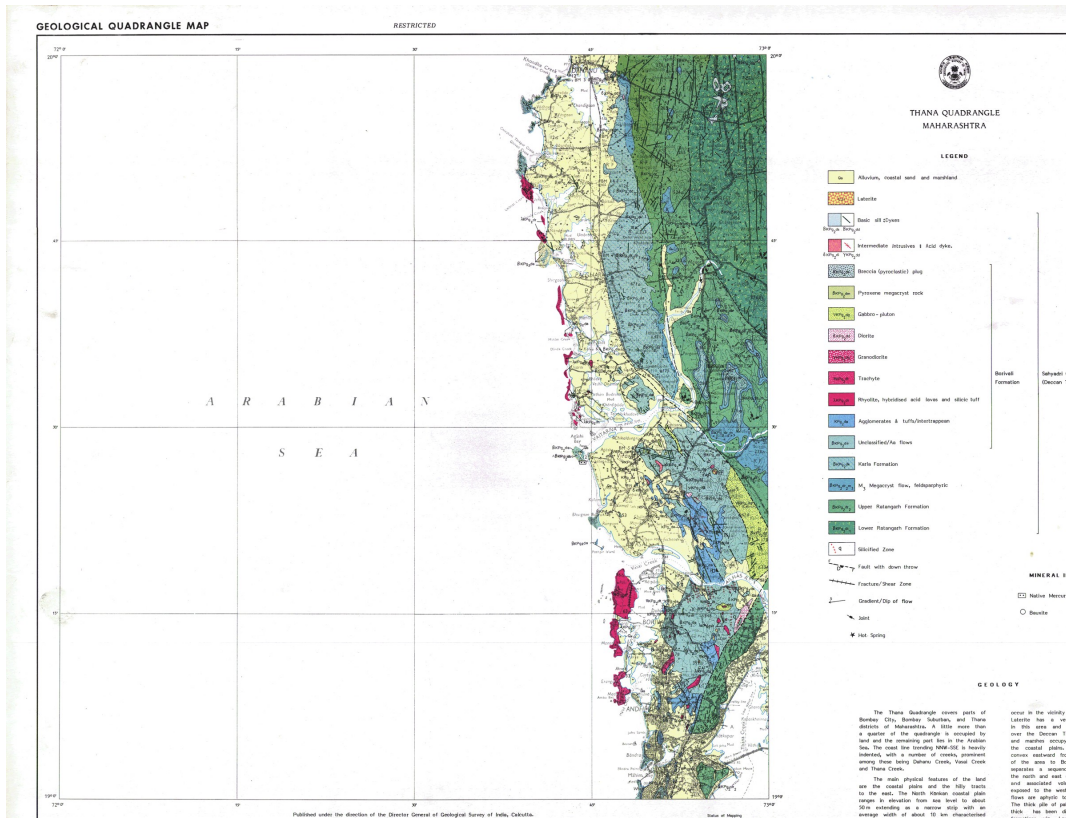

Figure: Geological Quadrangle Map of Thane area

### Seismicity of the project area

Mumbai lies very close to the seismically active zone and has been rated in Zone 3 (on a scale of 2 to 5, with 5 being the most prone to earthquakes) by the India Meteorological Department. Mumbai has experienced some moderate- and many low-intensity earthquakes in its history.

### Geology and Hydrogeological studies.

Geology and hydrogeological studies were also taken up to see the influence of tunnelling on ground water. The report for the same is annexed as annexure1.

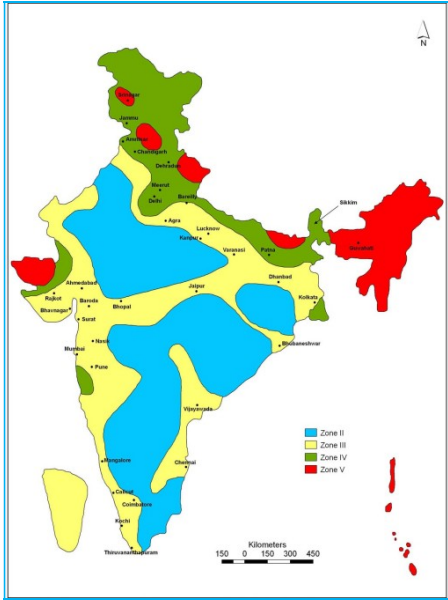

**Figure: Seismic Zonation map of India showing boxed Project location**

### 6.1 General layout

The tunnel shall have the same geometric standards as on the main carriageway outside the tunnel except as specified.

- Cross-section - Shape of tunnel cross-section shall be circular with the methodology of construction using TBM technology.
- Horizontal clearance- The twin tunnel shall cater for carriageway and space to be provided for ventilation system, escape footway, emergency lane, where necessary, lighting, drainage, fire and other services.
- Vertical clearance- The tunnel shall have a minimum vertical clearance of 5.50 m over the full width of carriageway and Emergency Lane.
- Additional vertical clearance shall be provided for accommodating tunnel lighting fixtures and other accessories
- Number of traffic lanes - Design service volume for tunnel shall be same as for the portion of highway outside the tunnel. Number of lanes to be provided shall be based on the traffic projections for 25 years Tunnels shall have minimum 2-lanes carriageway for each direction of traffic with an emergency lane to be used by rescue of emergency vehicles with a carriage way of height 5.5 meters
- Carriageway & Emergency lane - The carriageways of the tunnels shall be of cement concrete. Proper transitions, line of sight and informatory signs shall be ensured.

- Tunnel spacing- The clear distance between the twin tubes shall be kept minimum to 1 d and based on type of strata and structural stability of the tunnel, it can greater than 1d or above within the ROW of 41.5m.
- Tunnel Cross passages - The twin tunnels shall be connected by cross passages in line with the NFPA 502 & IRC: SP:84-2014 Annexure B1.
  - a) There shall be a pedestrian cross passage at a spacing of 300 meters and vehicle cross passages after every 2 pedestrian cross passages. As shown below:

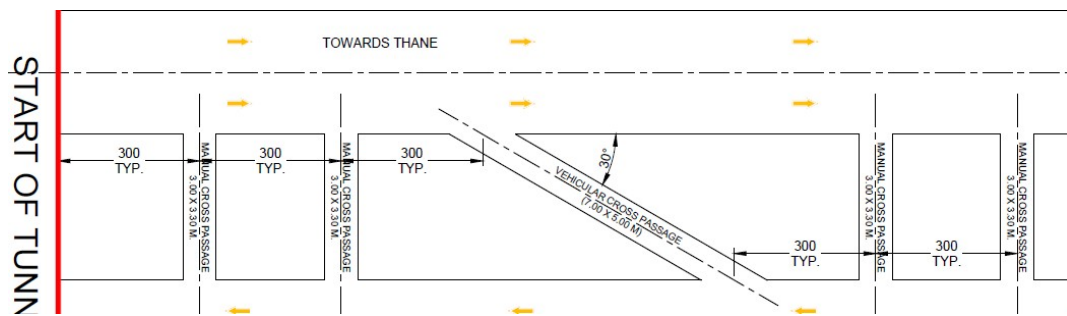

**Typical details of Pedestrian Cross passage spacing at 300m and vehicular cross passage after every two pedestrian cross passages**

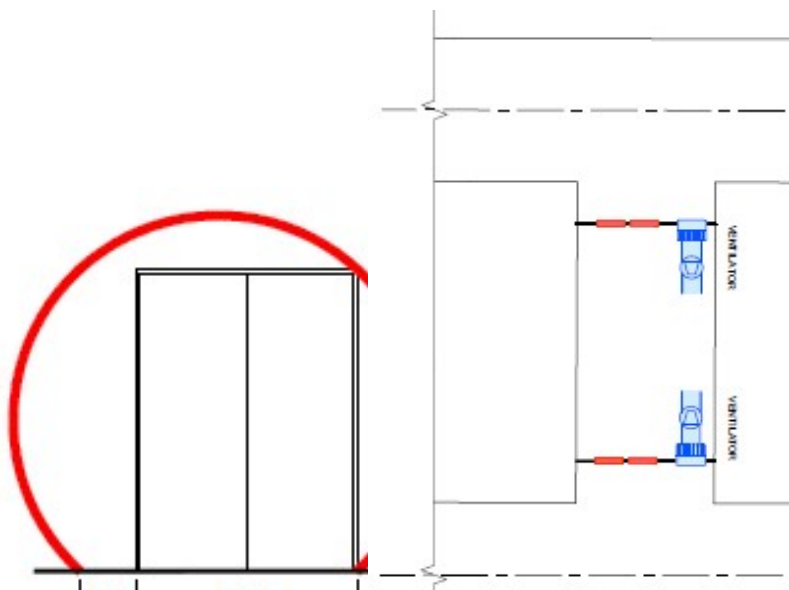

### Typical Section and Plan of Pedestrain Cross passage



### Ref: Cross Passage & Tunnel Doors - Booth Industries

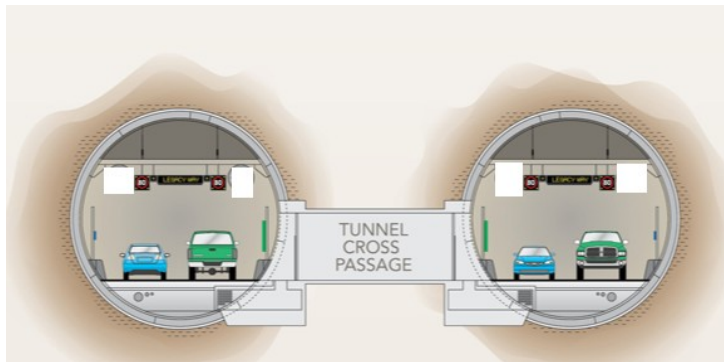

- b) The vehicle cross passage shall be at an angle of 30 degrees with the direction of flow of the traffic from one tube to other tube. And this shall be only used by emergency Vehicles/ Rescue to reach the event of an incident/accident spot. The vehicle cross passage shall have a provision of one traffic lane, edge strip of 0.60 m, crash barriers and walkways on either side.

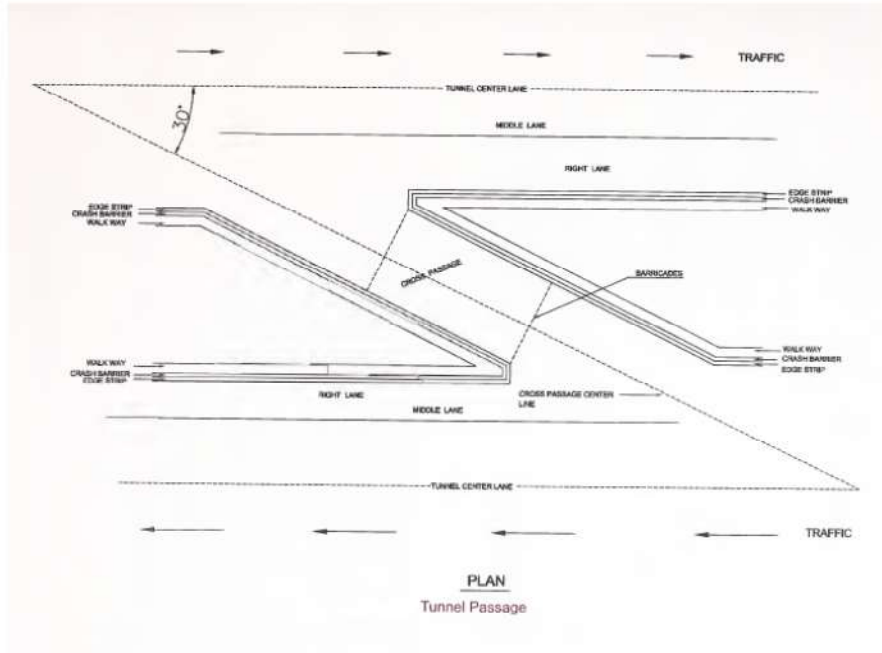

**Typical vehicle cross passage, Ref: IRC SP:84- 2014**

Although ,IRC SP:84-2014 specifies that in normal case these vehicle cross passages needs be barricaded however, for this project ,the vehicular cross passages be closed by means of fire-rated rolling shutter with an access control mechanism or some other type all the times and will be opened automatically from the control center in the event of fire/accident .This way, in the event of fire, the smoke will not enter the non-incident tunnel and the purpose of longitudinal ventilation is effective.

In an unfortunate event of tunnel fire, in one of the tunnels, the tunnels (including up and down traffic) should be closed at portals immediately to prevent general vehicles entering the tunnel. The other tunnel (Tunnel with non-incident) shall be used as rescue route for rescue / emergency vehicle . Pedestrian cross passages for every 300 m to be provided in line with the NFPA 502 with. The characteristics of cross-passage doors (reaction and resistance to fire, air tightness, thermal insulation, etc.) must be adapted to regulations in force and must be consistent with the fire resistance performance of the structure surrounding the door. Measures must be taken to ensure that in the event of fire, the smoke present in one tube does not spread to the other tube (airlock at each end of the cross-passage, which may be equipped with an over-pressure system).

- c) In addition, one of the pedestrian cross passage falling within the vicinity of the lowest point in the tunnel shall also be used as “Cross -Passage with sump”. As this is required to collect and pump out the water from the tunnel to outside sump for disposal after treatment of water.

- Vertical alignment - The vertical gradient shall not be more than 2.5 percent for tunnels of length more than 500 m. In short tunnels the gradient may be limited to 6 percent however, in such cases the ventilation system should be designed to take effect of gradient and possible incidence of fire.
- Horizontal alignment - The horizontal alignment shall be straight as far as practicable. However, measures shall be taken to overcome the effect of monotony. Similarly, last few metres of the tunnel shall have gentle curve. The curves if provided shall be gentle and meet the minimum radius requirements for design speed of the tunnel. Tunnel alignment at the ends and open/approach cuts shall merge smoothly with adjoining road in the open air. The crossing of central median shall be provided at suitable locations at approaches of both tunnel tubes so as to allow emergency services gain immediate access to either tube and also to send back diverted traffic to proper traffic lanes

Tunnel geometry /Selection of Tunnel Category

As per IRC: SP : 84-2014 Manual of Specifications the category of tunnels fall into AA as the length of tunnel is 10.25 km and the traffic volume is greater than 40,000 .

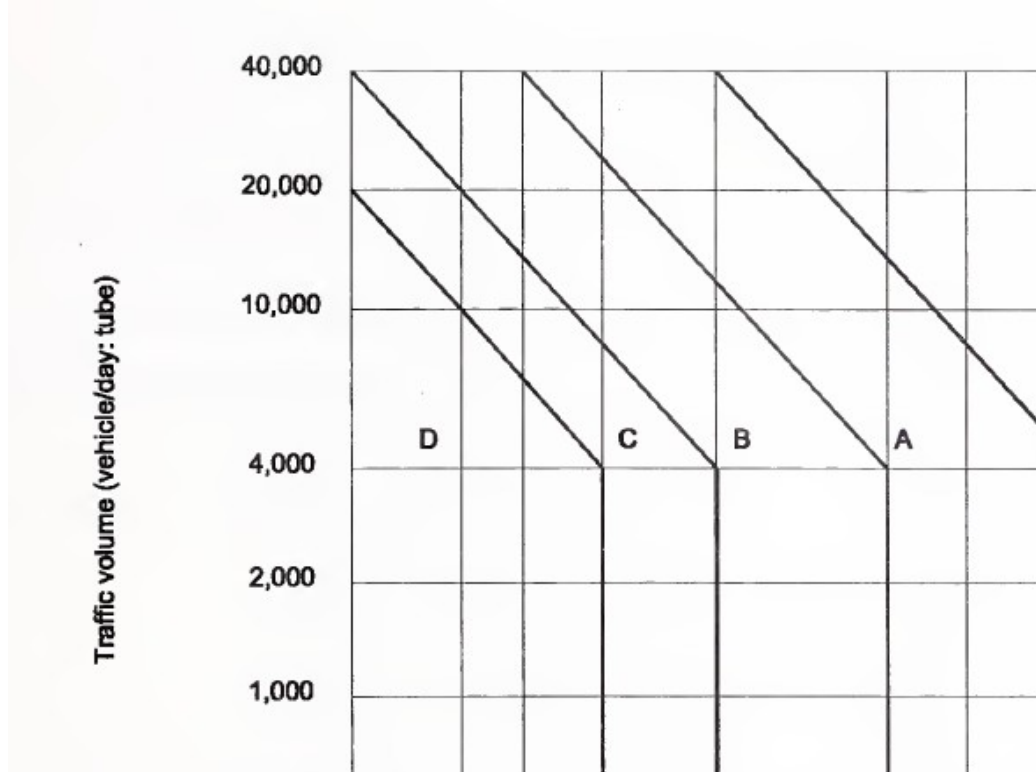

Ref: IRC: SP: 84-2014 Manual of Specifications

Similarly considering the Road tunnel Manual from Norwegian Public Roads Administration, the category of tunnels falls into “F” as these are twin tube tunnels with a length of 10.25 kms and Annual Average Daily Traffic (Chapter 4: Traffic Surveys Forecast and Assignment ,4.6 Data Analysis,4.6.1 Traffic volume of this documents) is more than 44000

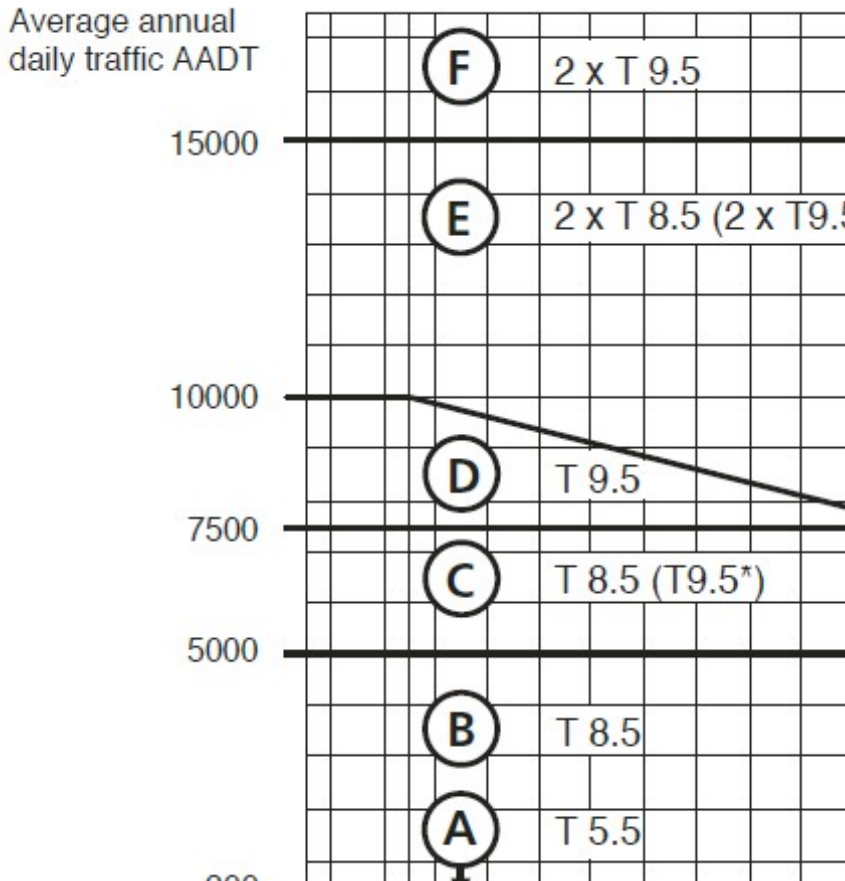

Ref: Road Tunnels (Norwegian Public Roads Administration)

**Conclusions:** Considering the above guidelines, this geometry of two tunnels of 2-lanes + an emergency lane complies to the standards.

**Tunnel Approach**

Tunnel approach shall have smoothly aligned tunnel walls without any sudden narrowing to avoid a shift from the tunnel wall and a good day/night visibility of the edge lines. Tunnel wall lining shall be of white color with high luminous reflectance.

**Tunnel Portal**

Tunnel portals should, apart from providing protection at entry and exit, convey drivers about the presence of the tunnel reduce the luminance of facing walls and be in harmony with the surrounding environment from aesthetics considerations.

## Design of Drainage System

Efficient and effective drainage system shall be provided in the tunnel for the removal of water from rainfall, seepage, tunnel washing operations, vehicle drippings/spillage on firefighting operations.

In order to trap rainwater from hill slopes and prevent it from flowing into the approach cuts and the tunnel, suitable catch water drains shall be provided above the top of sides of the open/approach cuts and above excavated portals. In the open/approach cuts discontinuous kerbs shall be provided to demarcate the edge of the carriageway. Beyond the kerbs, side drains with adequate waterway shall be provided in the open/approach cuts.

Inside the tunnel, suitable side drains shall be provided at the edges /kerbs. Suitable drainpipes going through the kerbs shall be provided to lead seepage and wash water to the drains. The drains shall be located on either side of the carriage ways. The carriageway shall have suitable camber to facilitate drainage into the side drains. As these are uni-directional tunnel the camber shall be from high speed lane towards low speed lane. The vertical profile is normally kept so that to facilitate self-draining of tunnel by providing high point somewhere in the tunnel combination of self-draining and pumping arrangements.

The black topped road surface inside tunnel, generally constructed on rocky subgrade, gets damaged due to seepage water and creates severe problem for surface drainage. Hence the pavement inside the tunnel and in approach cuts shall be of high-performance pavement concrete.

### 6.2 Assessment of vibration generated by TBM method of tunneling

During the planning of new infrastructure projects, preparation of a robust environmental impact statement is essential to ensure the acceptability of the scheme. Tunnels are beneficial in minimising many of the impacts normally associated with linear projects, but there is a potential for ground borne noise and vibration (GBN&V) to affect people, properties and wildlife above the entire tunnel corridor albeit small. Drawing on recent experience from planning and construction of infrastructure tunnels largely in India together with published information from elsewhere, assessment of vibration and ground borne noise during tunnel construction has been done. The focus is on bored tunnels constructed by tunnel boring machines (TBMs), and those works connected with ancillary construction beneath the ground.



### Route Conditions

The Western portal (Borivilli end) of the twin 10.2 km bored tunnel is accessible through NH8 and further from Shiv Vallabh Road which will be finally reached to the portal via a proposed approach road. The Eastern portal is connected to Pokharan Road 1 from a proposed Approach road and then further to NH 3.

Ground conditions in the tunnels beneath the Sanjay Gandhi National Park will include hard, massive Basalt of Deccan Traps with uniaxial compressive strength varying from 100-200 MPa. During construction the tunnel will be mostly dry. At western portal weathered rock has been identified during site visit. The major joint is vertical joint set in this area which is closely spaced and can be seen prominently at western portal. Toppling failure may occur as joints are closely spaced to each other. The minimum and maximum overburden in the tunnel is 13m to 291m (from tunnel top to the surface). Slope wash material of 3-5m could be found throughout the tunnel. A section through the ground conditions is shown below.

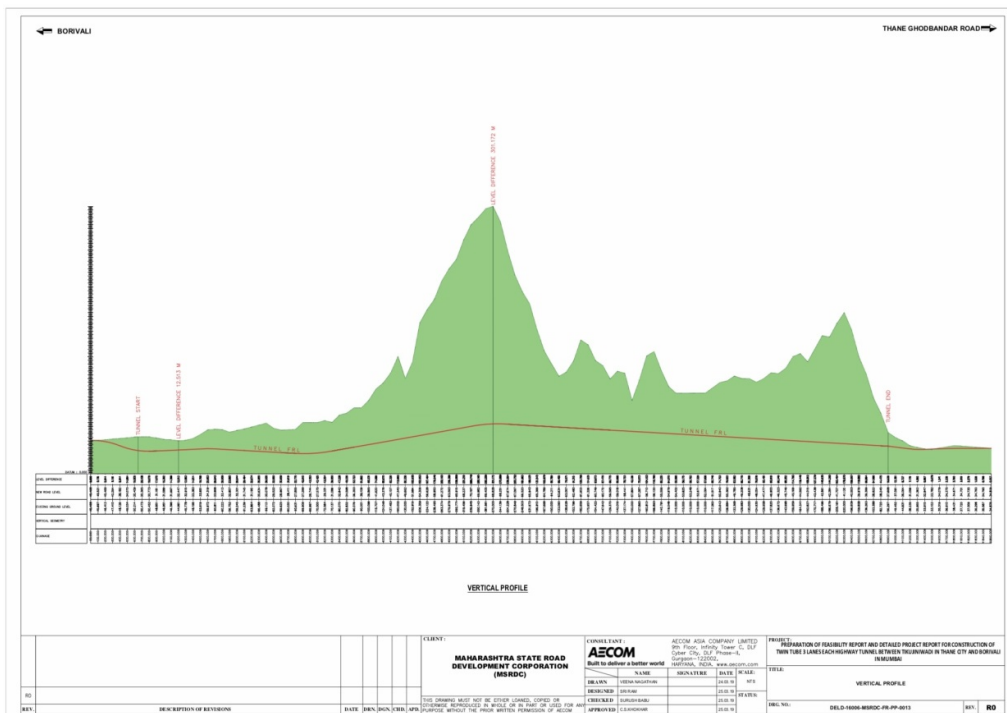

Construction vibration can be caused by the operation of TBMs, and the excavation of connections between the tunnels. For the purpose of this study, the vibration from each source is considered separately.

The UK, Transport Research Laboratory Report 429 (Hiller and Crabb, 2000) provides a simple empirical equation based on distance from the source, but with a note that the vibration is dependent on geology

### Ground borne Noise & Vibration from the Tunnel Boring Machines

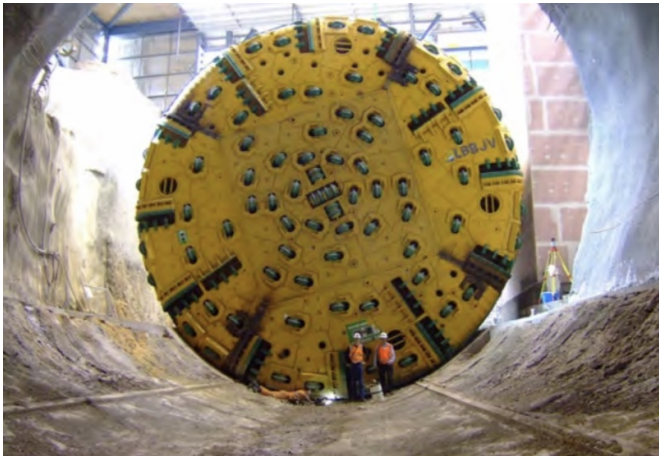

The tunnels would be bored through dense rock, hard, massive Basalt of Deccan Traps with uniaxial compressive strength varying from 100-200 MPa which can transmit vibration. The vibration diminishes with distance and is generally not detectable at more than 48m. The tunnel will vary in depth from 13m to 291m so the area where vibration under Sanjay Gandhi National Park would be felt is limited. The TBMs are expected to advance at a rate of about 10m per day, which means the vibration source will move rapidly away from any given location not affecting the wildlife in the

National Park. From the consolidated vertical tunnel section of Sanjay Gandhi National Park (SGNP), it is clear that the point from which the tunnel depth exceeds 48m below GL is outside the core zone of SGNP and hence no wildlife movement / activity is envisaged.

A minimum of 2 TBMs to be used to build the 13.05 meters twin road tunnels. The TBMs will be approximately 148 m (486 feet) long with an excess total weight of 1000 tonnes. The cutters heads will have a rotation speed of up to 3.2 rotations per minute and an applied nominal thrust force of approximately 58,000 KN (the equivalent force needed to lift 2,900 London taxis).

Vibration and ground borne noise are different aspects of the same phenomenon. Vibration is oscillating movement of the ground or other solid material. This may cause sound to be radiated from vibrating surfaces into either air or water. Vibration, if high enough in amplitude, may be perceived by the tactile sense. Re-radiated ground borne, or structure borne noise is perceived by the sense of hearing at frequencies within audible range. Vibration may be perceived at frequencies too low to be audible.

The factors which influence the generation and propagation of vibration and ground borne noise from TBMs are primarily the amount of energy required to cut the soil (or rock in the case of Thane -Borivali tunnel) and the propagation characteristics of the soil/rock. Rotational speed, cutter head type and face pressure have a much similar effect. The energy requirement is a function of the tunnel diameter and the operating characteristics of the machine.

There are two major dynamic excitation sources inside the TBM – the cutter force and the supporting forces. The cutter force is the dynamic impulsive forces acting on the excavation face by the cutter discs.

The supporting force is acted by the hydraulic cylinders on a supporting structure, in order to provide the thrusting pressure to push the TBM forward. The supporting structure depends on the Single Shield or double shield tunnel boring machine this support is provided by the completed rings embedded behind the

TBM as it advances or by using side stabilizers(grippers).Both of these forces occur when the TBM is advancing forward (referred to as the ‘shove’ phase), however during the overall build cycle, once the TBM has advanced forward one ring width, approximately 1.5 metres, the TBM ,depending on ground conditions and fractured zones, either will continue shoving during ring building using grippers as stabilizers or At this point (referred to as the ‘build’ cycle), pre-cast concrete tunnel segments are inserted and bolted together within the rear section of the TBM shield while the TBM is stationary. While the ring building is in progress jacks stop pushing and the cutting head stops rotating. Once in ring is in place, the hydraulic cylinders engage the newly constructed ring and the TBM recommences tunnelling forward and the cycle is repeated.

TBM GBN&V is sensitive to various parameters, including the distance to the cutting face, geology at the cutting face, geology along the transmission path, TBM type, thrusting pressure, rotational speed, cutter disc arrangement, etc. All of which can be controlled by the operator and manufacturer.



### Vibration from Cross Passages

Once the TBM work is complete, cross-passages will be constructed at specified intervals. The cross passages would be dug using Micro tunnelling equipment. Being this a Wildlife and national park, the permission for carrying out NATM by drill and blast construction is restricted.

### Mumbai Metro Line 3 (MML3)

controlled Drill and Blast Monitoring Records (NATM Tunnel UP Line) attached to the Anx2 to this report show that the Particle Parts Velocity (PPV) are consistently within acceptable limits set out in the Employers requirements attached. It is clear that at a depth of 20 to 25 meters the Limiting Construction-Induced Vibrations at adjacent structures do not exceed the maximum allowable.

### Impacts of Operational Vibration and Ground-Borne Noise

The Federal Transit Administration (FTA) has developed Impact Criteria which are used to estimate ground-borne noise and vibration levels that are expected to result in human annoyance for frequent events.

- Typical background vibration in residential areas rarely exceeds 50 velocity decibels (VdB).
- Humans can sense vibration at approximately 65 VdB.
- Areas within approximately 500 feet of the proposed alignment may experience vibration levels just approaching the level of human perception at 65 VdB. A smaller area immediately adjacent to

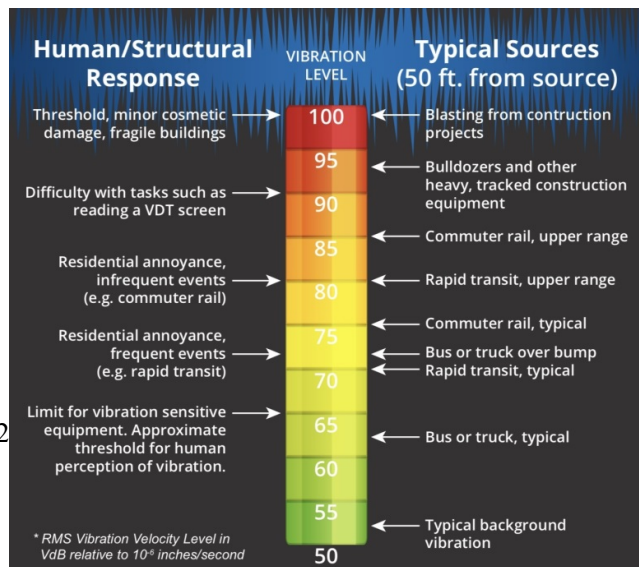

the proposed south portal approaches and existing Northeast Corridor tracks may experience vibration levels between 65 and 72 VdB, which is slightly perceptible to humans. No vibration impacts exceeding FTA Impact Criteria of 72 VdB would occur.

- An estimated 449 ground-borne noise impacts above the FTA Impact Criteria would occur. Mitigation measures will be incorporated into the final design to reduce these impacts.
- No vibration levels high enough to damage fragile buildings are estimated from operations.

#### 6.4 Conclusions

Potential ground borne noise and vibration sources during the construction phase have been identified. The major activities inducing potential ground borne noise and vibration impacts are from the operation of TBM and operational equipment in the tunnel.

Recent monitoring of results from MML3 tunnelling in Basalt grade 3 and 4 rock with a 6.68m diameter Dual mode TBM passing underneath installed sensors at depths of 21m to top of tunnel indicated no appreciable Ground borne noise or vibration on the closest sensitive receiver, and predicted results 5 Vdb were less than half, 2.54Vdb. These results are important, as they are under urban dwellings where complaints would be higher, there were none. In other words, all the monitoring receivers along the alignment behaved better than expected with results in line with that predicted.

The TBMs did not generate significant or adverse Ground borne noise or vibration impacts and very few complaints were received.

The conclusion reached from the tunnelling data in TRL 429, 'Ground borne vibration from mechanised construction works', was that it is the ground being excavated, rather than the excavation method or bore size that dictates the magnitude of vibration quantified.

TBM GBN&V is sensitive to various parameters, including the distance to the cutting face, geology at the cutting face, geology along the transmission path, TBM type, thrusting pressure, rotational speed, cutter disc arrangement, etc. all of which can be controlled by the operator and manufacturer.

Where controlled NATM Event blasting has been monitored on MML 3 sites, records show consistently the Limiting Construction-Induced Vibrations (PPV) at adjacent structures has not exceeded the maximum allowable.

From the consolidated vertical tunnel section of Sanjay Gandhi National Park (SGNP), it is clear that the point from which the tunnel depth exceeds 48m below GL is outside the core zone of SGNP and Drill and Blast would have no adverse effects is envisaged on the wildlife movement / activity.

## 6.5 Bored tunneling

Tunnelling by drill and blast / NATM was ruled out after discussions with forest department and MMRDA. So only bored tunnelling through TBM is being discussed. Moreover, the progress by TBM shall be more than that of NATM. With NATM we can work from both the faces in each tunnel and shall finish the project in 5.5 years Fig 15. Whereas with TBM the construction time shall be 4ys and 5 months fig16.

Bored tunnelling by using a Tunnel Boring Machine (TBM) is often used for excavation long tunnels. TBM technique has high potential and versatility tunnel drive by altering the physical size and strength of Tunnelling machines to match the wider range of rock hardness and geologically difficult conditions.

An effective TBM method requires the selection of appropriate equipment for different rock mass and geological conditions. The TBM may be suitable for excavating tunnels which contain competent rocks that can provide adequate geological stability for boring a long section tunnel without structural support

The process for bored tunnelling involves all or some of the following operations:

- i. Probe drilling (when needed)
- ii. Grouting (when needed)
- iii. Excavation
- iv. Supporting
- v. Transportation of muck
- vi. Lining or coating/sealing
- vii. Draining
- viii. Ventilation

Schedule of construction using TBM

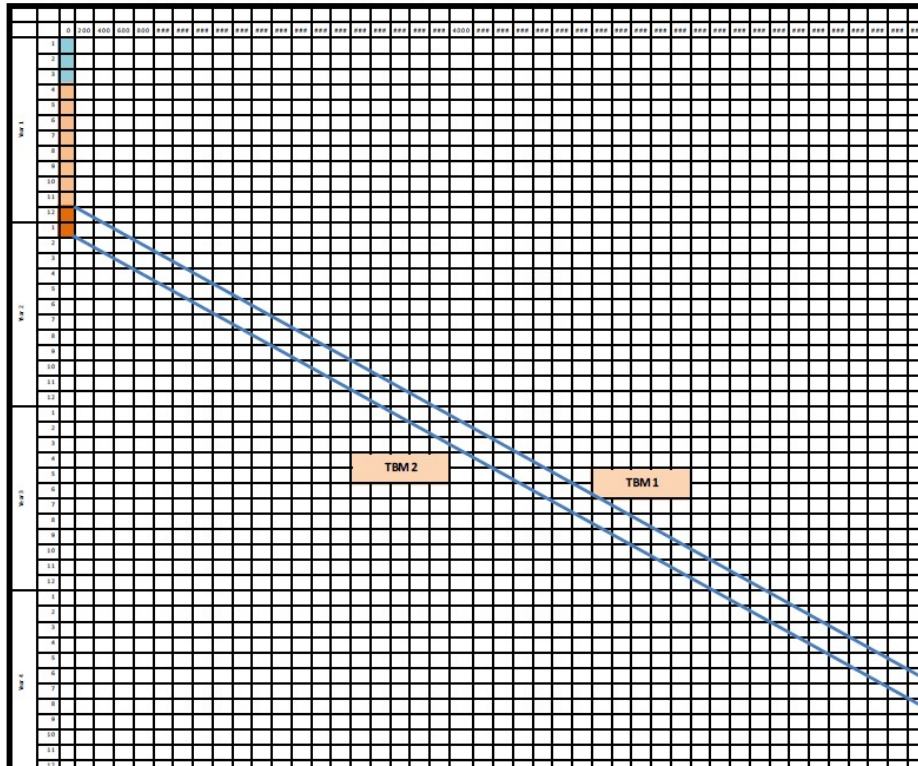

xiii.

xiv. Fig 16: showing construction schedule with TBM.

### 6.6 Advantages of Tunnel Boring Machine (TBM)

Following are the technical advantages of tunnelling by tunnel boring machines:

- i. Potential environmental impacts in terms of noise, dust, vibration and visual on sensitive receives are significantly reduced and are restricted to those located near the launching and retrieval areas;
- ii. With different work procedures taking place at the same time including excavation and installation of permanent pre-cast segments in tunnel; TBM is highly efficient.
- iii. Risk of settlement will be greatly reduced, and loss or movement of the underground water table will be avoided, minimizing impact on the nearby structure.

### 6.7 Selection of TBM

A TBM is a complex system with a main body and other supporting elements to be made up of mechanisms for cutting, shoving, steering, gripping, shielding, exploratory drilling, ground control and support, lining erection, spoil (muck) removal, ventilation and power supply. Figure below shows different types of TBMs.

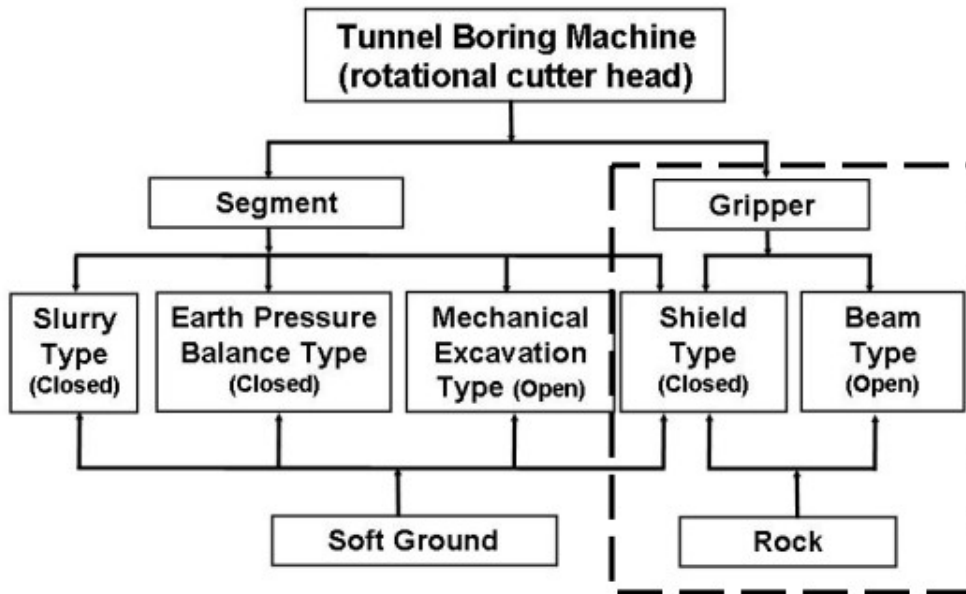

**Figure 9: Classification of Tunnel Excavation Machines**

Factors governing in selection of TBM tunnelling are:

- A. Depth of cover/overstressing** - One of the key considerations for the use of TBMs is the depth of rock cover along the tunnel alignment and the potential for overstressing. Overstressing will occur under the following conditions:
- xv. High rock cover.
  - xvi. Low/moderate rock strength.
  - xvii. High in situ stresses.
- B. Site access and terrain-** Appropriate site access and terrain with low-gradient roads must be considered to allow for the practical mobilization of TBM equipment
- C. TBM launching requirements-** Practical locations with sufficient area must exist that facilitate the assembly of TBMs,
- D. Tunnel alignment and inclination** - The vertical alignment for TBMs is typically kept below a maximum grade of 3%; otherwise, special braking systems have to be included. Horizontal alignments also have similar limitations, with typical minimum radii of curvature of about 250-300 m

- E. Contractor experience** - Experience with the use of TBMs is a key requirement for successful tunnel construction. The selection of a TBM contractor should be based on a pre-qualification process, whereby previous experience with similar size tunnels and similar geological environments should be part of the evaluation criteria.
- F. Project schedule and procurement-** Early or on-time completion is nowhere more vital than for major underground projects at the start-up of operations. These projects may mandate the use of TBMs in order to provide an overall shorter construction schedule.
- G. Logistics-** The main logistics to consider for the use of TBMs at sites is the availability of power/electrical supply. Power requirements for TBMs vary with size.

### 6.8 Different types of TBMs

#### Hard Rock TBM's

As shown in the figure above tunnel boring machines (TBM) suitable for rock tunnelling nowadays are full-face, rotational (types of cutter head) excavation machines and can be generally classified into two general categories: Gripper and Segment based on the machine reaction force.

- xviii. Open Gripper Main Beam TBM (Open Gripper Type)
- xix. Single Shield TBM (Closed Segment-Shield Type)
- xx. Double Shield TBM (Closed Gripper/Segment-Shield Type)
- xxi. Earth Pressure Balance Machine
- xxii. Slurry Face Machine (SFM)

#### Open Gripper Main Beam TBM

The open gripper-beam category of TBMs is suited for stable to friable rock with occasional fractured zones and controllable groundwater inflows. Figures below (Robbins) illustrates a typical diagram of a modern open gripper main beam TBM and highlights the major components including:

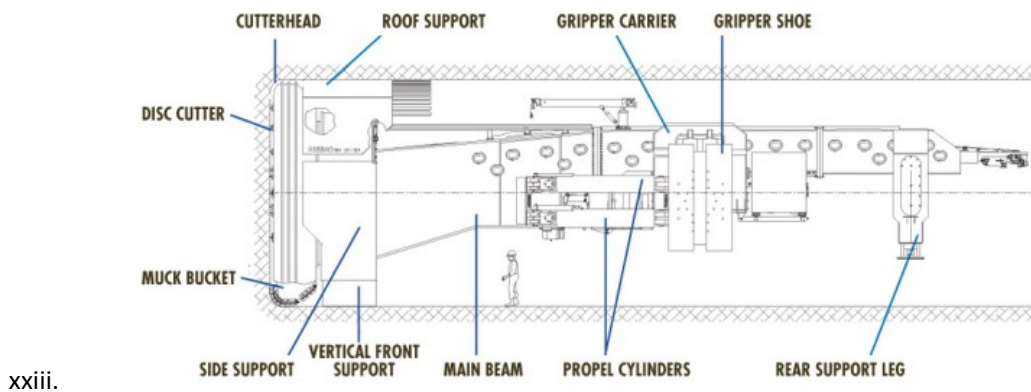
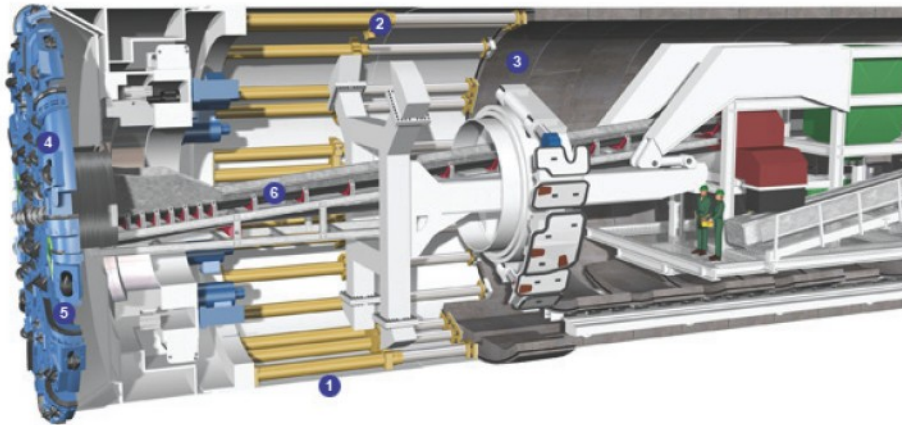

**Figure 10: Typical Diagram for Open Gripper Main Beam TBM (Robbins)**

Open-type TBMs have no shield, leaving the area behind the cutter head open for rock support. TBM does not install concrete segments behind it as other machines do. Instead, the rock is held up using ground support methods such as ring beams, rock bolts, shotcrete, steel straps, ring steel and wire mesh. This type of TBM is generally not preferable for urban regions.

**Single Shield TBM (Closed Segment-Shield Type)**

As shown in Figure below, the Single Shield TBMs are fitted with an open shield (unpressurized face) to cope with more brittle rock formations or soft rock. The TBM is protected by the shield (1) and extended and driven forward by means of hydraulic thrust cylinders (2) on the last completed segment ring (3). The rotating cutterhead (4) is fitted with hard rock disk cutters, which roll across the tunnel face, cutting notches in it, and subsequently dislodging large chips of rock (Figure below). Muck bucket (5), which are positioned at some distance behind the disks, carry the dislodged rock pieces behind the cutterhead. The excavated material is brought to the surface by conveyers (6).



Notes:

(1) Shield; (2) thrust cylinders; (3) segmental lining; (4) cutterhead; (5) muck bucket; and (6) conveyers

**Figure 11: Typical Diagram of Single Shield TBM (Herrenknecht)**

**Double Shielded TBM**

A Double Shield TBM (Figure below) consists of a rotating cutter head mounted to the cutter head support, followed by three shields: a telescopic shield (a smaller diameter inner shield which slides within the larger outer shield), a gripper shield and a tail shield.

In fractured rock, shielded hard rock TBMs can be used, which erect concrete segments to support unstable tunnel walls behind the machine. Double Shield TBMs have two modes; in stable ground they can grip against the tunnel walls to advance. In unstable, fractured ground, the thrust is shifted to thrust cylinders that push off against the tunnel segments behind the machine. This keeps the significant thrust forces from impacting fragile tunnel walls. Single Shield TBMs operate in the same way, but are used only in fractured ground, as they can only push off against the concrete segments.

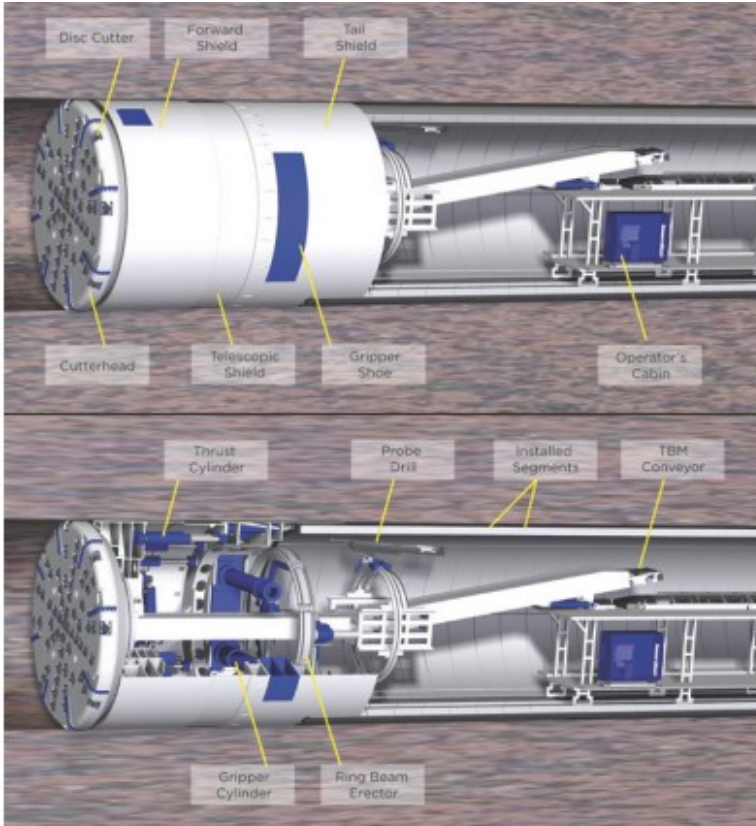
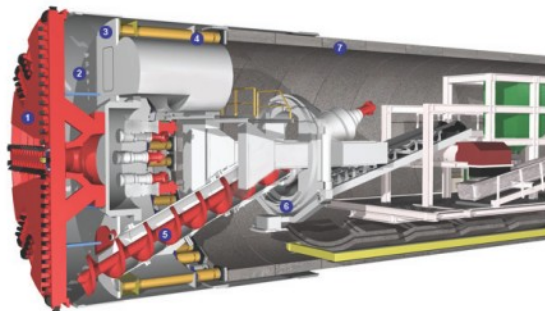

**Figure 12: Typical Diagram for Double Shield TBM (Robbins)**

xxiv.

**Earth Pressure Balance Machine**

Earth pressure balance machines (EPB) (Figure below) are pressurized face shield machines specially designed for operation in the ground and has a high percentage of fines both of which will assist the formation of a plug in the screw conveyor and will control groundwater inflows.



Notes:

- (1) Cutterhead; (2) excavation chamber; (3) bulkhead; (4) thrust cylinders; (5) screw conveyor; (6) segment erector; and (7) Segmental Lining

**Figure 13: Overview of Earth Pressure Balance Machine (EPB)**

The EPB machine continuously supports to the tunnel face by balancing the inside earth and water pressure against the thrust pressure of the machine. The working area inside the EPB machine is completely sealed against the fluid pressure of the ground outside the machine.

### Slurry Face Machine

Slurry face machine (SFM) are pressurized face shield machines specially designed for tunnelling especially where the ground is loose water bearing that are easily separated from the slurry at the separation plant. The SFM provides stability at the face hydraulically by bentonite slurry kept under pressure to counteract the native earth and groundwater pressure, and to prevent an uncontrolled penetration of soil or a loss of stability at the tunnel face.

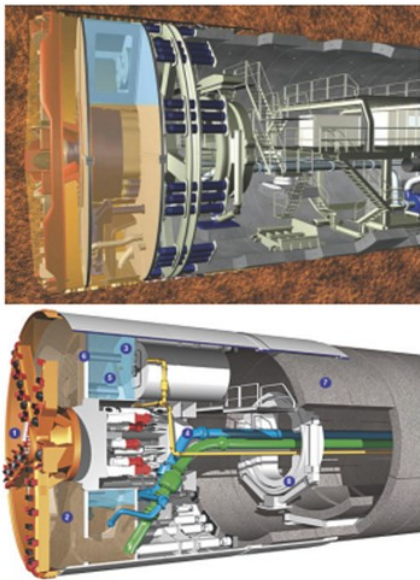

Notes:  
 (1) Cutterhead; (2) excavation chamber; (3) bulkhead; (4) slurry feed line; (5) air cushion; (6) wall; (7) Segmental Lining; and (8) segment erector

**Figure 14: Overview of Slurry Face Machine (SFM) (Herrenknecht's Mixshield Machines)**

### Conclusion

Keeping in view the decision by forest department and discussions with MMRDA to use TBM for this tunnel, appropriate TBM is discussed.

Considering the geology, permeability of ground and the length of the tunnels, the preferable machine suited for the project will be a Single-shield type or Double shield type machine supported by the precast segmental lining rings. These types of machines have achieved good advance rates in the similar geological conditions. The EPBs and SFMs would not be a good option for the project as advance rates of these machines are comparatively low in such geological conditions. These types of machines are usually preferred in urban tunnelling.

Contractor shall be solely responsible for the selection, design and supply of a tunnel boring machine and auxiliary equipment and for the design and execution of the reinforced concrete precast segmental lining

system compatible complying with the characteristics of the TBM. The design work shall be submitted for approval the tunnel boring machine (TBM) shall comply with the requirements of the country of manufacture.

The machine shall be new and will be compatible for all of the types of basaltic rock as specified in the geological sections. During construction, the Contractor shall enable and assist the Supervisor and his representatives to reach the tunnelling machine with all of its various components at any time that he deems fit and shall assist him in all matters related to inspection and verification of the tunnel alignment including independent survey of the work of the Contractor's surveyor and the performance of geological mapping of the rock as actually exposed. Such assistance shall be included in the Contractor's work and will not be paid for separately.

### **Cross section of the tunnels**

The cross section of tunnel is very important aspect of tunnel design. The main objective of road tunnel is to ensure least disturbances to the environment and ensure safe transit of traffic for which the facility is designed at least cost. The cross section and the finished width of the tunnel is a very important aspect and depends upon the number of lanes, projected traffic volume, provision of ventilation system and provision of pedestrian traffic.

Keeping in view the traffic type and forecast it has been proposed to have twin tube three lane each highway tunnel. As per IRC: SP: 84-2014, typical cross section for three lane tunnel excavation type construction is proposed as shown below:

In case of twin tube tunnels, each tunnel tube with unidirectional traffic, tunnel will be connected at fixed distances of about 500m through cross passages vehicular and 300m through cross passages pedestrian. There is provision of lay-byes at every 750m to park at least 6 vehicles along the length of tunnel with one lane width. The clear distance between the two tubes shall be kept depending upon the type of strata and structural stability. A road tunnel cross section must be able to accommodate the horizontal and vertical traffic clearances, as well as the other required elements. The typical cross section elements include:

- Travel lanes
- Shoulders
- Sidewalks/Curbs
- Tunnel drainage
- Tunnel ventilation
- Tunnel lighting
- Tunnel utilities and power
- Water supply pipes for firefighting
- Cabinets for hose reels and fire extinguishers
- Signals and signs above roadway lanes
- CCTV surveillance cameras
- Emergency telephones

- fire and safety protection
- Communication antennae/equipment
- Monitoring equipment of noxious emissions and visibility
- Emergency egress illuminated signs at low level (so that they are visible in case of a fire or smoke condition)

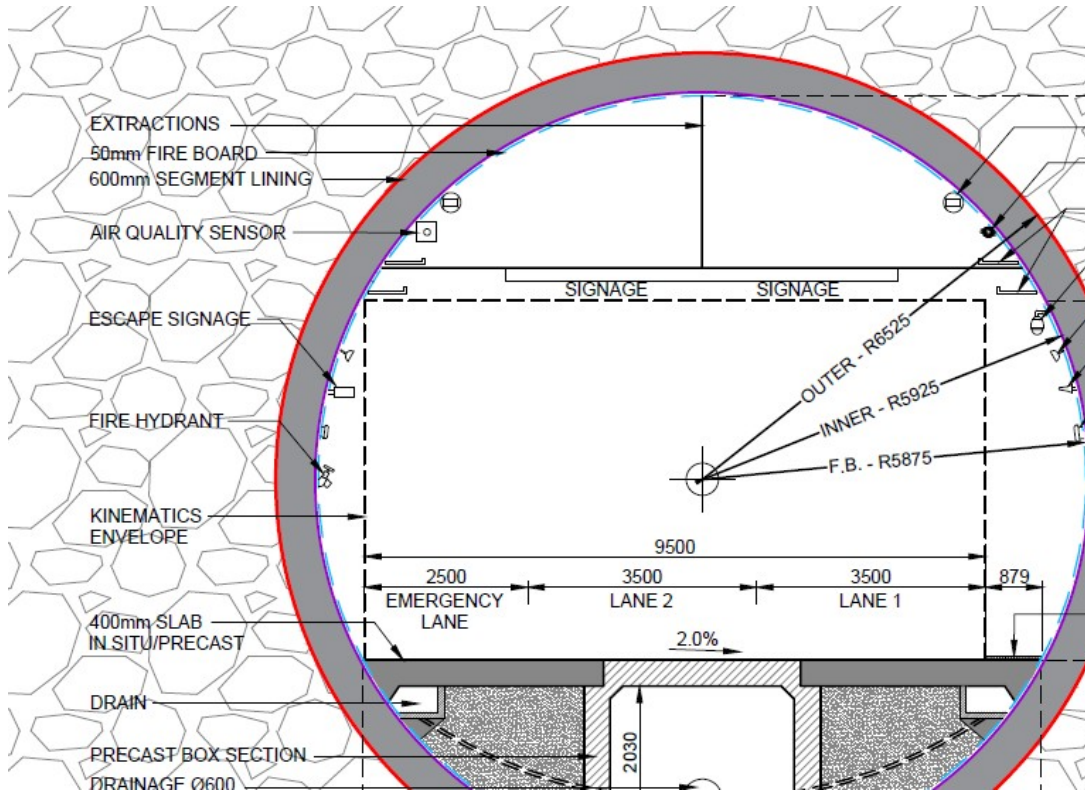
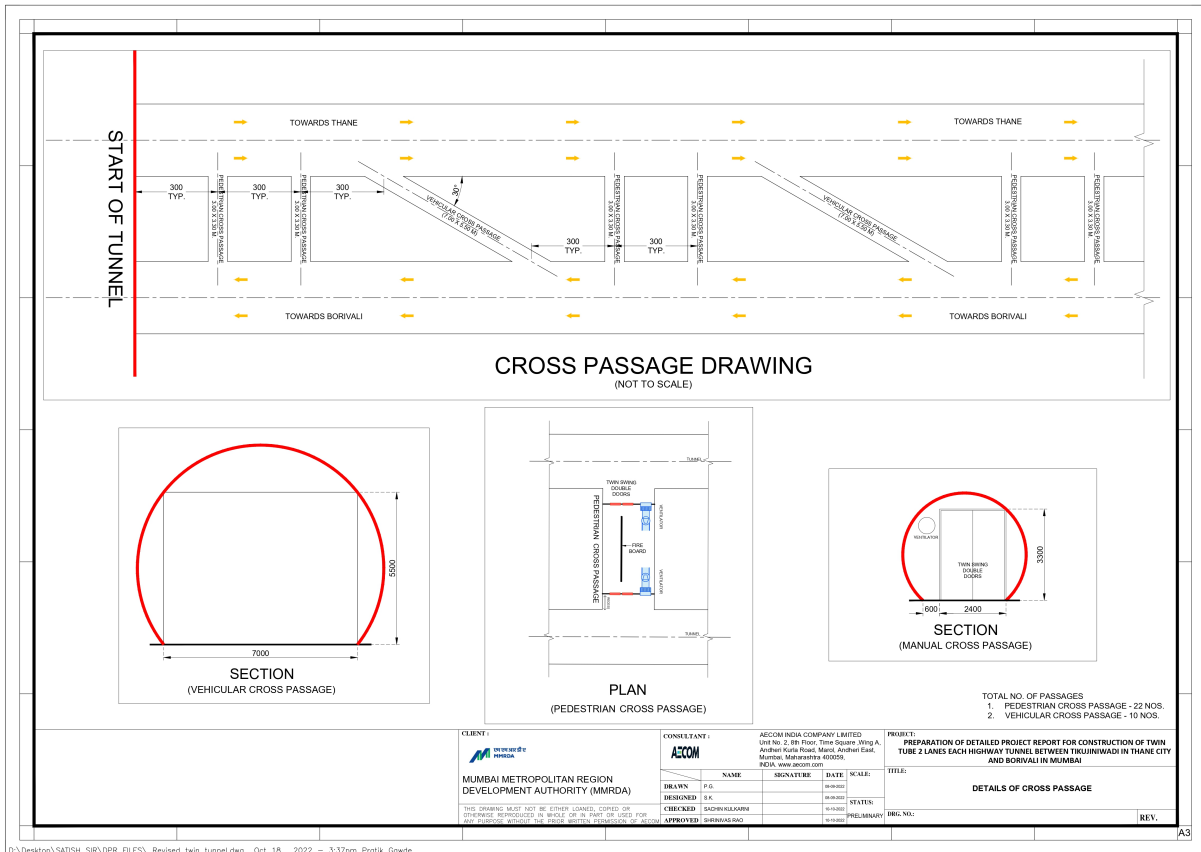

**Figure 15: Preferred Cross Section of the TBM Tunnel**

### Interconnections

As per IRC SP 91, in case of double tube tunnels, the interconnections as cross passages shall be provided at every 300 m of intervals. At the same time, as per NFPA 502, the interconnections for cross passages shall be provided at every 300 m of intervals.

These should be used in the event of an incident/ accident in one of the tubes, the other tube shall be used as a rescue route.



### 6.9 Tunnel Excavation – Mucking method selection

#### Mucking method selection approach

Mucking, i.e. the gathering and transportation of material where it has been deposited after extraction, loading, hauling and disposal is a key activity in the tunnel excavation process and is crucial to achieve the desired tunnel excavation advance rate and/or the desired total project advance rate.

The success of the construction of a tunnel not only depends on the performance of TBM, but also on the most efficient system to evacuate the spoil excavated by the TBM out of the tunnel. Disruption in the evacuation works very often leads to the TBM boring availability and subsequently, stoppage of the overall production of the project.

As the length of these tunnels are 10.25 m and using rail mounted locomotives/Muck cars as muck hauling units will result in considerable delays in a cycle of “Excavation – Ring build”. Muck hauling using “High speed belt conveyor system” is a preferred choice

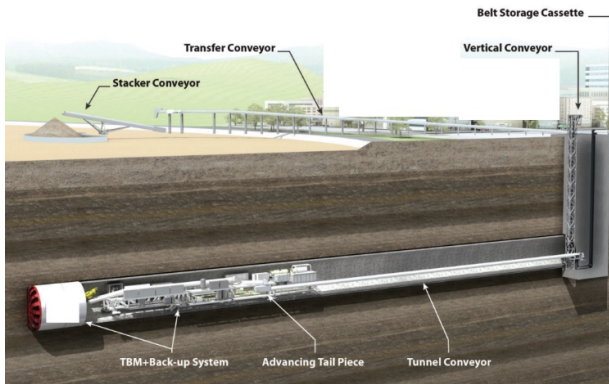

Fig.10



Fig :11

Courtesy:

Fig 10 Mucking from TBM with belt conveyor: <https://TERRATEC-Conveyor>

Fig 11: <https://www.robbinstbm.com/products/conveyors/vertical/>

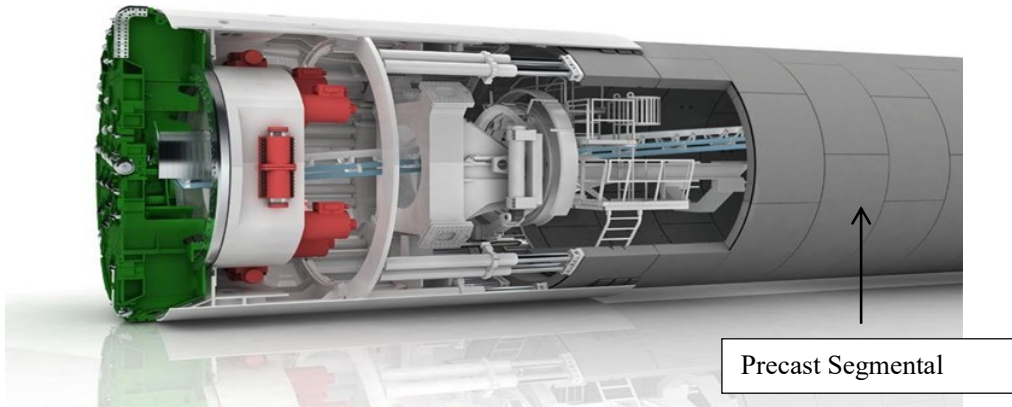

Fig: 12 <https://www.herrenknecht.com/en/products/productdetail/belt-conveyor-systems/>

## 6.10 Tunnel Lining

### Precast Segmental Lining

The Single Shield TBM uses the segmental lining to advance in the ground. The rings are built under the protection of the steel shield which eliminates the risk of collapsing ground. Water inflows can be reduced to a controllable measure thanks to the injection body which is built up in front of the tunnel face using injection drills through the shield.



The suitable option for the segmental lining ring will be a universal segmental ring. The preferred configuration of the ring is considered as 7+1 and will consist of 7 segments plus 1 key (1 no. x 20°, 1 no. x 55°, 6 nos. x 48°). The proposed thickness of the segment is 600 mm however, the exact thickness, ring configuration and tapering can only be evaluated during detailed design by the contractor.

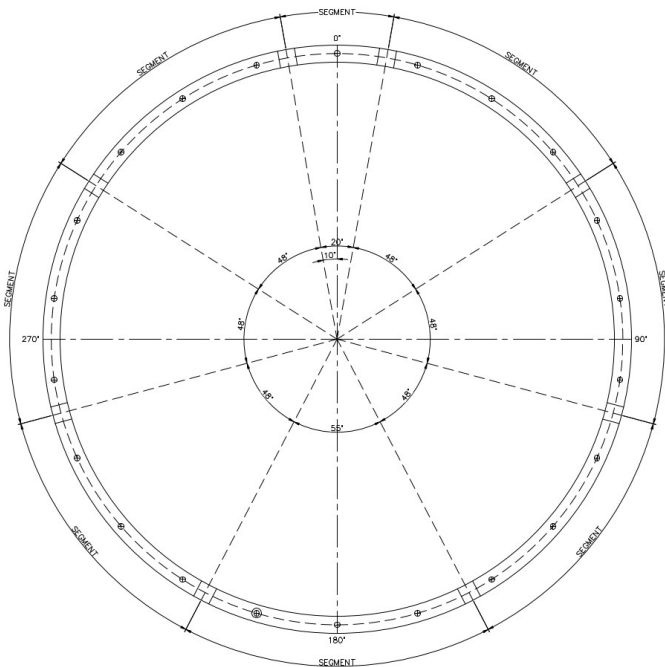
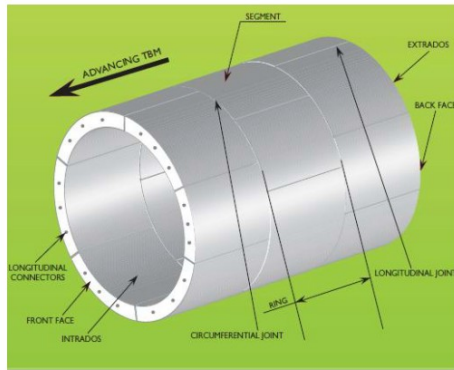

**Figure 13: Preferred Geometric Configuration of Segmental Lining Ring**

**Joints**

There are two types of joints in a segment radial/ longitudinal joints and circumferential joints. These joints are source of leakages in the tunnel and water tightness in these joints are ensured by providing gaskets. Figure below shows typical scheme of these joints in a precast segmental lining ring. All the segment radial joints are proposed to be tapered in the slope of 1 in 5.

**Radial/ longitudinal Joints**



**Figure 14: Features of Segmental Lining**

The radial joints are meant to transfer the ring interface forces resulting from external influences. In addition to these forces, the pre-tensioning forces required for the compression of the sealing are applied and absorbed here.

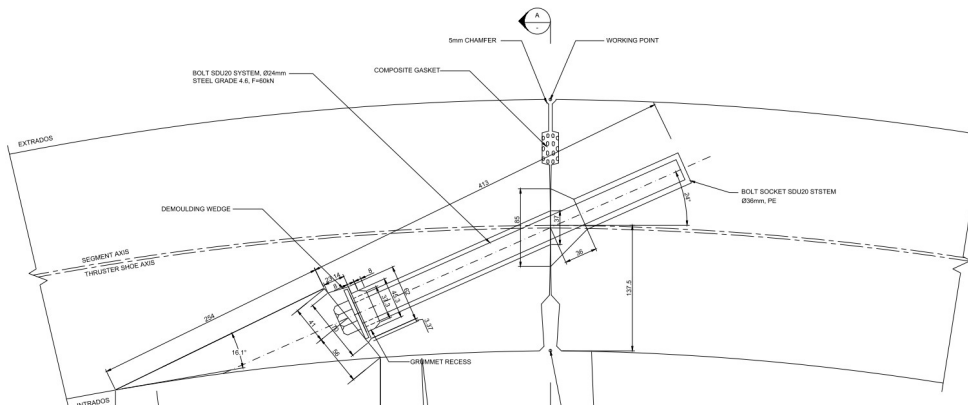

**Figure 15: Typical View of the Radial Joint in a Segmental Lining**



Technical requirement:

Length:	375 mm
Thread pitch:	M27 x 6 mm
Head size:	41 mm
Material grade:	8.8
Finish:	Hot dip galvanized



**Figure 18: Typical Cooper and Turner Bolting System for Precast Segmental Lining Joints**

**Dowels**

Dowels are preferred in the circumferential joints instead of the normal T or Banana bolts to connect one precast segmental lining ring to another. These dowels have high shear strength and by providing these dowels the pockets of bolts from the segments at the circumferential locations of the ring can be omitted.

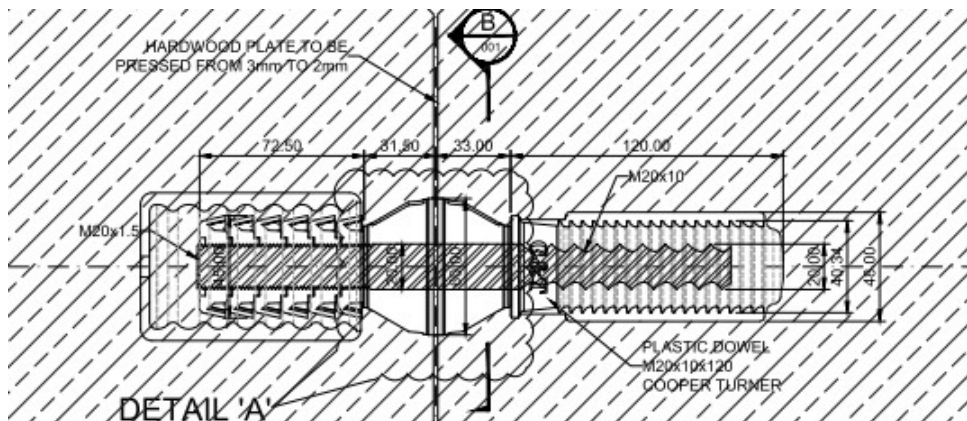

**Figure 16: Typical View of the Dowel for Circumferential Joints**

**Grout and Lifting Sockets**

Grouting and lifting sockets are provided in the intrados of the precast segments. These sockets are used to facilitate lifting, placing and grouting in the segments.

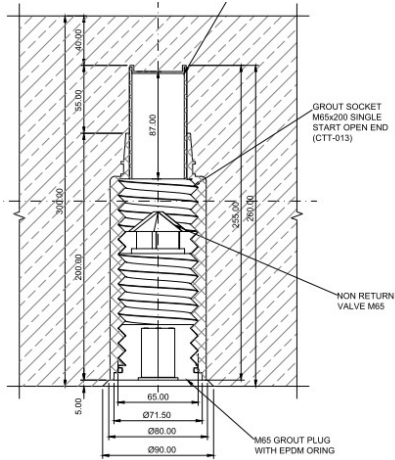

**Figure 20: Typical View of the Grouting and Lifting Socket for precast segmental lining**

### Annular Gap Grouting

The process of shield tunnelling with segmental lining leaves a gap between the excavated ground and the lining; this gap is termed as the annular gap. This gap has to be filled with a suitable material in order to provide the appropriate bedding for the segment tube and to ensure a uniformly distributed transfer of the loading from ground pressure.

The consumption of the typical cement bentonite grout is high in soft ground than rock strata due to high annular space. Pea gravel grout is usually a preferred option for filling this annular gap when tunnelling in rock with a shield TBM and can be adopted in this project.

### Fibre reinforced segmental lining.

Globally tunnels have been designed with steel fibre reinforced segmental linings. A sample calculation for the steel fibre reinforced segments done for this tunnel are attached as anx4. Recently guidelines for design of steel fibre reinforced concrete precast segments in tunnels is attached in annexures.

### Precast Segmental Lining Design

#### a. Materials

- **Cement**

1. Ordinary Portland cement (OPC) of 33 grade, 43 grade and 53 grade conforming to IS: 269, IS: 8112-1989 and IS: 12269-1987, respectively, shall be used.
2. Portland pozzolana cement (PPC) conforming to IS: 1489 may also be used.
3. The Employer's Representative may give notice for the usage of sulphate resistant Portland cement conforming to IS 12330 for structural elements exposed to soil.
4. In all the cases cement shall meet the 28-day strength requirement of IS 8112-1989 or IS 12269-1987.

- **Concrete**

- a. The Density of concrete adopted shall be as below:
  - [a] 24 KN/m<sup>3</sup> prestressed concrete (IS 875 part I table-1 item 21 value rationalised)
  - [b] 24 KN/m<sup>3</sup> for reinforced concrete with 2% or less reinforcement (IS 875 part I table -1 item 22 value rationalised)
  - [c] 25 KN/m<sup>3</sup> for reinforced concrete with above 2 % reinforcement (IS 875 part I table-1 Item 22 value rationalised)
  - [d] 23 KN/m<sup>3</sup> for plain concrete (IS 875 part I 1987 table-1 item 20)
- b. Short term modulus of elasticity 'Ec', & Modular ratio 'm' shall be as per clause no. 6.2.3.1 & B-1,3(d) of IS: 456 respectively.
- c. Minimum grade of concrete shall be M45.
- d. Thermal expansion of coefficient:  $1.17 \times 10^{-5}$  /oC (cl.2.6.2 IRS Bridge Rules)
- e. Poisson's Ratio: 0.15 for all concretes
- f. Minimum cement content and maximum water content ratio as per table 5 IS 456.
- g. Strengths of concrete is the specified characteristics compressive strength of 150 mm cube at 28 days.
- h. Minimum concrete cover as per IS: 456.

- **Reinforcement**

Only thermo-mechanically treated reinforcement bars conforming to IS: 1786 shall be adopted. (For seismic zone II, IV & V with minimum total elongation of 14.5 %)

- **Structural Steel**

- a. *General*

- (1) Design of Structural steelwork shall comply with IS 800.
- (2) Two types of structural steel to be used and shall comply with the following standards
- (3) IS 4923 "Hollow steel sections for structural use of Yst 310"
  - [a] IS: 2052 "Steel for General Structural Purposes (Grade B- Designation 410-B)"
- (4) Hollow steel sections shall be square (SHS) or rectangular (RHS). Other traditional rolled sections like plates, angles, channels, joists can also be used where required.
- (5) The connection with concrete shall be affected by internally threaded bolt sleeves (hot dipped galvanized @ 300 grams per square meters) manufactured from IS: 2062 Grade B mild steel. The sleeve shall receive hexagon-head bolt M20 Class 8.8 as per IS:1364 (Part 1) with galvanized spring washer.

- (6) The connections within the steel structure shall be designed as direct welded member with or without gusset plates. The minimum thickness of metal for SHS/RHS sections for main chord members as well bracings shall be 4 millimetres as applicable for steel tubes in cl. 6.2 of IS: 806.

## 2. Material Properties

Material properties shall be as follows:

Steel Type	Young's Modulus	Tensile Strength	Yield Strength	Density	Poisson's Ratio	Thermal Expansion Coefficient
For Hollow steel sections (Conforming to IS: 4923)		450 Mpa	310 Mpa			
Structural Steel (Conforming to IS: 2062)*	200000 Mpa	410 Mpa	250 Mpa (for t<20 mm) 240MPa (for 20mm <t<40 mm), 230 Mpa (for t>40 mm)	78.5 kN/m <sup>3</sup>	0.3	1.2 x 10 <sup>-5</sup> per °C

xxv. Note: Higher grade of steel can be considered as per IS2062 table-2.

Table 14: Steel Properties

### Design Criteria

#### A. Design Life

Civil engineering structures:

- xxvi. Main structure resisting ground and groundwater load: 100 years  
 xxvii. Non-structural components: 50 years

#### i. Ultimate Limit State

The segment design will consider the most critical load case with respect to water table, and the depth of tunnel. The maximum bending moment and its corresponding axial force are then used to determine the reinforcement required for the various load cases.

The segment is designed as a short column.

#### ii. Serviceability Limit State

Load Combinations and Load Factors Considered  
 Load Factor of 1.0.

#### iii. Material/ Factors

The following partial safety factors for material strengths are considered in the design as per IS456:

- xxviii. Concrete: 1.50  
 xxix. Reinforcement: 1.15

**iv. Concrete Cover**

xxx. Minimum Concrete cover of 50mm required as per IS 456.

**v. Crack width limit**

All structural concrete elements shall be designed to prevent excessive cracking due to flexure, early & long-term thermal shrinkage. Flexural crack width shall be checked in accordance with Appendix F of IS 456. The calculated maximum crack-width shall not exceed 0.2mm. The structural analysis will be carried out based on the worst-case loading under the service condition.

**vi. Allowable Deflection**

The maximum deflection under any load combination shall not exceed 25 mm on radius.

**B. Loads on tunnel**

The loads acting on the precast segmental lining due to the ground is estimated by Terzaghi approach. The precast segmental lining will be designed as watertight, considering this full water pressure is taken into account for calculating the forces on the lining.

**i. Empirical Approach**

**ii. Terzaghi's vertical loading theory**

Terzaghi's method is based on the assumption that ground relaxation is inevitable and requires steel supports. For obtaining the support pressure (p) from the rock load factor ( $H_p$ ), Terzaghi suggested the equation below:

$$P = H_p \gamma H$$

Where P is the support pressure

$H_p$  – Rock Load factor

$\gamma$  – Unit weight of rock

$H$  – Overburden

Table below shows the Terzaghi's rock load classifications for various rock classes. As per this table the rock load factor is assumed to be in between 0- 0.25 for massive moderately jointed rock conditions. For preliminary design purpose a rock load factor of 0.1 is proposed and used in design of the segmental lining.

**Table 15: Terzaghi's Rock Load Classification**

Rock class	Rock condition	Rock load factor $H_p$	Remarks
I	Hard and intact	Zero	Light lining required only if spalling or popping occurs
II	Hard, stratified and schistose	0-0.5	Light lining support mainly for protecting against spalling. Load may change

			erratically from point to point
III	Massive moderately jointed	0-0.25	No side pressure
IV	Moderately, blocky and seamy	(0.25 B- 0.35) (B+H <sub>t</sub> )	No side pressure
V	Very blocky and seamy	(0.35-1.10)(B+H <sub>t</sub> )	Little or No side pressure
VI	Completely crushed	1.10(B+H <sub>t</sub> )	Considerable side pressure. Softening effect of seepage towards bottom of tunnel require either continuous support for lower end of ribs or circular ribs
VII	Squeezing rock, moderate depth	(1.10-2.10)(B+H <sub>t</sub> )	Heavy side pressure, invert struts required, circular ribs are recommended
VIII	Squeezing rock great depth	(2.10-4.5)(B+H <sub>t</sub> )	Heavy side pressure, invert struts required, circular ribs are recommended
IX	Swelling rock	Up to 80 m irrespective of the value of (B+H <sub>t</sub> )	Circular ribs are required, in extreme cases use of yielding support recommended.

Notations **B** is the tunnel span, H<sub>t</sub>= Height of opening in meters, H<sub>p</sub>= height of loosed rock material above tunnel crown developing

### iii. Seismic Loads

Seismic design for tunnel structures involves the assessment of the tunnel structure to withstand earthquake induced ground borne seismic waves and associated differential ground movements. The tunnels will move as part of the ground during a seismic event and so their design for earthquake loading is primarily concerned with the accommodation of seismic waves and ground strain.

The seismic loads are treated as equivalent pseudo-static loads. As the project is located in Seismic Zone 3, the effective peak ground accelerations for horizontal direction is estimated to be 0.16g. It is suggested, the ground acceleration shall be reduced by the relationship between ground motion at depth and at the ground surface as per Table 4 given in the paper "Seismic Design and Analysis

of Underground Structure” by Youssef M. A. Hashash, Jeffrey J. Hook, Birger Schmidt and John I – Chiang Yao.

### C. Analytical Method to analyze the segmental lining for external loads

#### i. Muir and Curtis Approach

Muir-Wood (1975) presented a simple approach to the problem of proportioning the tunnel linings. He assumed that a circular lining deforms into an elliptical shape in an elastic ground. It is also assumed that a full interaction between lining and the surrounding ground exists. In the method proposed by Curtis (1976) the bending moments and axial forces developed in the lining of the tunnel are estimated similar to the Muir-Wood’s method except that the shear stress between the lining and the ground is taken into the account. The maximum bending moment and the maximum axial force developed in the lining is calculated as:

$$M_{max} = \frac{RR_e}{6}(2S_{nl} + S_{tl})$$

$$N_{max} = P_u R_e \frac{1}{1 + Q_1} - \frac{R_e}{3}(S_{nl} + S_{tl})$$

$$Q_1 = \frac{E_g(1 - \mu^2)R}{E_l(1 + \mu_g)A_l}$$

$$Q_2 = \frac{R^3 E_g(1 - \mu^2)}{12E_l l_l(1 + \mu_g)}$$

$$S_{nl} = P_d \frac{1 - Q_2}{1 + Q_2 \frac{3 - 2\mu_g}{3 - 4\mu_g}}$$

$$S_{tl} = \frac{1 + 2Q_2}{1 - Q_2} S_{nl}$$

Where,  $R_e$  is the external radius of the lining,  $R$  is the middle radius of the lining,  $P_u$  is the  $A_l$  is the area of cross-section of the lining,  $\mu$  is the Poisson’s ratio of the lining,  $\mu_g$  is the Poisson’s ratio of the ground,  $E_g$  is the elastic modulus of the ground,  $E_l$  is the elastic modulus of the lining. The detailed calculations for our case are presented below:

### TBM Tunnel Segmental Lining Design

#### INPUT DATA FOR LINING DESIGN

##### Concrete

Compressive strength	$f_{cu} =$	45	N/mm <sup>2</sup>
Tensile strength	$f_t =$	4.70	N/mm <sup>2</sup>
Density of concrete	$\rho_c =$	25	kN/m <sup>3</sup>
Material factor	$g_m =$	1.5	

##### Reinforcement

Yield strength	$f_y =$	500	N/mm <sup>2</sup>
Material factor	$g_m =$	1.15	

##### Tunnel & Segment Geometry

Internal diameter	ID =	13000	mm
Segment thickness	$t_s =$	400	mm
External diameter	OD =	13800	mm
Mean diameter	$D_m =$	13400	mm
Segment width	$w =$	1000	mm
Number of segments (excl. key)	$n =$	7	no
Segment angle (maximum)	$\alpha =$	55	°
Segment length (radial)	$l =$	6014	mm

##### Segmental Lining Properties

I value	$I =$	0.00533	m <sup>4</sup> /m
I value (adjusted for joints)	$I_j =$	0.00174	m <sup>4</sup> /m
Young's Modulus (short term)	$E =$	33,541,020	kN/m <sup>2</sup>
Poisson's Ratio	$\nu =$	0.2	

**TUNNEL LOADING AND FORCES**

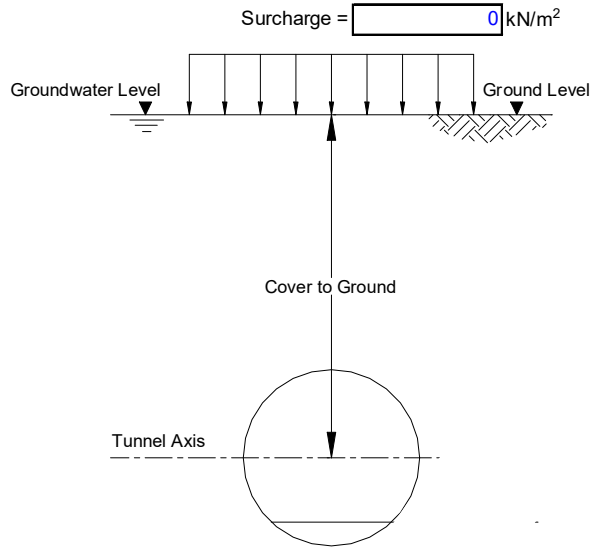

**Ground Properties**

Young's Modulus  
 Poisson's Ratio  
 Bulk Unit Weight  
 Drained Friction Angle  
 Drained Cohesion  
 Stress Ratio

Rock		Ground Type Input
$E_g =$	5000000	kN/m <sup>2</sup>
$n_g =$	0.25	
$g =$	27	kN/m <sup>3</sup>
$\phi' =$	65	°
$c' =$	400	kPa
$K_0 =$	0.33	

**Levels**

Ground level	333.000	m
Depth of cover (to tunnel axis)	339.700	m
Hydrostatic head to tunnel axis	40.000	m

**Ground Loading**

Surcharge	q =	<input type="text" value="0"/>	kN/m <sup>2</sup>
Overburden	=	<input type="text" value="9172"/>	kN/m <sup>2</sup>
Relaxation Factor for Rock	=	<input type="text" value="0.1"/>	Percentage Relaxation

**Combined loading on tunnel (at tunnel centreline)**

Vertical component (unfactored)	p =	<input type="text" value="917"/>	kN/m <sup>2</sup>
Horizontal component (unfactored)	q =	<input type="text" value="306"/>	kN/m <sup>2</sup>

**Curtis Equations**

*From Tunnels & Tunnelling, Nov 1974*

Assume I = unity. This implies that the lining is inserted immediately after the ground is excavated, allowing no relaxation of the ground and imposing full loading on the lining - a conservative assumption.

$$Q_1 = \frac{E_g(1 - n_1^2)R_m}{E_i(1 + n_g)h} \quad Q_3 = \frac{R^3 E_g(1 - n_1^2)}{12 E_i l(1 + n_g)}$$

$$S_n/S_0 = \frac{l(1 - Q_3)}{(1 + Q_3)w} \quad S_t/S_0 = \frac{l(1 + 2Q_3)}{(1 + Q_3)w}$$

where:

$$w = \frac{3 - 2n_g}{3 - 4n_g}$$

$$\backslash Q_1 = \text{input } 1.9177$$

$$\backslash Q_3 = \text{input } 1799.69$$

$$\backslash S_n/S_0 = \text{input } -0.80$$

$$\backslash S_t/S_0 = \text{input } 1.60$$

**Unfactored loads**

P <sub>0</sub> =	<input type="text" value="611"/>	kN/m <sup>2</sup>	\ S <sub>n</sub> =	<input type="text" value="-244.34"/>	kN/m <sup>2</sup>
S <sub>0</sub> =	<input type="text" value="306"/>	kN/m <sup>2</sup>	\ S <sub>t</sub> =	<input type="text" value="489.09"/>	kN/m <sup>2</sup>
N <sub>l</sub> =	<input type="text" value="1446"/>	kN/m	M =	<input type="text" value="3.05"/>	kNm/m
N =	<input type="text" value="-1688"/>	kN/m			

Water Pressure at the axis of tunnel	400 kN/m <sup>2</sup>
Thrust due to water pressure	2680 kN/m

**Summary**

**Unfactored**

Thrust at axis	T <sub>a</sub> =	<input type="text" value="5814"/>	kN/m
Thrust at crown	T <sub>c</sub> =	<input type="text" value="2438"/>	kN/m
Bending moment	M =	<input type="text" value="3.05"/>	kNm/m

**NOTE:** Forces here are per metre length and not per ring.

### 3. Seismic Design

Seismic formulas and calculations in this spreadsheet is based on " <b>Seismic design and analysis of underground structures</b> by Youssef M.A.Hashash , Jeffrey J. Hook, Birger Schmidt, John I-Chiang Yao"				
<b>5. Operating Design Earthquake</b>				
<b>INPUT PARAMETERS</b>				
<b>I Earthquake and Soil Parameters</b>				
Source to site distance	=		10.00	km
Mw	M <sub>w</sub> =		6.50	
Peak ground particle acceleration at surface	a <sub>max</sub> =		0.120	g
Apparent velocity of S-wave propagation	C <sub>m</sub> =		450.00	m/s
Soil unit weight	γ <sub>m</sub> =		27.80	KN/m <sup>3</sup>
Soil Poisson Ratio	ν <sub>m</sub> =		0.20	
<b>II Structural Parameters</b>				
Lining thickness	t =		0.40	m
Tunnel diameter	d =		13.80	m
Tunnel inner radius	r <sub>i</sub> =		6.50	m
Lining outer radius	r <sub>o</sub> =		6.90	m
Tunnel radius to centreline	r =		6.70	m
Width of Segment	b =		2.00	m
Depth below the ground	=		81.0	m
Concrete young's modulus	E <sub>i</sub> =		33,541,020	kN/m <sup>2</sup>
Poissons ratio for lining	ν <sub>i</sub> =		0.15	
Area of tunnel lining per unit width	A <sub>i</sub> =		0.40	m <sup>2</sup> /m
Max. Segment length (arc)	L =		1.94	
Lining cross sectional area	A <sub>c</sub> =		3.88	m <sup>2</sup>
Moment of inertial of the tunnel section (per unit width)	I <sub>c</sub> =		0.00533	m <sup>4</sup>
<b>Penzien's approach assuming Full Slip condition</b>				
1 Determine the racking ratio (Rn) and the displacement term Δ D <sup>n</sup> <sub>lining</sub>				
Estimate ground motion at depth of tunnel	a <sub>s</sub> = a <sub>max</sub> =		0.120	g
Assuming stiff soil	V <sub>s</sub> =	66	a <sub>s</sub> =	7.92 cm/s
				0.08 m/s
	$\gamma_{max} = \frac{V_s}{C_m}$			0.00
	$G_m = \rho_m C_m^2$			562950.00 kPa
	$E_m = 2G_m(1 + \nu_m)$			1351080.00 kPa

	$\alpha^n = \frac{12 E_t I (5 - 6 \nu_m)}{d^3 G_m (1 - \nu_t^2)}$	=	<input type="text" value="0.01"/>
	$R^n = \frac{4(1 - \nu_m)}{\alpha^n + 1}$	=	<input type="text" value="3.18"/>
	$\Delta d_{\text{lining}}^n = R^n \Delta d_{\text{free-field}} = R^n \frac{\gamma_{\text{max}} d}{2}$	=	<input type="text" value="0.00"/>
2 Determine the Maximum tangential thrust (T) and moment (M) due to S-waves:			
	$T\left(\frac{\pi}{4}\right) = \frac{12 E_t I \Delta d_{\text{lining}}^n}{d^3 (1 - \nu_t^2)} \cos^2\left(\theta + \frac{\pi}{4}\right)$	=	<input type="text" value="3.23"/>
	$M\left(\frac{\pi}{4}\right) = \frac{6 E_t I \Delta d_{\text{lining}}^n}{d^2 (1 - \nu_t^2)} \cos^2\left(\theta + \frac{\pi}{4}\right)$	=	<input type="text" value="22.26"/>
Note: maximum T and M occur at $\theta = \pi/4$ .			
<b>Penzien's approach assuming No Slip condition</b>			
	$\alpha = \frac{24 E_t I (3 - 4 \nu_m)}{d^3 G_m (1 - \nu_t^2)}$	=	<input type="text" value="0.01"/>
	$R = \pm \frac{4(1 - \nu_m)}{(\alpha + 1)}$	=	<input type="text" value="3.18"/>
	$\pm \Delta d_{\text{lining}} = \pm R \Delta d_{\text{free-field}}$	=	<input type="text" value="0.00"/>
1 Determine the Maximum tangential thrust (T) and moment (M) due to S-waves:			
	$T(\theta) = - \frac{24 E_t I \Delta d_{\text{lining}}}{d^3 (1 - \nu_t^2)} \cos^2\left(\theta + \frac{\pi}{4}\right)$	=	<input type="text" value="6.45"/>
	$M(\theta) = - \frac{6 E_t I \Delta d_{\text{lining}}}{d^2 (1 - \nu_t^2)} \cos^2\left(\theta + \frac{\pi}{4}\right)$	=	<input type="text" value="22.24"/>
Note: maximum T and M occur at $\theta = \pi/4$ .			
<b>Wang's approach assuming Full Slip condition</b>			
1 Determine the flexibility ratio (F) and full-slip lining response coefficient (k1)			
	$F = \frac{E_m (1 - \nu_t^2) r^3}{6 E_t I (1 + \nu_m)}$	=	<input type="text" value="308.40"/>
	$K_1 = \frac{12(1 - \nu_m)}{2F + 5 - 6 \nu_m}$	=	<input type="text" value="0.02"/>
2 Determine the maximum tangential thrust (T) and moment (M) due to S-waves:			
	$T_{\text{max}} = \frac{1}{6} K_1 \frac{E_m}{(1 + \nu_m)} r \gamma_{\text{max}}$	=	<input type="text" value="3.42"/>
	$M_{\text{max}} = \frac{1}{6} K_1 \frac{E_m}{(1 + \nu_m)} r^2 \gamma_{\text{max}}$	=	<input type="text" value="22.93"/>

Wang's approach assuming No Slip condition				
1 Determine the no-slip lining response coefficient (k <sub>2</sub> )				
			$F = \frac{E_m(1 - \nu_i^2)r^3}{6E_tI(1 + \nu_m)}$	= 308.40
			$C = \frac{E_m(1 - \nu_i^2)r}{E_tI(1 + \nu_m)(1 - 2\nu_m)}$	= 0.92
	x=		$F[(1 - 2\nu_m) - (1 - 2\nu_m)C] - \frac{1}{2}(1 - 2\nu_m)^2 + 2$	= 13.36
	y=		$F[(3 - 2\nu_m) + (1 - 2\nu_m)C] + C\left[\frac{5}{2} - 8\nu_m + 6\nu_m^2\right] + 6 - 8\nu_m$	= 637.81
		K <sub>2</sub>	= 1+(x/y)	= 1.02
2 Determine the maximum tangential thrust (T) and moment (M) due to S-waves:				
			$T_{\max} = \pm K_2 \tau_{\max} r = \pm K_2 \frac{E_m}{2(1 + \nu_m)} r \gamma_{\max}$	= 677.74
			$M_{\max} = \frac{1}{6} K_1 \frac{E_m}{(1 + \nu_m)} r^2 \gamma_{\max}$	= 22.93
<b>SUMMARY</b>				
<b>Summary</b>	<b>Wang (1993)</b>		<b>Penzien (2000)</b>	
	Full Slip	No Slip	Full Slip	No Slip
<b>T (kN)</b>	3.42	677.74	3.23	6.45
<b>M (kN-m)</b>	22.93	22.93	22.26	22.24

#### 4. Main reinforcement calculations

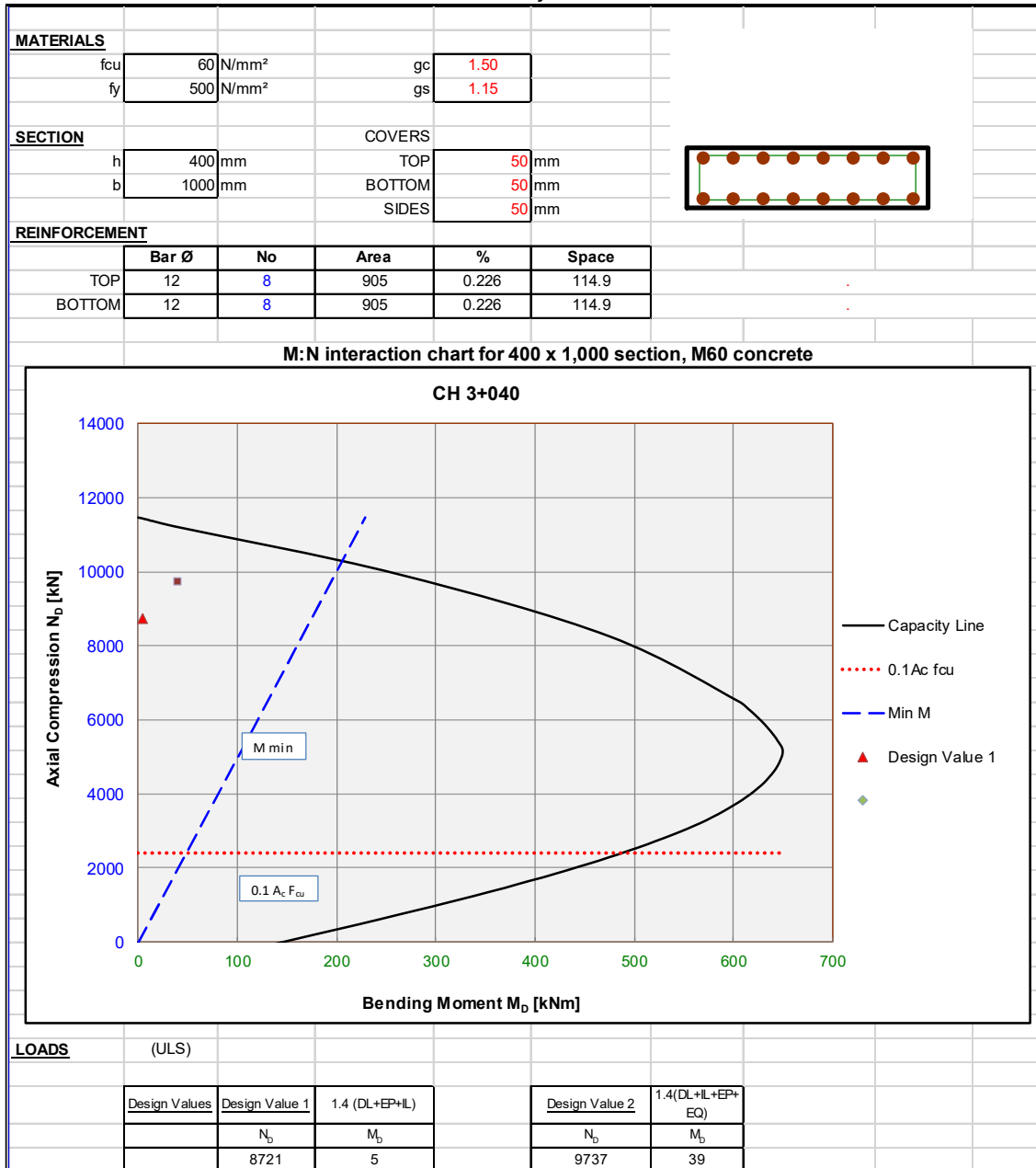

#### Segmental lining using Fibres

The tunnel segments can also be designed using polypropylene fibres. A sample calculation for the same has is attached in Annexure A.

## 6.11 E&M works for the tunnel

### Tunnel Cross Section with E&M equipment

The geometry of tunnel is very important aspect of tunnel design. The main objective of road tunnel is to ensure safe transit of traffic for which the facility is designed at least cost. The geometry of the tunnel is dependent upon projected traffic volume, provision of ventilation system, geology of the area and provision of pedestrian traffic. The finished width of a tunnel depends upon the number of traffic lanes required considering future projected traffic and the number and width of footpath/walkways, kerbs, crash barrier and drains required to be provided.

Keeping in view the traffic calculation, type and forecast it has been proposed to have twin tube two lane each highway tunnel. As per IRC: SP: 84-2014, typical cross section for Two lane tunnel excavation type construction is proposed as shown below:

In case of twin tube tunnels, each tunnel tube with unidirectional traffic, tunnel will be connected at fixed distances of about 300m through cross passages for pedestrians and for vehicles. The clear distance between the two tubes shall be kept depending upon the type of strata and structural stability. A road tunnel cross section must be able to accommodate the horizontal and vertical traffic clearances, as well as the other required elements.

The typical cross section elements include:

- Travel lanes
- Shoulders/ shyness
- Sidewalks/Curbs
- Tunnel drainage
- Tunnel ventilation
- Tunnel lighting
- Tunnel utilities and power
- Water supply pipes for firefighting
- Cabinets for hose reels and fire extinguishers
- Signals and signs above roadway lanes
- CCTV surveillance cameras
- Emergency telephones
- Fire and safety protection
- Communication antennae/equipment
- Monitoring equipment of noxious emissions and visibility

- Emergency egress illuminated signs at low level (so that they are visible in case of a fire or smoke condition)

### Tunnel Services

The following section establishes design criteria and intent of mechanical & electrical systems for Tunnel. The basic goal of the design criteria is to develop a safe, reliable, maintainable, energy efficient and economical Mechanical and Electrical system for tunnel.

The design of tunnel services shall meet the following objectives:

- Provide the appropriate level of tunnel equipment and operation to contribute towards a safe tunnel environment for road users, local inhabitants, operators and maintenance staff.
- Addresses Tunnel Dilapidation Risks.
- Reduces Operational Risks.
- Increases Structural and Network resilience.
- Provide continuous control of internal air quality to meet the specified requirement;
- Provide adequate visibility levels in all conditions at all times of the day and night;
- Provide appropriate collection, treatment and disposal of ground water and surface wash waters;
- Provide mechanical ventilation and smoke control systems capable of fully functional continuous operation for a range of fire events;
- Provide emergency egress from all areas of tunnels; Provide emergency response facilities in accordance with operational standards required by the authority;
- Minimize whole life costs;
- Incorporate mitigation measures from risk analysis as per EU directive
- The strategy for design of tunnel services shall be to adopt minimum acceptable provisions, with due regard to international best practices.

The design of tunnel services shall achieve safe tunnel environment for following stake holders:

- Road users;
- Local residents;
- Tunnel owner and operator;
- Maintenance staff;
- Police and civil defense

- Fire Authority;
- Emergency services;
- Government control authorities;
- Basis of tunnel services design

The E&M Systems includes the following areas:

- Tunnel Ventilation System
- Power Supply System
- Tunnel Lighting System
- Water Supply and Drainage system
- Fire Protection System
- Communications and Traffic Control
- Tunnel Operation and Plant Control/ SCADA
- Buildings and Plant room facilities

#### **Tunnel Operation and Control (SCADA)**

#### **Tunnel Control Centers**

Tunnel control centres are to be located close to tunnel portals on LHS Portal (Ekata Nagar, Borivali East side) and RHS Portal (Tikuji-ni-wadi, Thane side). Henceforth, they will be referred as Control Centre building east, CCB(E) and Control Centre Building west ,CCB(W) as shown below:



**Plan view of Ramp and Tunnel area with the control centre building**

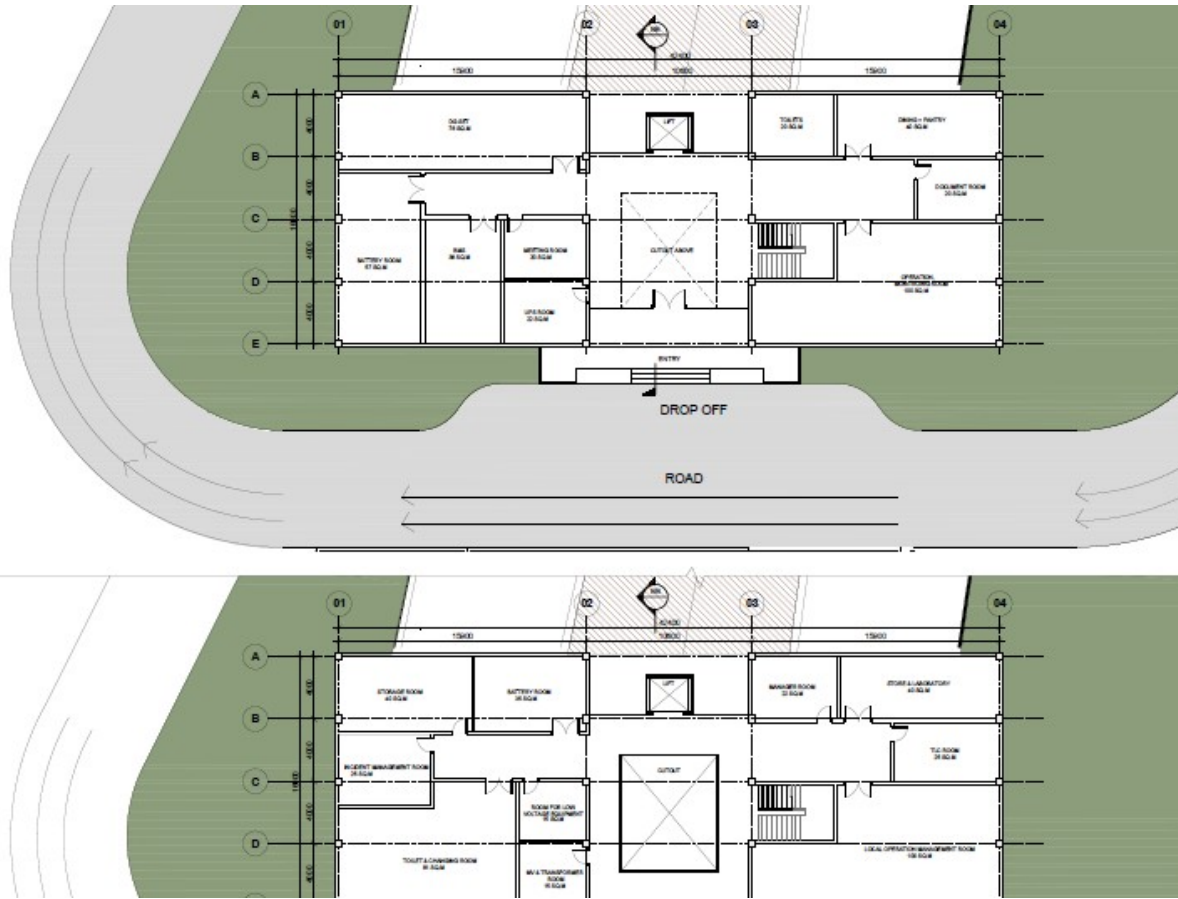

**Typical plan of Control Centre building**

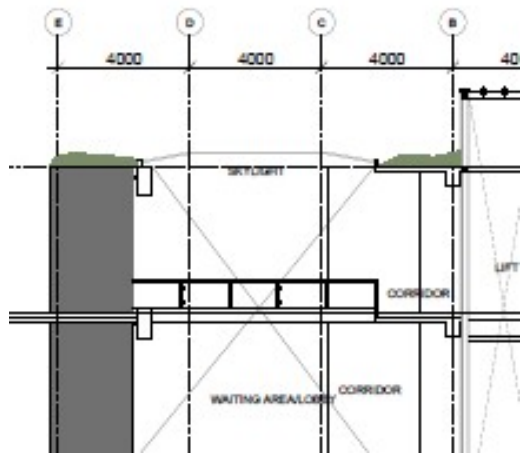

**Typical section of Control centre building**

One of them, the main local control centre shall be appointed for a non-stop attendance. The second one shall serve as a reserve one.

Tunnel operation shall be controlled from the above control centres located at the two portal buildings. The system shall automatically monitor and control all tunnel functions including Ventilation, Fire Detection and Protection, Traffic incident management systems and all Electrical and Mechanical plant. Control Centres is manned 24 hours a day and 7 days a week. Sub control centre will not be manned under normal conditions. However, full tunnel control shall be done from the sub control centre. A master switch and password protected access shall give the operator the rights for interventions to main or sub control centre.

The Tunnel Operating Authority (TOA) shall be the competent body, providing a nucleus of trained staff who will be fully familiar with the operation, inspection and maintenance requirements of the tunnel functions, together with the necessary maintenance plant and equipment, which is responsible for the tunnel operation and whose staff are also capable of providing advice and assistance to the police and emergency services.

There shall be clear procedures and clearly defined responsibilities agreed and laid down, with respect to traffic management and tunnel equipment, to ensure rapid and coordinated response to emergencies.

An emergency will normally be detected by Traffic Control Centre from the CCTV monitors, traffic loops, incident detector alarms or the emergency roadside telephones. Traffic Control Centre are then responsible for: the immediate summoning of the necessary emergency services; the immediate control of traffic entering the tunnel; alerting the TOA to provide necessary control of lighting, ventilation and pumping as required, and the setting up of diversions, traffic clearance measures and the issue of traffic information to minimise the effects of approach road congestion, in particular for dealing with the emergency.

The majority of incidents, such as vehicle breakdowns, shunt accidents etc. can be classed as “minor” and do not require more than the attendance of a “Traffic Officer” and a breakdown recovery vehicle. Traffic signing to close effected lanes and traffic control to deal with any build-up of traffic congestion downstream will be required.

A major incident may require a greater response, in terms of resources, than the normal response provided by the standard emergency procedures and will involve the possibility of severe personal injury or loss of life, the risk of a serious fire or serious damage to property and serious disruption to the traffic flow with consequent exceptional delay.

Tunnel operation procedures shall be developed by the Contractor in line with the risk analysis and shall be produced before the Employer and the fire authority for the approval.

### **Tunnel Control System**

Tunnel overall control is subdivided into three systems.

- Plant Management Control System (PMCS)

- Traffic Management Control System (TMCS)
- Operations Management Control System (OMCS)

PMCS ensures a risk-free environment for tunnel users, operators, local community and any amenities likely to be affected, by the operation of the tunnel. This system shall be responsible for the remote operation and monitoring of all subsystems including Ventilation, Traffic, Lighting, Fire detection, Power supplies, Security and Access control etc.

TMCS shall consist of traffic control and incident detection system through traffic lights, boom gates, variable message signs, variable speed limit signs, traffic counting using loop detectors, vehicle height detectors, CCTVs, PA and radio broadcast, and motorist emergency telephones.

OMCS integrates the plant management and traffic management system into one supervised and comprehensive operational system. The system shall be supported by local control systems, where if failure occurs in the central or associated control systems, local controls shall be able to go into a manual mode of control causing an alarm. OMCS shall also be the main processing and data storage centre for the tunnel operations.

The tunnel system communication network shall consist of a dual redundant data bus, i.e., the two fibre optic communication cables shall run individually along the length of the tunnel to connect each of the remote equipment. Communication requirements for motorist emergency telephone system shall be by separate dedicated fibre optic or copper cables. Fibre optic cables shall be installed in underground ducts of sufficient cover to ensure a fire rated enclosure (minimum of 2hr fire rating).

The TMCS shall:

- xxxi. Respond effectively to emergency situations in the tunnel in the shortest possible time frame
- xxxii. Optimise the traffic flows to prevent flow breakdown that leads to congestion
- xxxiii. Manage incidents effectively, through a comprehensive Incident Response System, to mitigate the impacts of Incidents and prevent occurrence of secondary incidents.
- xxxiv. Control voice communications to motorists in the tunnel over a radio broadcast system and public address system.
- xxxv. Monitor and control traffic control devices inside and outside the tunnel, including as a minimum:
  - xxxvi. Variable Speed Limit Signs (VSLS)
  - xxxvii. Variable Message Signs (VMS)
  - xxxviii. Automatic Video Incident Detection (VID) System
  - xxxix. CCTV system including surveillance cameras
    - xl. Boom Gates and traffic signals for closing tunnel entries
    - xli. Tunnel advisory signs
    - xlii. Traffic data Loops
  - i. Variable Speed Limit Signs (VSLS)

Variable speed limit signs shall be installed within the tunnel and on the tunnel portals. The entire tunnel shall be able to operate a variable speed control zone. The VSLs shall be double sided providing a speed display for vehicles travelling in both directions along the tunnel. VSLs shall be located at no more than 250m intervals and mounted on both sides of the tunnel above the pedestrian walkway.

ii. Variable Message Sign (VMS)

The VMS shall be a three-line type with a minimum of eighteen alphanumeric characters per line and shall be capable of displaying both Hindi and English messages. VMS shall be used to advise motorists of traffic conditions that include, but are not limited to, the following:

- Tunnel Closure Traffic Congestion Expected Delays Detour requirements
- Information to discourage vehicles entering the tunnel during major incidents

VMS shall be provided at traffic entry point to each tunnel portal.

The VMS shall be centrally mounted between 3m and 6m inside the entrance and angled to provide a viewing distance of 200m from outside the tunnel.

iii. Traffic Incident Detection System

The traffic incident detection system shall detect vehicle congestion and incidents and raise alarm to operators and generate data on traffic volumes and speeds. The detection of an incident occurring shall be by the following equipment:

- Automatic Video Incident Detection system
- CCTV Surveillance system
- Fire detection system
- Motorist emergency telephone

xliii.

iv. Automatic Video Incident Detection (VID) System

An automatic VID system shall be provided to alert operators to possible traffic incidents and unauthorized pedestrian movements throughout the full length of the tunnel.

The system shall have motion detection and vehicle/object presence software on the CCTV system capable of detecting in the tunnel the following:

- Slow moving vehicles
- Stationary vehicles, animals, pedestrians or debris down to 0.5m x 0.5m-visible area presented to the camera
- Wrong way / reversing traffic
- Smoke

v. Closed Circuit Television (CCTV) Surveillance System

The CCTV surveillance system shall be used to monitor the following:

- Traffic flow and incidents along the length of the tunnel
- Pedestrian movement
- Monitor security cameras in and around the tunnel portal buildings monitoring traffic approaching the tunnel portal
- Motorists Emergency Telephones

Emergency phones shall be independent from the normal telephones and shall have separate 2-hour fire rated cables, electronic circuits/control equipment and power supply including separate cable containment. These phones shall be located along with the Fire Cabinets at 100m spacing along the full tunnel length for motorists to report emergencies and traffic incidents. By lifting the handset, motorist can speak to the tunnel operator at the control room.

Emergency phone system shall provide calling number location reference data to the TMCS. The calling number reference location data shall be linked to the tunnel segment identifiers, CCTV camera number and pre-set view reference number. The TMCS shall automatically focus the nearest camera on the motorist using the telephone.

vi. Advisory signs

The advisory signs shall be capable of displaying a limited number of fixed messages and are principally located within the tunnel. The signs shall be supported on the tunnel side wall in the main tunnel at intervals of no greater than 60m as decided at detailed design on unobstructed support frames.

vii. Tunnel Access Control

The TMCS shall provide for the automatic closure and subsequent opening of the tunnel using sequenced and automatically controlled infrastructure and operation systems that:

- Stop all traffic in advance of the tunnel using boom gates and red traffic signals
- Alert approaching motorists of the stop with the VMS
- A tunnel close button shall be provided on the TMCS Operator workstation at each control room to initiate automatic close of the tunnel from both directions.

When the tunnel emergency close button is activated, the TMCS shall implement an incident response plan that causes an automatic and orderly closure of the tunnel up to the entrance portal, including activation of the traffic signals, displaying an appropriate message on the portal VMS and closure of the boom gates.

b) Traffic Lights

Traffic lights will be located at both tunnel portals and inside tunnel with spacing of 300m at height of 2.5m above emergency sidewalk. At least four 3 aspect (red, amber, green) 300mm diameter LED traffic signal heads shall be provided at each portal.

c) Boom Gates

The contractor shall supply and install four vertical lowering or horizontal swing boom gates with one pair at each end of the tunnel. Two gates shall be installed opposite each other each closing the two nearest lanes and meeting in the middle.

d) Hot Spot Detection System

Provide a detection system that will look for hot spots on each vehicle by pointing infrared cameras at them 1 kilo meter before the tunnel entrance. A camera or detection unit shall be provided at south portal control room end. If hot spot is found, the vehicle can be stopped at south portal entrance. Similar arrangements must be made for the northern end portal.

ix .Traffic Data Collection

Inductive loop detectors sites shall be used for traffic data collection. Loop detectors shall be installed inside the tunnel at or near the tunnel portal entry and exit for both directions. The following data shall be collected:

- Vehicle classification (number of axles)
- Vehicle speed
- Vehicle headway

xliv. Communication system

### SYSTEM ARCHITECTURE FOR INTEGRATE TUNNEL CONTROLS

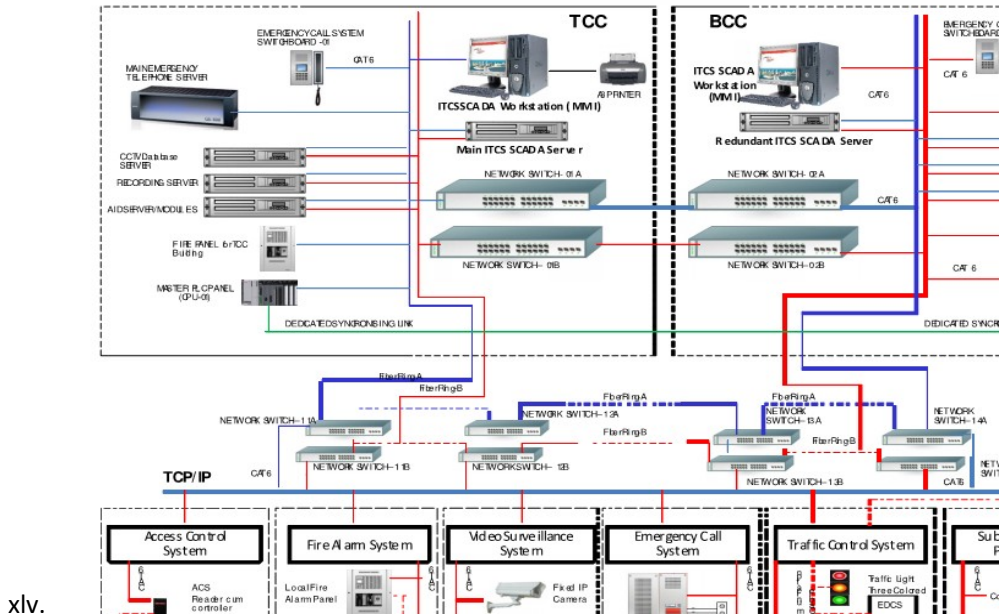

#### Public Address System

Public address (PA) system shall enable the operator to broadcast evacuation tones and give directions to motorists and maintenance staff in the event that the tunnel needs to be evacuated.

The primary objectives is to provide the tunnel operator with a means of communicating with the general public during an incident by agreed fixed call messages.

#### Radio Rebroadcast System

Radio rebroadcast facilities shall be provided to receive and re-transmit AM and FM radio station broadcasts and mobile phone operator services to motorists in the tunnels. Radio broadcast system shall consist of:

- Off air reception of AM/FM radio programs and VHF/UHF emergency services such as fire, ambulance, police and other similar services.
- In-tunnel rebroadcasting of VHF/UHF emergency services such as fire, ambulance, police and other similar services
- Mobile phone operator services

Break-in facility shall allow both automatic and manual insertion of audio messages by TMCS operators to provide instructions and advice to motorists in the tunnel by over-riding all the normal radio broadcasts on the vehicle AM/ FM radio receiver.

#### Emergency Call/SOS Box

The emergency call system consists of an emergency switch board on the workplace of operators and SOS boxes situated in front of the tunnel tube at both portals (one no. at each portal) and inside the tunnel tube installed at every 100 m spacing on both sides of main tunnel. The main purpose of the system is to assure verbal communication in between operator and a traffic participant for announcement and explanation/clarification of the appropriate emergency situation. The entry of any person to some SOS box shall activate telephonic communication with using emergency speaker phone and an amber warning flashing light above the SOS box, which is signalling some traffic problem.

The SOS boxes are sound-tight cabinets, made from stainless steel with degree of protection IP 65.

### Fire Safety Engineering

Fires in tunnels are particularly hazardous to life because of the potential concentration of fumes and poisonous gases, temperatures and heat radiation that can reach very high levels (1200°C and above), the possibility of panic among tunnel users and the difficulties which can be experienced by fire fighters working in an enclosed space. During evacuation, air temperatures of 80°C for 15 minutes, heat radiation of 2.5kW/m<sup>2</sup> (bare skin) and 5kW/m<sup>2</sup> (fireman in breathing apparatus for 30 minutes maximum) can be tolerated.

Visibility in smoke of 7m (necessary to make steady progress by walking) and 15m (to be able to read signs) is required. Normal walking speeds of 1.5m/s may be reduced to 1.0 - 0.5m/s within smoke. A fire incident in a tunnel can cause congestion or blockage of the carriageways, both inside the tunnel and on its approaches, such that fire appliance access could be delayed.

- **Fire in the Tunnel**

Fires in tunnel are a serious risk and the probability of such incidence is based on likelihood of a serious accident occurring inside the proposed tunnel and the vehicle involved catching fire. Tunnel alignment for tunnels have been maintained as straight alignment with maximum grade of 4% allowing high visibility distance.

- **Tunnel Firefighting water system:**

This consists of a fixed network of hydrants spaced at 100m through the Tunnels, in a ring configuration (wet pipe) closed at portals to the tunnels. A fire brigade booster connection will be placed outside every portal to enable Fire Brigade to pressurize pump water into the systems.

The control centre building (CCB) at the Eastern end will house two water tanks with sufficient capacity each and two groups of electrical pumps for pressurization of water in pipes and hydrants. A nearby firefighting station will have to house mobile firefighting equipment.

The hydrants will be placed inside cabinets equipped with 60m length of hose; close to every hydrant a sos box will contain a telephone, an alert button and two extinguishers The pumping system has to ensure that it delivers the minimum flow as per the detailed design by the contractor.

For tunnel fire, the first objective of using forced ventilation during a tunnel fire is to provide the conditions that allow the road user to escape safely from the site of the incident. This is achieved by driving the smoke away from the escape route direction, normally in the direction of traffic flow, in order to protect vehicle occupants who may be trapped behind the incident.

The second objective is to provide safe access to the fire by the emergency services, in order to control its spread and to extinguish it, thereby reducing the duration of the fire and its structural consequences.

Fire resistance of the tunnel structure is necessary to reduce the damage caused by the fire and minimise the time and cost of any reinstatement. Damage is dependent on both the fire load and the fire duration, the latter being determined by the capacity of the drainage and ventilation systems within the tunnel, the quantity of combustible material involved in the fire and the firefighting provisions available.

- **Management of Fire Risk**

Effective firefighting, in response to emergencies, depends on a comprehensive approach to the management of the potential risks involved and entails appropriate communications, traffic surveillance and control, adequate ventilation and drainage systems, tunnel layout for safety, emergency lighting and pre-planned and tested firefighting procedures.

An essential part of active fire protection of the road user is the provision of easily accessible emergency points at regular intervals throughout the tunnel. Emergency points shall be equipped with fire extinguishers, hose reels, fire mains and hydrants as required by governing local codes and fire authority. Escape facilities (e.g. cross connection passages), appropriate communication procedures and effective means of smoke control shall also be agreed at an early stage in the design process.

**Passive fire protection** shall safeguard the structural integrity of the tunnel e.g. providing adequate cover to structural reinforcement, spalling resistance etc including protecting firemen from spalling material and falling equipment; protecting power and communications cabling and ensuring appropriate provision is made for the fire resistance of mechanical components within the tunnel. Consideration shall be given to the effects of high temperatures on the integrity of fixings and supports, particularly for heavy or suspended items of equipment.

Passive protection for tunnel lining (NFPA 502) - Rijkswaterstaat (RWS) Time - temperature curve versus Megawatts

The advantages of passive fire protection systems are, amongst others:

- 5 Prevents rapid temperature rise in the structure

- 6 Prevents loss of strength and stiffness of the load bearing concrete lining
- 7 Prevents chemical degradation of the concrete
- 8 If designed properly, the concrete is not compromised
  - Concrete spalling can be prevented
  - Irreversible deflection can be prevented

As a part of passive protection for tunnel lining based on the PIARC (World Road Association) guidelines, the ITA (Structural Fire Protection for Road Tunnels) has provided recommendations to make tunnels and their ancillary structures more resistant to fire damage. Reason for developing guidelines - The behaviour of structures is a key factor to allow users to evacuate and rescue personnel to enter the scene and effectively perform their required duties and to limit damage to the tunnel. Improved specifications for tunnel fire resistance are required to mitigate the consequences of a serious fire, which could result in structural failure or complete collapse. The aim or focus of the protection may vary from preventing minor damage to preventing a total collapse both during the fire event and during the rescue operation.

with a thickness of 4 cm passive fire protection, the material can achieve the RWS fire scenario limits (380° C in the interface) for substantial more time than the required time of 3 hours

#### **Fire Detection and Suppression System**

The principal items of the Fire Detection and Suppression System for the Tunnel shall include:

- Linear heat detection System,
- Smoke Detection for buildings
- Fire Hydrant pump system,
- Fire Hydrants and Hose Reel System,
- Gas based Fire Suppression System,
- Hydrocarbon Gas detection system

#### **Fire Detection**

A fully addressable fire detection system complying with Indian standards shall be provided comprising Main Fire Control Panels in the control centres. Fire detection system will be integrated with Tunnel Control System and will be characterized by:

- Fibre optical linear heat detector cable for tunnel fire detection
- Heat and smoke detectors for service building fire detection
- Manual alarm button located inside Emergency/SOS boxes, in service buildings and at each cross passage.

Tunnel fire detection system shall include a linear heat detection system for the entire length of the tunnel and additional detector loop to serve ancillary equipment and areas such as the

PLC/RTUs, Electrical Distribution Boards. Linear detection fibre optic cable shall be installed along the tunnel centre line above the roadway. Linear Heat Detection (LHD) cable is essentially a two-core cable terminated by an end-of-line resistor (resistance varies with application). The two cores are separated by a polymer plastic, that is designed to melt at a specific temperature, and without which causes the two cores to short. This can be seen as a change in resistance in the wire.

Fire alarm control panel will allow the monitoring of the fibre optical linear heat detector cable; the fire alarm will be transmitted through the communications network to the main and redundant PLCs station.

SCADA system will proceed to accept the fire alarm signal and implement the required emergency procedures. Once the emergency is over, the fibre optical linear heat detector cable line shall be restored.

The technical rooms' Fire Alarm system shall comprise the following:

- Analogue Addressable Smoke Detectors, heat detectors, combined optical and heat detector
- Fire Alarm Control Panel
- Addressable Manual Call-Points

Fire Cabinet shall be integrated with Emergency/SOS Box, located at 100m intervals in the tunnel and shall include:

- Reed switch monitored Access Door,
- Emergency bush button/ Manual Call Point
- Two (2) x portable Fire Extinguishers,
- Motorist Emergency Telephone, and
- Signage
- Hydrant Outlet

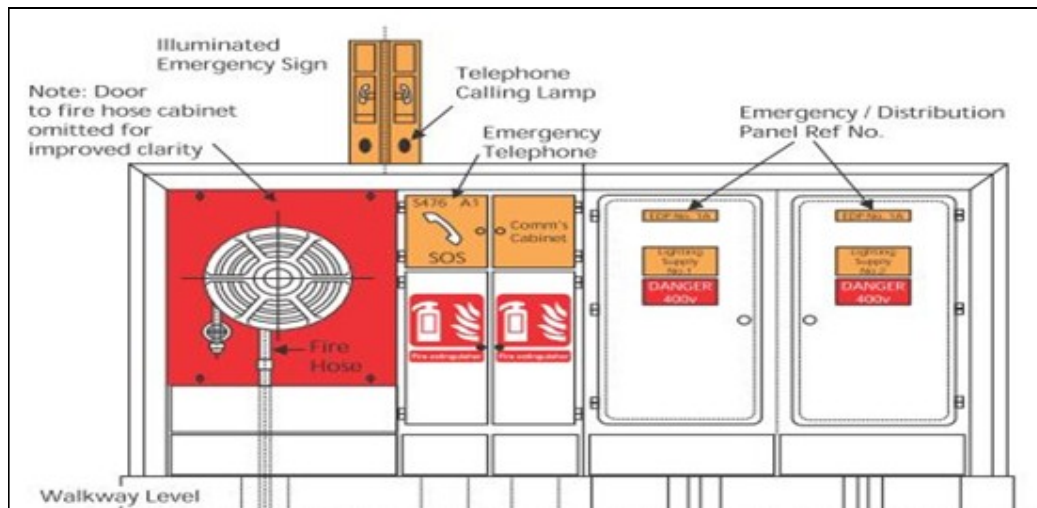

**Fire Suppression:**

Automatic Fire hydrant system shall be provided throughout the tunnel. Two ring main configurations shall be provided, one each for two Portal ends. Each Ring Main configuration will have its own electrically driven pump sets (1 Main + 1 Standby + 1 Automatic Jockey Pump set). The location of the fire tank and pump set shall be at the portals and these shall be sized at the design stage

The overall fire hydrant system mainly consists of:

- Twin water R.C.C. Storage Compartment at both the portal
- Pumping systems from a dedicated bore well or from a nearby water source.
- Automatic Sprinkler System
- Pipework and Hydrant Outlets.

xlvi.

#### **Hydrant Outlets:**

Hydrant outlet shall be installed in Emergency/SOS box, 100m apart. Each Hydrant point is equipped with two 63 mm landing valves.

It contains two standard hose connection outlets, 2 x 15 m fire hoses, a telephone, an alert button, a 9 kg CO2 Extinguisher and a 9 kg dry chemical Extinguisher. All are in a red painted fire cabinet.

Each of the Fire hydrant line will be connected with flow switches so that operation of fire hydrant could be monitored on the Fire Alarm Panel. The fire mains for the tunnels shall be sized according to pressure and flow requirements and would have isolating valve. This valve would be lockable. The hydrant landing valves shall be located in an Emergency Telephone and Hydrant Cabinet, which also contains Hose Reels with coupling and Nozzle as well as Portable Fire Extinguishers

#### **Clean Agent Based Fire Suppression System:**

The modular type clean agent modules with inbuilt detector shall be installed in UPS/Battery room, SCADA server room in Control Centre.

The system will consist of Gas cylinders, nozzles, signs, strobes, Gas control panel and piping/fittings/direction control valves approved for clean agent installation. A common bank of cylinder shall be designed to suppress fire in the largest area of the building. An exhaust fan controls shall be provided on Gas Control panel to exhaust the clean gas after the event of Gas discharge. 100 % of stand by cylinders shall be provided in a suitable storage space. The storage will be a common space for the tunnel project and shall be nominated by Authority during final design.

Cross zone configuration for the detection system shall be provided. Each room will have two fire detection zones and receipt of fire signal is essential before the discharge of Gas.

#### **Hydrocarbon Gas Detection and Foam Suppression System**

A single oil separator tank is provided at each end of the tunnel and one at the middle. This tank will store the effluents and drainage from the roadways in the tunnel and tunnel structures. A Hydrocarbon gas detector shall be provided in each tank. The gas detector will provide a high level and low-level gas alarm level. An Infrared gas detector unit of FM/UL approved make shall be provided to detect the hydrocarbon gas.

### Manual Fire Extinguishers

Fire extinguishers are provided for all low voltage rooms in Service Buildings, SOS boxes, Electrical Substation niches and Operations Control Centre.

- The fire extinguishers shall be made of galvanized steel and shall be resistant against frost.
- The extinguishers in the Service Buildings and Cross Passage Niches are placed at an own substructure, fixed at the walls.
- For Electrical Substation niches 10 kg ABC type fire extinguisher shall be provided.
- For low voltage rooms 5 kg CO<sub>2</sub> type fire extinguisher shall be provided.
- For DG area 5 kg foam type fire extinguishers shall be provided.

### Drainage

Where approach roads run downhill towards one or both portals it is normal to provide sumps to intercept storm water flowing down the approach roads and to prevent it from entering the tunnel. For such cases the catchment areas can be large and consequently portal sumps need to have a generous capacity.

In addition, where there is low point within the tunnel, an additional sump is provided to collect any water from the road surface inside the tunnel. Because most storm water will be collected at the portals, this sump is normally sized to receive water from predicted ground water seepage, tunnel washing and the use of fire hydrants, as well as possible spillages from vehicles.

The maximum quantity of precipitation to be expected within a given rainfall catchment area can be obtained from records and hydrographs published by the Meteorological Office, classified according to various “storm return periods”, usually 20-year, 50 year and 100-year storms. The maximum quantity of water to be stored is usually assessed, by integrating the area under the hydrograph, for a storm and runoff of 60 minutes. The amount of storm water that enters the tunnel and its approaches, and has to be removed, will depend on the position and level of the tunnel in relation to the local topography and the sizes of the catchment areas.

To cater for the wide range of possible inflow rates, sumps are provided with automatic controls which will regulate the number of discharge pumps operating according to the water level in the sump. The rate of pumping water out of a sump does not necessarily need to be the same as the rate of inflow provided that the sump has adequate storage capacity, and the sump design needs to be coordinated with that of the pumping equipment to achieve an optimum solution.

Because of the risk of spillages of petrol and oil, which in quantity could give rise to an explosive atmosphere in sump and a major safety risk, sumps are equipped with ventilation and sensors which will detect a build-up of common hydrocarbons and will initiate automatic protective measures to prevent an explosive atmosphere developing. These measures include flooding the sump with foam to prevent ignition and shutting down pumps and sump ventilation fans to confine the hazard until it can be dealt with and purging electrical machinery and switchgear rooms with eg carbon dioxide.

Sumps shall be provided with hydrocarbon gas and oxygen deficiency detectors to deal with the effects of a hazardous spillage. Closed sumps shall have fixed nitrogen foam systems, for fire protection or making inert. Additionally, a dry inlet shall be provided for the remote application of foam by the fire brigade. Foam concentrate shall be of the alcohol compatible Fluoroprotein or AFFF type and shall be used for extinguishing fires in sumps. Where foam is intended to be in place for protecting a sump for a prolonged period, facilities shall be provided for the injection of additional foam to top up the foam blanket by the Fire Brigade, as necessary.

## Tunnel Ventilation System

### Design Criteria & QRA (Quantified Risk Assessment)

The tunnel ventilation system shall be designed to:

- To ensure that the ventilation system and its associated equipment meet the requirements of BD78/99, PIARC, EU directive and NFPA.

#### A Quantified Risk Assessment

The NFPA 502 definition states that a Risk Assessment is a process or method that identifies the potential operational hazards together with their resulting probability and associated consequences to tunnel occupants and its structure.

NFPA Clause A.4.3.1

In simpler Terms performing a Risk Assessment requires identifying,

- Potential hazards (In this study only Fire is considered to determine Ventilation operational requirements).
- Determination of probability of such hazards occurring
- Resulting Consequences of the potential fire hazard

### Model Adopted

- The model adopted for the Thane-Borivali tunnel was the UK Highways Agency Road Tunnel Quantified Risk Assessment Model.
- This was Independently reviewed and approved for identifying Operational and Fire Risks on UK Road Tunnels.
- Satisfies Clause 50 of the European Directive on Operational Safety in Road Tunnels.
- Complies with the Road Tunnel Design standards NFPA 502 and British Road Tunnel Design Standard BD78/99 which are the two Design and Operational Standards respectively recommended for the SNGP tunnel
- Was used by Aecom to determine the Design fire Size for the Ventilation, Structural Fire Protection and the Design performance requirements for the Fire and Life Safety Systems on the Mumbai Coastal Road Project

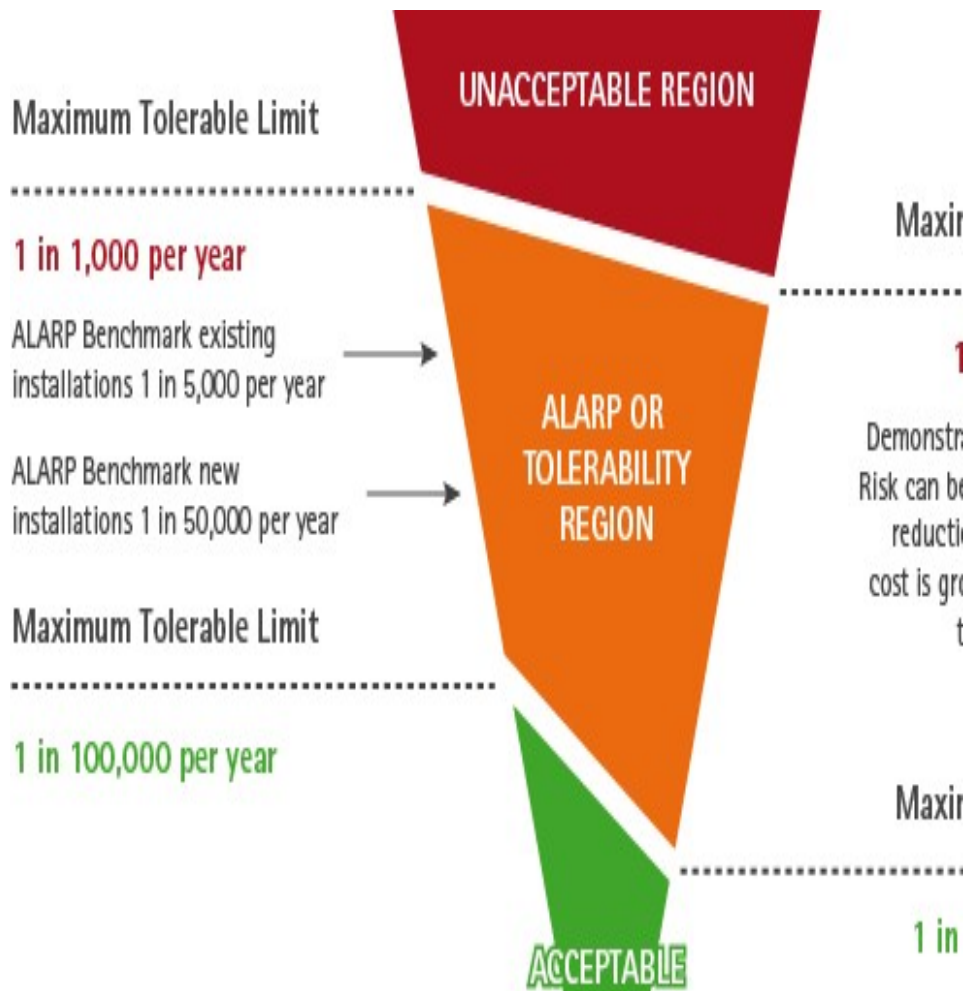

**Model Input Data:**

Data Input

Tunnel length – 10.2 Km

No of Bores – 2  
 Operational Days – 365  
 Growth Factor – 5.95% per annum Taken from an average of traffic data from 4 nodes.  
 Design Period – 20 years with commencement date of 2025.  
 AADT – 23750 vehicles per day for each bore  
 Traffic Mix  
 88% Cars, 2,3 & 4 wheeled vehicles  
 9% LCV & Bus  
 4% Trucks & Tankers  
 Cars etc. - 0.0208 / 100,000 Km Travelled.  
 LCV & Bus – 0.0236 / 100,000 Km Travelled.  
 Trucks – 0.0265 / 100,000Km Travelled.

### Model Output Data :

#### QUANTIFIED RISK ASSESSMENT OUTPUT

Project Name: SGNP Tunnel  
 Calcs by: Dr John Celestano  
 Date: 10th September 2022

#### Design Year 2025

Fire Classification	Fire Probability	Frequency (Years)
<10MW	3.176	0.31
10-50MW	0.096	10.37
>50MW	0.047	21.39

#### Design Year 2045

Fire Classification	Fire Probability	Frequency (Years)
<10MW	6.355	0.34
10-50MW	0.212	4.73
>50MW	0.1024	9.77

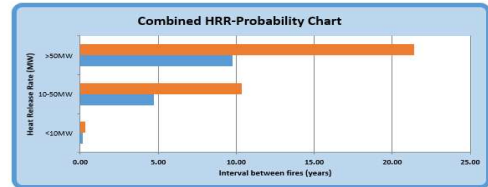
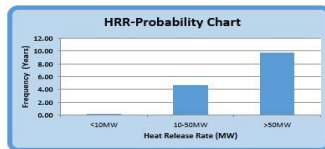
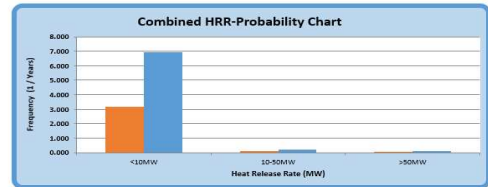
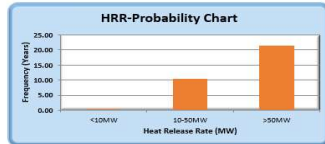

### The QRA Concluded the following,

- The probability of a small fire <10Mw will occur on average of 3 times per year increasing to 7 times per year after 20 years operation
- The probability of a medium size fire 10-50 Mw – 1 in 10 years increasing to 1 in 5 years after 20 years of operation
- The probability of a large fire 50-100 Mw – 1 in 21 years increasing to 1 in 10 years after 20 years of operation.

Increase in frequency primarily due to increase in traffic growth.

### Conclusions & Recommendations

The following can be concluded from the QRA,

- Since the probability of a large fire in excess of 100Mw will occur at least 5 times over the design life of the tunnel the Ventilation system should be designed to deal with smoke control from a 100MW fire.
- Design fire size for the project should be set at 100Mw
- All fire and Life Safety systems should be designed to cater for a fire of 100Mw.
- Since catastrophic structural damage will result from a 100Mw fire Structural Fire Protection should be included in the design of the structural. NFPA Mandatory requirement

- Design of the Ventilation, Tunnel Structure and Fire and Life Safety systems should comply with NFPA 502 & BD78/99. Philosophy adopted on Coastal Road Project
- Operational Philosophy and Procedures should be developed to cater for such large fire incidents.
- Based on above calculations and considering the site challenges and constraints, The Ventilation system be based on Saccardo injectors stationed at the beginning and end of both the tunnel portals. These Saccardo injectors should be of reversible system.
- If required, an additional booster system can be placed in the mid of tunnel by means of creating an Adit in the tunnel crown should it be required to increase the efficiency. The Option of using the booster set up can be seen based on the detailed design once the contractor is on board.

- **Fresh Air Requirements**

The ventilation system will maintain air quality in the tunnel in accordance with the recommendations of Highways Agency Standard BD78/99. Fresh air requirements will be calculated using PIARC emission rates in accordance with the recommendations of the latest relevant PIARC reports. Pollution Upper Tolerance Limit. CO: 100 ppm, NO<sub>2</sub>: 5 ppm, Visibility Factor: 0.007/m

- **Pollution and Vehicle Emissions**

The ventilation system shall also be designed to cater for existing traffic conditions and emission conditions and under all reasonably foreseeable traffic conditions and adverse weather conditions. The traffic study conducted in DPR to be referred for traffic data.

## Design Description

As per EU directive 2004/54/EC, In tunnels with congested unidirectional traffic, longitudinal ventilation shall be allowed only if a risk analysis shows it is acceptable and/or specific measures are taken, such as appropriate traffic management, shorter emergency exit distances, smoke exhausts at intervals. Transverse or semi-transverse ventilation systems shall be used in tunnels where longitudinal ventilation is not allowed as per outcome of above point.

As the tunnel is urban tunnel, appropriate traffic management can be envisaged. There shall be emergency cross passages to the adjacent tunnel at every 300 m. The Contractor should take note of the requirement of the pressurization of the non-incident tunnel and ventilation/pressurization of the cross-passages.

Jet Fans based longitudinal ventilation would result in large air velocities in the traffic space and thereby to a fast spread of smoke in case of a tunnel fire. In addition, powering the Jet Fans require multiple electrical and control panels within the tunnel space along the length, which may be quite a task for installation as well as maintenance. For this reason, the Saccardo Nozzle based system of longitudinal ventilation is considered.

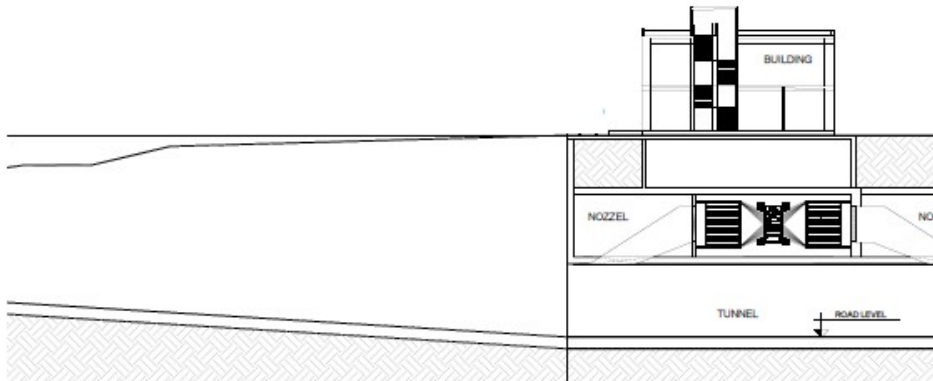

### GA of Saccardo Fan Station

In the proposed Saccardo Nozzle based ventilation concept, In both tubes, a technical room with the injectors is placed at the beginning of the tunnel, at a distance of 100 meters from the beginning of cut and cover section. There shall be 3 sets of plantrooms (Ventilation Station, VS) placed at four portals and one at mid-tunnel section. This system necessitates space availability at the portals for the plantrooms.

This system works on the principle of push-pull ventilation to create air flow in the tunnel in the desired direction. Therefore, there shall always be two sets of Ventilation Stations working together on both ends of the ventilation section.

The plant room shall consist of set of axial fans serving a common duct to deliver the air into the tunnel through a saccardo nozzle.

Due to geometrical constraints, no control, power or operational equipment will be installed within the tunnel bores and the existing fans, supports, cables and control equipment will be removed. However, environmental monitoring equipment will still be located in the tunnel bores.

The ventilation system should be designed such that the ventilation in each tunnel will continue to be achieved under single fan failure conditions.

The saccardo injectors should be of reversible and this way it is possible to avoid smoke circulation at portals and keep the non-tunnel free of smoke. In a fire scenario, the flow must be in the same direction in both tubes, so that the smoke existing from the fire tunnel cannot be sucked in to the non-incident tunnel.

The physical size of the ventilation plant will be kept as small as is reasonably possible, to limit visual intrusion of the ventilation buildings. Tunnel maintenance procedures will be designed such that all routine maintenance including fan replacement can be undertaken without road closures.

The bores are used predominantly as uni-directional. Contra-flow is used on an occasional basis for maintenance when they operate under traffic management. A quantified risk analysis shall be carried out to establish the requirement for a reversible ventilation system.

- **Fire Load**

It is proposed to reject all vehicles carrying flammable and dangerous goods in entire tunnel section. This is to eliminate risk of such vehicle entering in to tunnels and getting involved into an accident. Such type of vehicles may cause fires of up to 200MW having disastrous effect on tunnel structure. Based on present traffic volumes the HGV percentage is likely to be less than 5% of overall traffic volume. Hence a 100MW fire is adopted for design of ventilation to bring the impact to an acceptable level.

- **Air Velocity**

The maximum air velocity inside the tunnel due to the ventilation system shall not exceed 11 m/s to permit passengers to safely walk in the tunnel during an emergency event. It is recommended to limit airflow velocity in the air-ducts at to the order of 15 m/s to limit energy losses.

- **Fresh Air requirement**

For the normal operation the tunnel ventilation system has to provide the required amount of fresh air in order to obtain an appropriate tunnel air quality. To avoid an underestimation of the ventilation system in normal operation, the traffic data to be used for the fresh air calculation is Year 2050 for the number of vehicles and Year 2020 for the emissions standards of the vehicle.

- **Monitoring and control**

It is recommend having flow measuring devices at suitable intervals on suitable places free from interferences with installations devices for each ventilation section.

Under normal operational conditions the system will be controlled automatically via the Tunnel Pollutant Monitoring and Control System in response to pollution levels within the tunnel including presence of explosive/flammable gases and fumes.

### **Normal Operation**

Under normal operation or congested traffic conditions the SCADA will only start sufficient fans to ensure that environmental conditions do not exceed the required values. The direction of airflow will always be in the direction of traffic flow.

The ventilation system will be operated in accordance with set operational and emergency procedures in response to the following:

- Rising levels of Carbon Monoxide
- Rising levels of Oxides of Nitrogen (NOx)

- Poor visibility / obscuration
- Detection of smoke
- Detection of explosive/flammable gases and fumes

### **Operation under Fire Conditions**

In the event of a fire in the tunnel, the installed video automatic incident detection (VAID) and linear cable heat detection system will detect the presence and location of smoke and will raise an alarm on the SCADA GUI.

The Operator in control of the tunnel systems at the Control Centre will confirm if there is a fire in the tunnel and initiate operation of the ventilation system in accordance with set emergency procedures by means of the SCADA. The flow of air in the incident bore will always be in the direction of traffic flow, thus ensuring that smoke will always be directed away from people trapped behind the fire location. The requirement of contra flow to the traffic direction needs to be checked in risk analysis.

Pre-determined operational and emergency procedures will be available in the operator interface. These procedures will take into account the location of the fire, the possible presence of tunnel users downstream of the fire, cross-passage ventilation and non-incident tunnel pressurization. These operational and emergency procedures will be integrated into the control software and available for display on the Operator's screen on request.

### **Sensors and measuring instruments**

#### **In-Tunnel Environment Monitoring**

The tunnel environment will be monitored by the following:

- a) CO sensors
- b) Visibility (haze) sensors
- c) Velocity meters
- d) NO sensors
- e) NO<sub>2</sub> sensors
- f) Explosive/flammable gases sensor

Provision shall be made in the system for the NO<sub>2</sub> measurement to the environmental control system by the use of computer calculation.

In-tunnel air quality monitoring equipment shall be located along the tunnel as indicated in the drawings.

Additionally, air quality monitoring equipment shall be located in the discharge ductwork of the

north and south portal tunnel ventilation system.

The Central Monitoring and Control System (CMCS) shall scan these sensors in configurable regular intervals. Any sensors failure detected will be reported at the Central Control Room (CCR) where such failure will be logged, and an alarm will be raised at CCR. The scanning interval will be set in order to meet the response requirement of this Specification.

Facilities to filter transient signals shall be provided to avoid spurious signals.

The measured levels of CO<sub>2</sub>, NO/NO<sub>x</sub> tunnel air velocity and visibility shall be recorded by the Central Monitoring and Control System (CMCS).

The CO and NO/NO<sub>x</sub> sensors shall generally be in accordance with AS1668.2 (or BS 5925/ ISO 16000-8/ BIS IS 9679) as applicable.

#### **External Environmental Monitoring**

The External Environment shall be monitored at both the North and South portal by the following:

- a) CO analyser
- b) Wind Speed and Direction sensors
- c) NO analyser
- d) NO<sub>x</sub> analyser
- e) Particulates (PM10)
- f) Dry Bulb Temperature.
- g) Barometric pressure.
- h) Relative Humidity.

The CO, NO and NO<sub>x</sub> analyser shall be connected digitally to the data acquisition system providing the advantages in remote communication and minimising analog to digital noise. The Central Monitoring and Control System (CMCS) shall scan these sensors in configurable regular intervals. Any sensors failure detected will be reported at the Central Control Room (CCR) where such failure will be logged, and an alarm will be raised at CCR.

## Tunnel Cross-passages

Cross passages within the tunnel section of the tunnel shall be provided at approximately 300m intervals. These cross passages will allow for the safe evacuation of people from one bore to the other in case of emergency (incident/fire emergency).

Each cross-passage shall be identified by a clearly visible number to assist with location in respect to an incident. The tunnel operating procedures shall clearly define the need to minimise the risk of people using cross-passages and emerging into the path of moving vehicles in the unaffected bore. Where there is room not to impede the vehicles of the emergency services during an incident, consideration may be given to the provision of demountable pedestrian barriers, opposite the doors only, to prevent users of the cross-passage doors moving into the live carriageway of the adjacent bore.



The opening of a cross passage door leading to a live carriageway shall activate suitable signals to warn drivers approaching the tunnel of the possible presence of pedestrians in the tunnel roadway.

The cross passages will have a ventilation system that creates, in the case of a fire event, an over pressure (30-50Pa with the closed door) that doesn't allow the smoke to pass from One tunnel to adjacent tunnel.

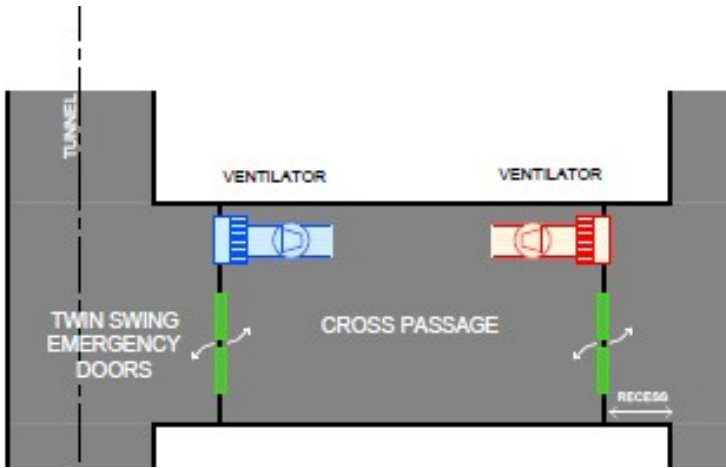

Use of Vehicle cross passage during Fire accident :In the event of fire,the Ventilation system located on the fire tunnel side be turned off as shown below:

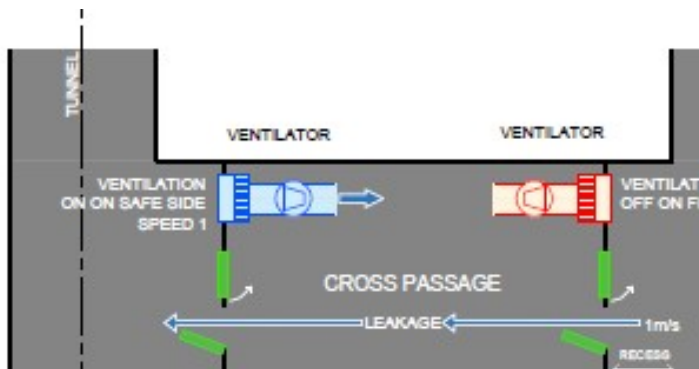
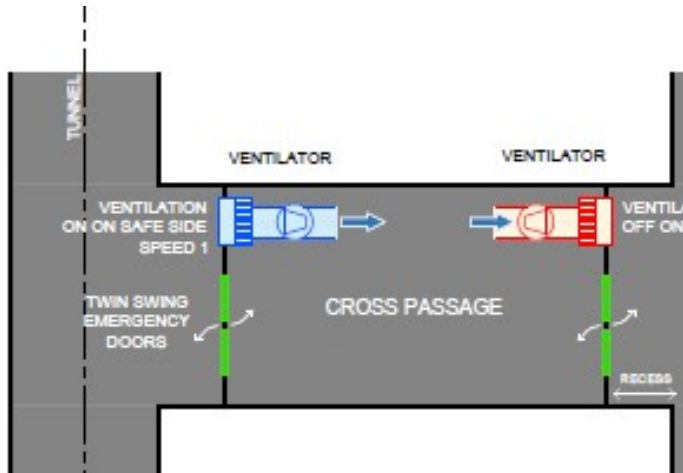

## 6.12 Tunnel Lighting System

As tunnel is a linear enclosed space, thus in broad daylight inside any tunnel is always dark.

During daytime when a vehicle approaches and enters a tunnel, a motorist has to travel from a brightly lit area into a lightly lit area. Thereafter when the motorist leaves the tunnel, he has to travel from a lightly lit area to a brightly lit area.

At night the situation gets totally reversed. When a motorist approaches and enters a tunnel, he has to travel from a dark area to a brighter lit area. Thereafter when the motorist leaves the tunnel, he has to travel from a brighter lit area to a dark area.

Thus, when a motorist travels through a tunnel, his vision has to get adapted to changing lighting conditions. This adaptation cannot be instantaneous but takes some short time. Such adaptation has to be a smooth transition and such smooth transition can be produced only by suitably designed lighting conditions at the entry and exit areas of the tunnel and the portion of the tunnel in between these areas.

Properly designed tunnel lighting ensures smooth transition of lighting environment between approaches to the tunnel and the tunnel itself. To enable the vision of a motorist to get smoothly adjusted to changing lighting environment, the approaches to a tunnel and the tunnel itself are divided into various zones as given below. Time for such smooth adjustment is generally considered as about 4 seconds. At a speed of 60 kmph, the length travelled in 4 seconds would be nearly 70 m.

- **Access Zone**

It is the portion of the open/approach cut of the tunnel immediately adjacent to Tunnel Portal. The Illumination Level in this zone is generally kept at around 70 candelas/sqm of road surface.

- **Threshold Zone**

It is the first zone next to the entrance to a tunnel. In the Threshold Zone, the intensity of lighting is gradually adjusted from that outside the entrance to that in the beginning of the transition zone. The Illumination Level in this zone is generally kept at around 40 candelas/ sqm of road surface.

- **Transition Zone**

It is the zone next to the Threshold Zone. In the Transition Zone, the intensity of lighting is gradually adjusted to that in the Interior Zone.

- **Interior Zone**

It is the zone beyond the Transition Zone. It is sometimes also termed as Normal Lighting Day Zone. In the Interior Zone, the vision of a motorist needs no further adaptation. This is the longest zone in case of such long tunnel. The Illumination Level in this zone is generally kept at around 15 to 20 candelas/ sqm. of road surface.

It would be good practice in the case of very long tunnels to provide some variations in lighting at regular intervals, through variation in intensity or colour of lighting etc., so as to break the monotony of traveling under the same conditions for a long distance. Extra lighting is required in lay-bys, emergency parking locations and at locations of escape paths and emergency services access locations.

- **Exit Zone**

It is the zone beyond the Interior Zone and between/before the exit portal of the tunnel. In the Exit zone, the intensity of lighting is gradually adjusted to that in the portion just beyond the Exit Portal.

- **Lighting Type & Installation**

The purpose of properly designed tunnel lighting is to ensure smooth transition of lighting environment so as to enable smooth adjustment in the vision of a motorist. Since requirement of intensity in the Threshold, Transit and Exit Zones during daytime is different than that during nighttime, required intensity can be achieved by putting the luminaries in two different circuits. Alternatively, luminaries that can give variable output by use of dimmers can also be used. Gradual increase or decrease in the intensity of lighting within different zones, as described above, can be achieved by installing different types of luminaries or by using one or two types of luminaries at a closer or wider spacing as required. For easier adjustment in spacing, the luminaries can be mounted on sets of ladders arranged in longitudinal direction and hung from the crown of the tunnel. Tunnel lighting has to be highly reliable. Tunnel lighting is required round the clock. Therefore, this is mandatory to have cent percent back-up system for Tunnel Lighting system.

All these luminaries should have high ingress protection ratings. Same should be sealed so as to prevent entry of water from water sprays, dust and smoke. The luminaries have to be cleaned frequently to clear dust and soot that may collect on their outer surface. Proper routine maintenance programme should be conceived and implemented.



Instead of waiting for the luminaries to fail before replacement, systematic replacement and renewal programme should be conceived and implemented. LED luminary of different wattage are proposed for the tunnel lighting.



Inside the tunnel LEP light fixtures shall be mounted on the wall/ceiling of the tunnel and outside of the tunnel LED Street light fixtures and high mast shall be provided.

### 6.13 Electrical System

#### Design Standards & Codes

- Electrical system design shall be in confirmation to the requirement of:
- Indian Electricity Rule 1956.
- Standards & Code Practice of Bureau of Indian Standard for various equipment & Systems.
- National Building Code of India -2016
- National Electricity Code of India

#### Design Criteria

##### Energy Efficiency:

- Use of energy efficient light fittings, ballast and LED light fixtures shall be considered.
- Provisions of SCADA to allow energy saving in off-peak operation.

##### Safety of the Passengers and end users:

- Strict compliance with Indian Electricity Rules & other safety code requirements.
- All Lighting and Power circuits shall be protected by the circuit breakers and RCCBs.
- Surge Arrestor shall be provided at the Main Panel and other SDBs/FDBs which has external in/out cable connections.
- Proper Signage shall be provided inside the Tunnel for Passengers
- Portal building shall be protected by the Lightning Protection System.

##### Reliability of the Installation:

- Transformers from two different sources shall be considered for redundancy.
- For Emergency Power DG sets are considered.

##### Flexibility and Adaptability

- Planning shall be in such a way that distribution system will not have major change in case of change in design of utilities.

#### **Maintainability**

- Space planning shall be done with consideration of regular service, maintenance; and future replacement.

#### **Expandability**

- Sufficient spare capacity (about 20-25%) in the design of switchboard and distribution network to meet future load growth.

#### **Electrical Load Estimation**

Sn. No	Description	Estimated Connected Load (kW)	Overall Max. Demand (MW)
1	Tunnel Ventilation	4500	5.57 (MW) 0.9 PF say $\approx$ 6.38 MVA
2	Portal Building	50	
3	Tunnel Lighting	500	
4	HighMast Lighting	25	
6	Portal Fire Room	500	

#### **Source of Power**

Total electrical power requirement for the project (overall maximum demand) shall be 5575 kW. It is proposed to source the power from 2 different power sources to have redundancy in the system to have emergency source of power also. The required power may be made available through DG Sets.

## Power Distribution System

Bulk 33kV HT supply up to Portal Substation shall be available from the nearest Supply Authority Switchyard. At the Portal Substations two numbers Oil/Dry type power transformers, 33 kV supply shall be stepped down to 11 kV voltage level. Portal Substations and cross passage niche substations shall be interconnected through 11kV ring lines. As the entire system falls in ring system, in case of failure of one supply, another can take care of total load of the tunnel system. One niche substation shall cater a length of 2 to 2.5 KM length for E&M equipment.

Each portal and niche substation shall have two numbers Dry type distribution transformers for further stepping down voltage to 415 V. This covers the complete 415V (3 phase 50 Hz) / 240 V (1 Phase 50 Hz) power supply, including main distribution panels, cabling and all required equipment, material, accessories as well as all work needed for the complete 415 / 240 V power supply.

Further distribution from will be through DBs located near the equipment / individual area load centres. These DBs will be fed from the specific utility panels inside the Portal.

For Electricity Measurement, Energy Meters shall be provided in the incoming and outgoing feeders of MV Switchgear panels. However, Electrical panels for each utility shall be provided with sub energy meters

33kV HT panel shall be Indoor metal-clad switchgear equipped with SF6 gas-insulated vacuum circuit breaker switchgear and associated equipment. The busbars shall be enclosed in SF6 Gas switchgear units. Bus Rating shall be 33 kV GIS, 25 kA 3s, Single Bus Bar of required rating.

## Portal Service Buildings

Tunnel Electrical Service Buildings are to be located close to tunnel portals on LHS Portal (Borivali East side) and RHS Portal (Thane side). The following equipment and installation have to be at service buildings.

- Facilities for the electrical power supply (Switchyard)
- HV switch room
- LV switch room
- Distribution Transformers
- Diesel Generator with fuel tanks
- UPS room with battery
- Plant Rooms for Tunnel Maintenance
- Fire water tank & pumping station shall be provided at both portals
- Storeroom
- Staff Room with Toilets

### Portal Substation Schematic (HV Distribution)

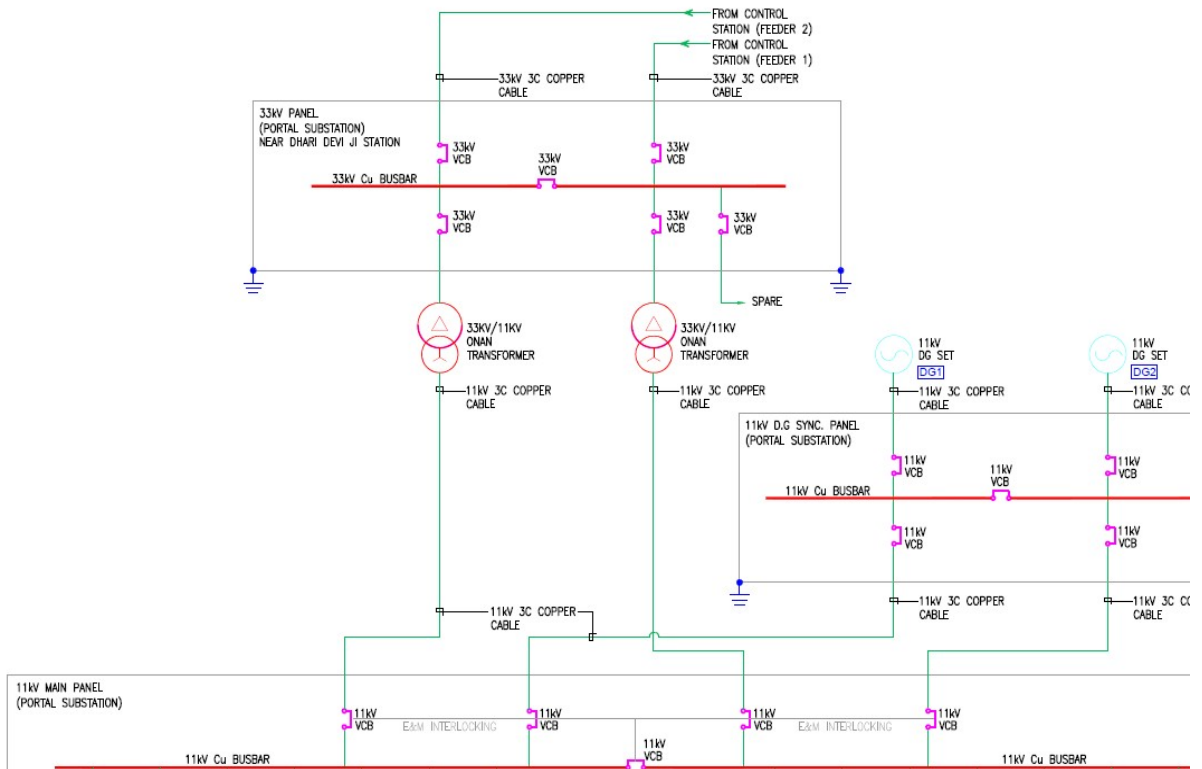

### Portal Substation Schematic

#### (LV Distribution)

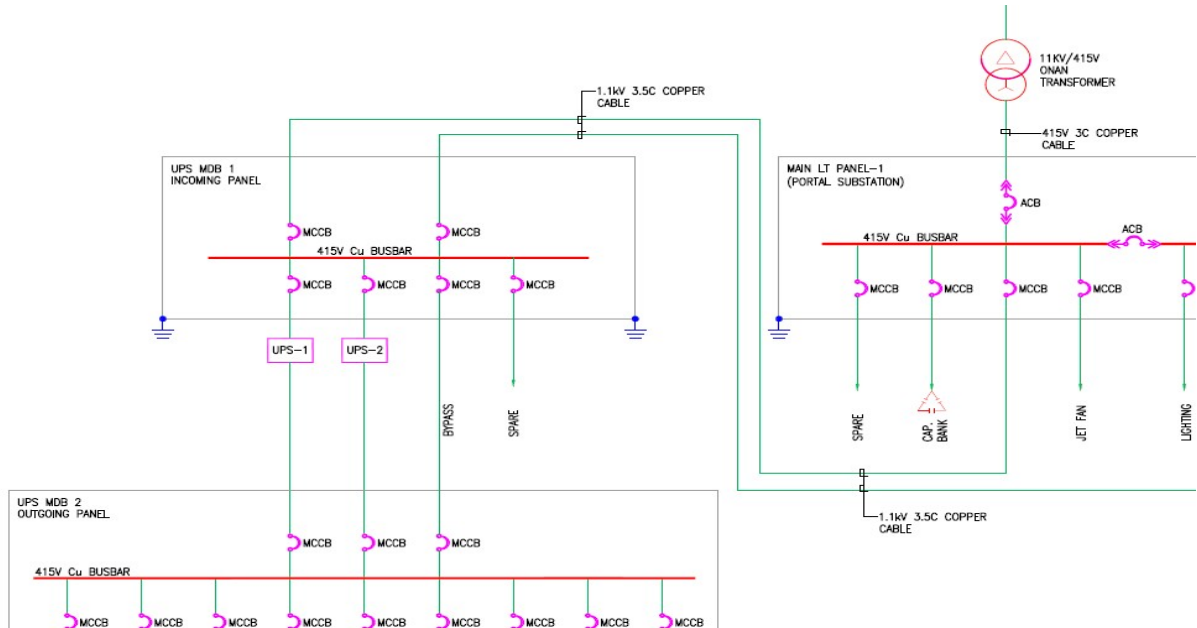

## Niche Substation Schematic

### (LV Distribution)

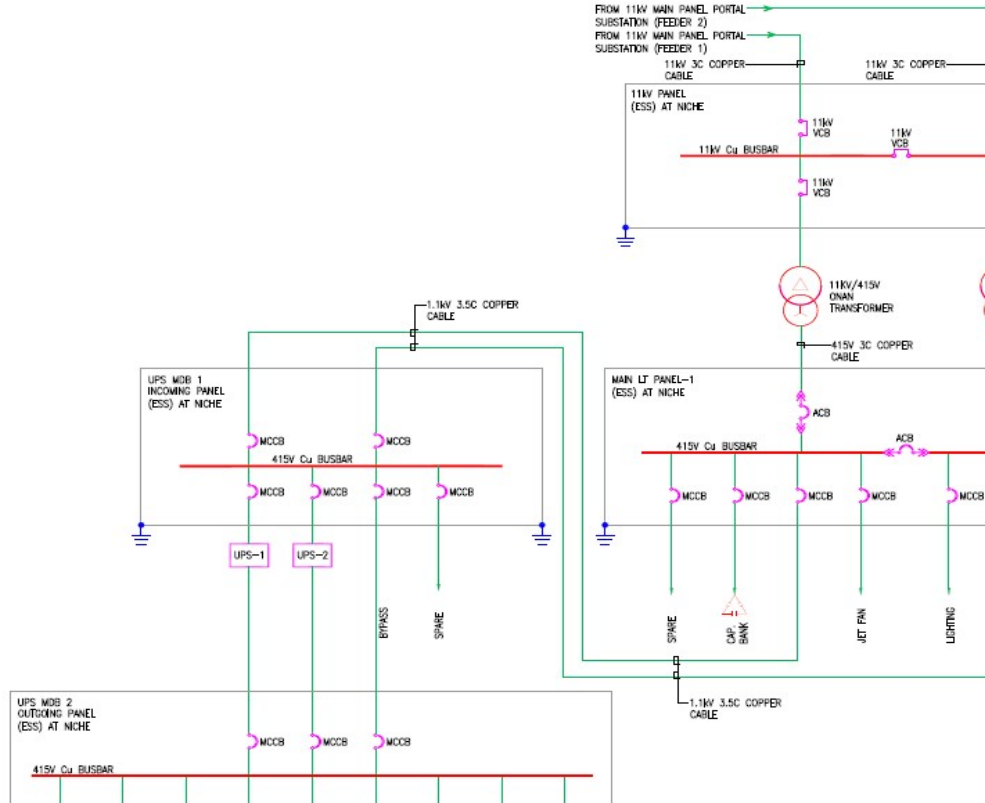

### **Transformer**

In 2 Nos. 33/11 kV Oil/Dry Type Power Transformers of adequate capacity shall be proposed at Electrical substation at portals. Two 11/0.415 kV Distribution Dry type Transformers of adequate capacities shall be placed at each of the portal-1 and portal-2 separately. Each niche substation (total four number niche substations are proposed) shall have two small distribution transformers to cater the load up to certain distance at the both side of a particular niche substation.

As a general rule, two transformers will be sharing 50% load each during normal condition. In case of failure of one transformer, the other transformer will take care of total loads, connected at corresponding substations.

### **Backup Power Supply**

100% Power backup is planned for the in the case of power outage and transformer maintenance. Two number of HT DG sets with acoustic enclosure are proposed to be placed only at Portal Substation for each Tunnel, These DG will deliver power to 11 kV Main Panel where all local 11 kV RMUs shall be connected. Accordingly, these DG sets shall be used as main source of emergency power supply for the tunnels.

All DG Sets shall be air cooled. DG Plant Room shall be acoustically treated to arrest the noise pollution as per CPCB Norm. DG Sets are envisaged to be operated in synchronization mode. Provision of PLC shall be done with Manual override facility, so that auto as well as manual synchronization can be done. PLC shall have in-built feature of synchronization, auto load sharing and auto load shading for the DG Sets.

Exhaust piping for the DG Sets shall be taken up to the highest point as per CPCB guidelines.

### **Uninterrupted Power Supply (UPS)**

The online UPS units (Uninterrupted power supply) will be installed with two-hour (120 minutes) autonomy period (Backup) as required to guarantee that following equipment can be supplied with uninterrupted power in case of main power failure:

- Tunnel Emergency Lighting
- Emergency Call system
- CCTV monitoring
- Signs escape route lighting and orientation signage other sign guidance
- Tunnel radio system
- Internal telephone system
- Public address & sound system

- Integrated tunnel control system
- Other emergency requirement

#### **Power Factor Control**

In order to achieve the economy due to improvement in P.F, it is proposed to install required capacitor banks on each bus of the substations switch gears Capacitors of required Capacity will be provided in capacitor panel / bank to take care of the reactive load and also meet the power factor of system 0.95 or better.

#### **Cabling / Wiring**

- **MV Power Cable**

Adequately sized PVC sheathed, XLPE insulated Aluminum conductor, 1100 V grade armoured power cables conforming to IS-7098 Part-I shall be provided for power distribution in pipe /cable trays. For outdoor application wherever required, cables shall be installed underground as per BIS and road crossing etc. shall be through already laid GI /RCC Hume pipes. Copper Conductor Cable shall be used up to 25 Sq.mm size and above 25 Sq.mm size, Aluminium conductor cable shall be used.

- **Wiring Installation**

Generally, the electrical wiring installation will conform to IS standard (IS: 732-1989). The complete wiring installation concealed or exposed will be installed in heavy gauge rigid steel conduit (black steel).

The wiring for light and small convenience power outlets within the portal shall be with PVC insulated (HRFR) copper conductor wires conforming to IS: 694. The lighting circuit wiring / point wiring shall be carried out with 2.5 Sqmm copper conductors while power wiring shall be carried out with 4 Sq.mm. copper conductor wires. Colour code shall be maintained for the entire wiring installation i.e. Red, Yellow and Blue for the phases and black for the neutral and green for earthing.

#### **Earthing System**

Safety in using electrical energy is of paramount importance considering its dangers The earthing system will be in conformity with the IS: 3043. All non-current carrying metal parts forming part of the electrical system shall be connected to the grounding system. The requirement of Indian Electricity Rules and statutory requirement of local Electricity Authority shall also be met fully.

- a) The earthing system is divided into two sections;

1	Substation Earthing (Copper)	a. Transformer neutral solidly earthed b. DG Set neutral solidly earthed
2	Protective Earthing (GI)	a. HT panel body earthing b. Transformer & DG Set body earthing c. LT Panels d. Power Panel e. Equipment

xlvi.

- b) Separate Earth stations shall be provided for all IT, electronic equipment and communication system.

### Lightning Protection System

Lightning protection is required only for the Portal Buildings. Since this is not a high-rise complex, sprawling over large area, conventional lightning protection system shall be provided. The lightning protection system shall consist of adequate lightning rods/ arrestors at terrace level, connected directly to earth station by 70 sq. mm single core PVC insulated flexible copper conductor. Required number of earthing Stations shall be provided for lightning protection.

#### 6.14 Tunnel Safety and Risk Assessment

Safety in tunnels requires a number of measures relating, amongst other things, to the geometry of the tunnel and its design, safety equipment, including road signs, traffic management, training of the emergency services, incident management, the provision of information to users on how best to behave in tunnels, and better communication between the authorities in charge and emergency services such as the police, fire-brigades and rescue teams.

Risk assessment is essential part of tunnel services and structural design. This has been considered in related to various incident scenarios which may occur during operation of the proposed tunnels. Risk analysis is based on risk rating of various incidents and their impact on the proposed tunnel structure and users

#### Vehicle related incidents:

Tunnels are being designed to carry traffic loading and there are events of varying probability which may affect safe operation of the tunnel.

- **Accidents**

Probability of occurrence of accident in an uni-directional tunnel is very unlikely. To reduce the probability of same to extremely unlikely event, alignment of the tunnels has been designed as straights with maximum grade of 4%. This will ensure high visibility to stopping vehicle / debris on road. It is also proposed to restrict the vehicle speeds to 80Kmph for the tunnels and enforce the same through speed detection cameras.

- **Breakdown and debris on road**

Risk of occurrence of such event is similar to accidents. Automatic incident detection system shall be implemented to reduce the impact of such event.

### **Prohibited Vehicles in Tunnels**

- Bicycles, tricycles or trishaws
- Tankers carrying diesel fuel
- Trailers hauling standard containers
- Vehicles higher than 5m

- **Oversize vehicles**

It is proposed to restrict entry of all oversized vehicles / consignments to tunnels to eliminate such risk.

- **Over height vehicles**

Sign boards with 5.0m height limit have to be provided at the tunnel approaches.

### **Non-Vehicle related incidences**

- **Animals in Tunnel**

It is proposed to provide guard rails along entire road to restrict entry of animals on the traffic lanes. Therefore, risk of such event is unlikely.

- **Vandalism**

Considering that this is an urban tunnel, it is necessary to provide for securitisation of likely entry points to the tunnels by pedestrians. Such a vandalism event may have very high impact on tunnel services. Therefore, control room shall be provided with automatic incident detection system to report stoppage of vehicles and pedestrian inside tunnel. Control rooms shall be manned 24x7 to register and act on such incidence. However, to eliminate risk of this high impact event, the SCADA software shall be capable of sending message to enforcement agency automatically with details of location.

- **Traffic Queues**

Risk of occurrence of traffic queues is unlikely considering adequate number of lanes have been proposed with adequate distances from tunnel entry/ exit points from proposed interchanges. However, event of traffic queuing is unlikely to impact on tunnel services. Environmental monitoring sensors are proposed to adjust level of tunnel services such as lighting and ventilation.

### Responding to collisions

The location, nature, severity of collisions to be assessed by the tunnel operating staff through OCMS and TCMS. The tunnel operating staff has to use TMCS (public address and break -in radio) to keep motorists informed of the event and actions that required to be taken. It is also required to place tunnel security staff at strategic points in the tunnel to ensure actions are heeded.



Ref: <https://www.bing.com/images>

### Scenario 1:

If the accident occurred in one lane only, then the movement of the traffic will be normal using the second lane and the downstream traffic of the accident lane will be merged to the second lane within the accident zone and once the vehicles crosses the accident zone, again the two lanes will be used normally from the upstream after the accident zone

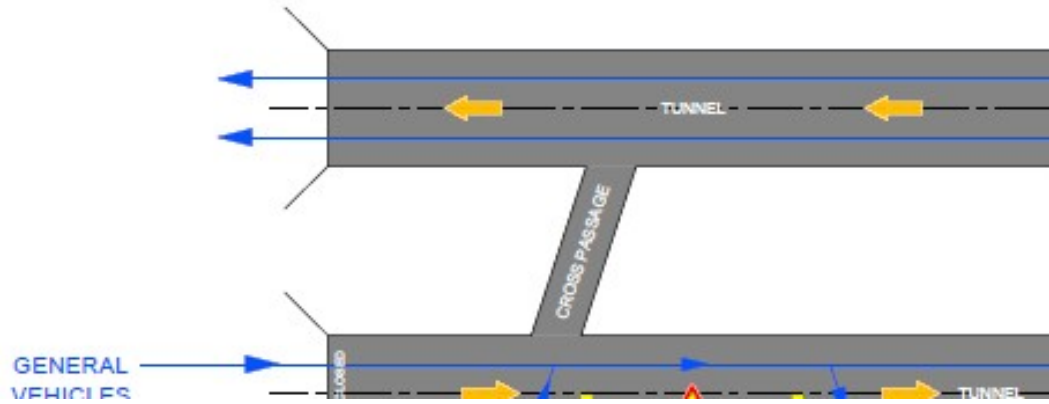

**Scenario 1**

**Scenario 2:**

If the occurrence of accident is in such a way that, both the lanes gets blocked and can't be used.

In this case, if the vehicles involved in the accident can be removed from the accident zone with the help of emergency vehicle reaching the spot using the emergency lane, and the time taken is short based on location of the accident, then its not required to close the tunnel in which the accident occurred.

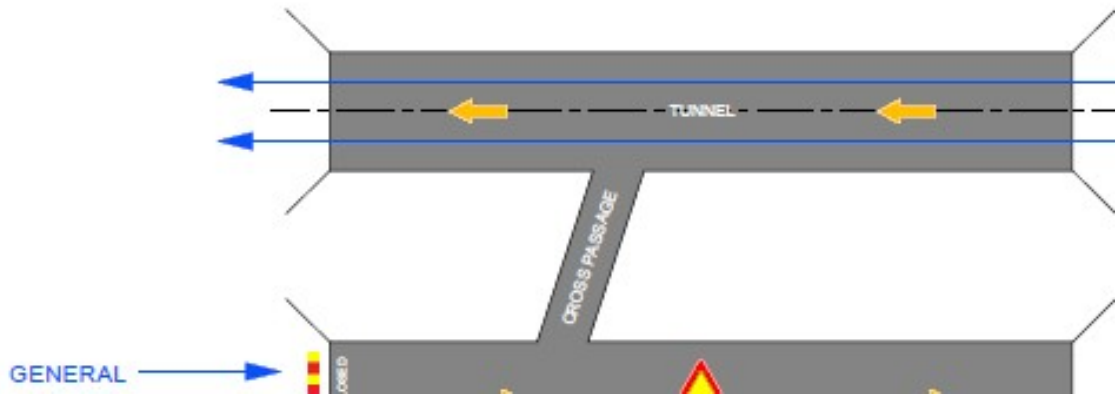

**Scenario 2**

**Scenario 3**

If the occurrence of accident is in such a way that, both the lanes gets blocked and can't be used.

In this case, if the vehicles involved in the accident can't be removed from the accident zone with the help of emergency vehicle reaching the spot using the emergency lane, then its required to close the tunnel in which the accident occurred and the emergency vehicle

should reach the accident spot using the non-accidental tunnel and further using the nearest Vehicular cross passage.

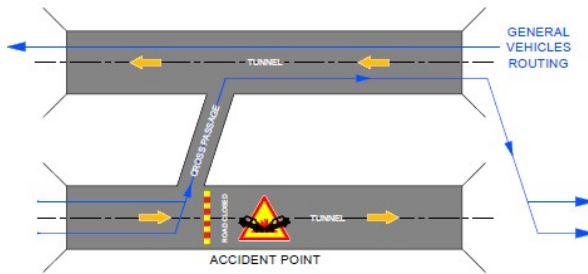

### Scenario 3

If there are no injuries but a blockage in the tunnel, the tunnel operating staff will immediately close that tunnel, directly inform the police services, and initiate an emergency protocol for evacuating vehicles and motorists under supervision of its own security staff, removing the damaged vehicle, clearing debris, and repairing damage to the road pavement.

If there are serious injuries the tunnel operating staff will close that tunnel; directly inform all emergency services and set-up command centre in the control centre building east (CCB-E) for joint emergency services and tunnel operating staff operations.

A serious accident in one tunnel may require a closure of the second tunnel to enable fast evacuation of pedestrians (without their vehicles), removing the injured and making the tunnel safe; the emergency lane of the tunnel can be used by the first responders to access the incident location in the tunnels.

### Transportation of dangerous goods

Transportation of “dangerous goods”(either toxic chemicals, or inflammable such as LNG ,LPG,ether,benzine, and paints )is totally prohibited and this should be posted on the approaches to the tunnels(All prohibited goods to be listed at the access road to the tunnels on boards).The tunnel operating crew will use the OMCS to recognize these vehicles and stop them before entry into the tunnels.

If the stopped vehicles are showing signs of escaping fluids, gases or fumes the emergency services will be notified through direct communication link and with the aid of tunnel security staff the vehicle will be re-routed.

The tunnel operating crew will identify vehicles transgressing prohibition orders and provide information to the police services.

**As per EU directive, NFPA and BD 78/99**

Service	Condition	Provision
<b>Structural Measures</b>	Twin tubes Mandatory where a 15-year forecast shows that traffic > 10000 veh./lane.	Twin/ Multiple uni-directional tunnels proposed
	Gradients less than 5% are mandatory	Gradients shall be restricted to 2.5%
	Emergency walkways are mandatory where no emergency lane is provided	Provision of emergency walkway is proposed
	Emergency exits every 200m are mandatory	Cross passages proposed at every 300m
	Drainage for flammable and toxic liquids is mandatory where such goods vehicles are allowed	Although such inflammable and toxic goods carrying vehicles will be rejected. Drainage provisions shall be made underneath the pavement
	Fire resistance of structures is mandatory where local collapse of structure may have disastrous effect	Complied by making such provisions
<b>Lighting</b>	Normal Lighting	Proposed as per CIE 88, 2004
	Safety lighting	Proposed as per CIE 88, 2004
	Evacuation lighting	Proposed as per NFPA 502
<b>Ventilation</b>	Mechanical ventilation if tunnel length exceeds 1000 m	Proposed longitudinal ventilation by providing axial fans and saccardo nozzles
<b>Emergency Stations</b>	Mandatory provision of emergency stations at 150m equipped with telephone and two fire extinguishers necessary	Provision to be made at every 100m.
<b>Fire Hydrant</b>	At every 100m	Fire main attached to water tank to be provided with supply point at every 100 m to match location of emergency station.
<b>Control Centre</b>	Surveillance of several tunnels may be	Two control centres shall be

	centralized into a single control centre.	provided at the two portals to respond to incident on entire stretch with provision of SCADA.
<b>Monitoring systems</b>	Video	CCTV cameras shall be provided along tunnels
	Automatic incident detection and/or fire detection	SCADA system connected to CCTV equipped with automatic incident detection system and response is proposed.
<b>Equipment to close tunnel</b>	Traffic signals before the entrances	The mandatory provision is to be complied by provision of boom gate, VMS, traffic signals before the portals controlled from Control centre
<b>Communication system</b>	Radio re-broadcasting for emergency services	Provisions made connected to SCADA system
	Emergency telephone for tunnel users	Provisions made connected to SCADA system
	Loudspeakers in shelters and exits	Provisions made connected to SCADA system
<b>Emergency power supply</b>	Mandatory	<p>The tunnels are to be connected by two separate electrical grid feeders with two separate supply feeders each (4 Connecting points) such that if a feeder fails the other automatically provide power to the tunnels.</p> <p>If both grid fails, the tunnels to have two diesel standby generators to provide power, with each capable of supplying power to operate essential equipment for the occupants to escape and for the recovery and emergency operations. The emergency generators shall be</p>

		tested during regulated timeslots to verify their readiness and performance.
<b>Fire resistance of equipment</b>	Mandatory	All tunnel fixtures and fitting shall be fire resistance compliant.
<b>Additional Provisions</b>	Drainage	It is proposed to provide sump and pumping arrangement to collect seepage/storm water at lowest point of tunnels and dispose the same to outside
	Leaky feeder cable	It is proposed to provide leaky feeder cable to enable use of mobile services within tunnels.
	Environmental monitoring sensors	It is proposed to provide environmental monitoring sensors to monitor visibility levels, air quality and smoke detection
	Linear Heat Detection	Linear heat detection is proposed through adoption of OFC cables cross looped to detect exact location of fire.
	Variable Message signs	It is proposed to provide VMS system attached to SCADA at control centre to enable safe tunnel operation.
<b>Emergency Response Vehicles</b>	Mandatory	<ul style="list-style-type: none"> <li>• Emergency Response vehicles: Rapid intervention vehicle with foam suppression system, CO2, and chemical fire extinguishers ,3 x fire hoses for connection to fire hydrants in tunnels.</li> <li>• Hiab trucks for lifting and transporting of breakdown</li> </ul>

		<p>vehicles</p> <ul style="list-style-type: none"> <li>•A minimum of two fully equipped ambulances with medical staff be stationed at the tunnel portals (One at east end and one at west end).</li> <li>•A traffic patrol vehicle / Motor cycle</li> </ul>
<p><b>Design for Evacuation</b></p>		<ul style="list-style-type: none"> <li>• The tunnel concrete structure is protected by thermal insulation boards to withstand a major fire of 4 Hours</li> <li>• Egress points for motorists (Not vehicles) from one tunnel to another are provided in "Cross passages" Spaced at every 300m.The doors to these cross passages are equipped with push-bars opening system (anti-panic handles) and are protected by 2-hour fire rated and to be pressurized to prevent smoke ingress with signposts.</li> <li>• Vehicle cross passages after every 2 pedestrian cross passages will be provided for the rescue/emergency vehicles to reach the</li> </ul>

		incident/event spot.
--	--	----------------------

**Responding to Fire:**

In an unfortunate event of a tunnel fire, The tunnels should be closed immediately (Upline tunnel and down line tunnel) to prevent outside vehicles entering the tunnel.

Notice be given through audible and visual alarm, emergency broadcast and other equipment in the tunnel to vehicles downstream of the accident point to quickly leave the tunnel and occupants of the vehicles upstream of the accident point to evacuate the fire tunnel through pedestrian/Vehicle cross passages in the tunnel or portals, leaving their vehicles behind.

In the a case of fire in the tunnel ,the use of vehicle cross passage be restricted to the emergency vehicles only as letting the general vehicles through vehicular cross passages will lead to possible blocking in the panic situation and will end up with emergency vehicles /fire fighting brigade not able to reach the fire spot for fire suppression ,extinguishing and containment.

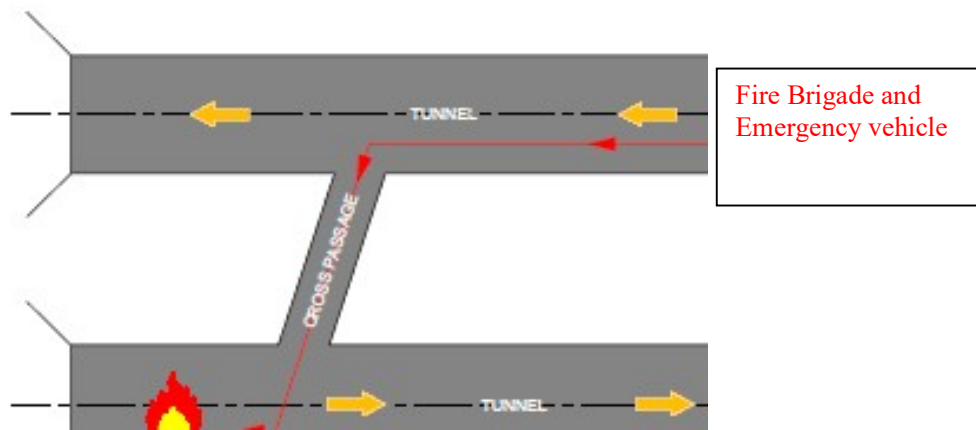

A serious accident in one tunnel may require a closure of the second tunnel to enable fast evacuation of pedestrians (without their vehicles), removing the injured and making the tunnel safe; the emergency lane of the tunnel, if not blocked, can only be used by the fire fighting and emergency vehicles and crew.

The fire - resistant rolling shutters at the vehicle cross passages be partially opened such that the smoke from fire tunnel not enter the non -fire tunnel in initial stage.

Opening the full shutter will allow fire smoke to enter the non-fire tunnel from the fire tunnel, thus posing a threat to personal safety.

In the event of a tunnel fire, selection of travel routes for rescue shall take into account the location of rescue vehicle, traffic congestion inside the tunnel, configuration of diverting lanes outside the tunnel etc.

The recommended travel routes are

Emergency lane either from Upstream or downstream of the fire spot if they are free (Might get blocked by general vehicles due to panic situation)

When the rescue vehicle come from upstream of the fire spot are blocked by other vehicles, then they can reach the accident point via the nearest Cross passage

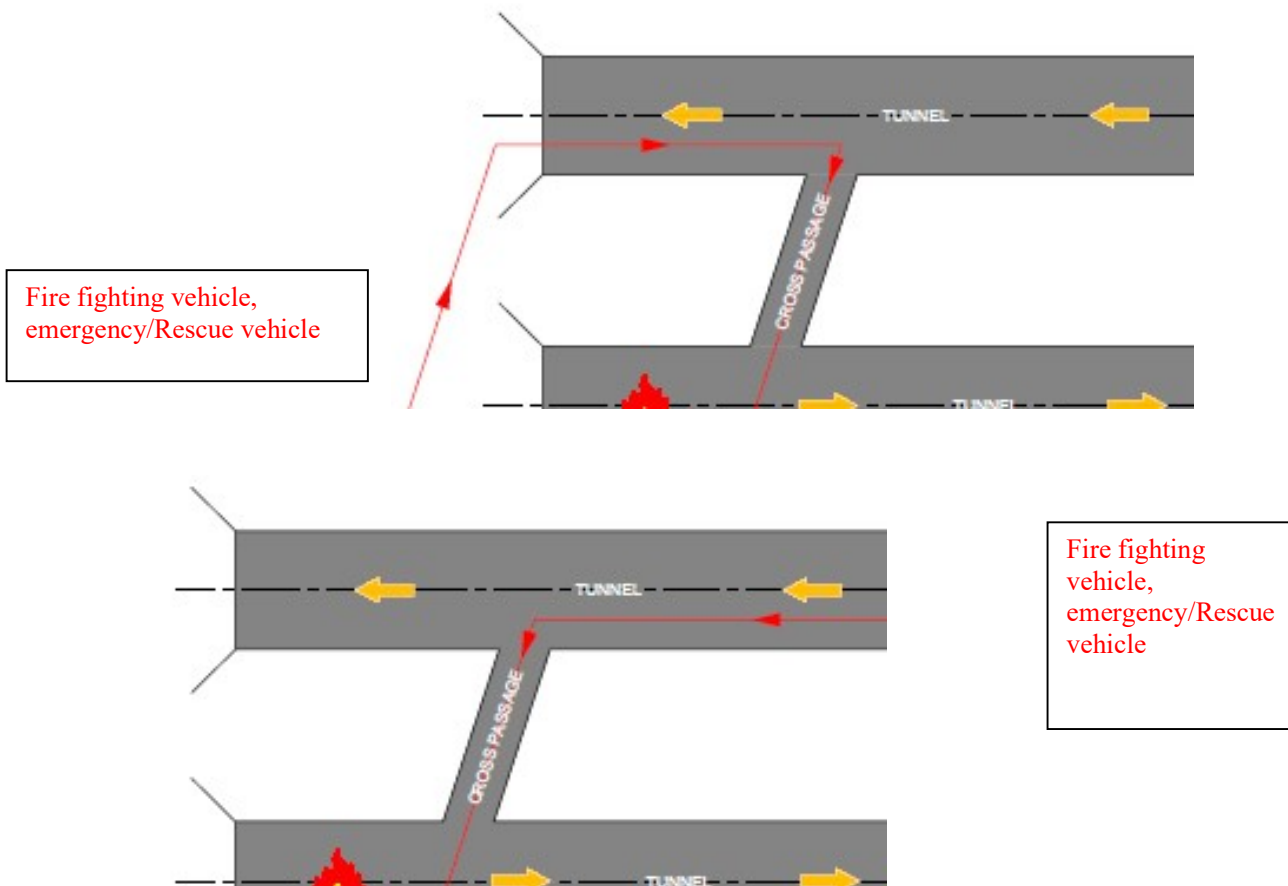

Ref: Investigation and analysis on the vehicle cross passages of Highway Tunnels - IOP Conference series: - Bin Li, Wei Li, Lianghong Lu and Shuai Liu

**Plant Monitoring and control system (PMCS)**

PMCS provides remote operation and monitoring of sub-systems including ventilation, traffic, lighting, communication, CCTVs, radio broadcast, telephone, fire detection, power supplies, security and access control etc. It provides a state-of-art technology and has 100% redundancy and other back-ups to ensure a failure at any point does not handicap the system.

### **Traffic Management and control systems (TMCS)**

TMCS provides traffic control and incident detection through traffic lights, boom gates, variable message signs, variable and speed limit signs, traffic counting, vehicle height detectors, CCTVs, Public address (PA) system and radio broadcast, and motorists emergency telephones.

### **Operation Monitoring and Control system (OMCS)**

OMCS integrates the two system and is also the main processing and data storage centre for tunnel operations.

All communications in the tunnels – including the motorists emergency telephones – will be installed in enclosure providing 2-hr fire rating.

### **Security Events**

#### **Design for security events**

The OMCS, which includes two-way, hard wired communications to all the emergency agencies, will be used for dealing with security threats. Initial communication will be with (or by) the emergency services and arising from these a decision will be made on establishing a command centre, called Control centre building (CCB-E). Should the focus of attention be to the west, the tunnel operations crew will consider moving to the command centre, called control centre building west (CCB-W).

The tunnel operating staff will include security officers who will routinely patrol the tunnels and can respond to low – level emergency situations.

A card locking mechanism, or similar, along with CCTV will be installed on doors to operational rooms and plant rooms, and cross passages to keep these secure from unauthorized entry and control movement of personal.

## RESPONSES TO SECURITY EVENTS

Security risks range in severity from uncoordinated incursions into the tunnels, minor criminal damage, threat of terrorism, organized incursions by terrorists into the tunnels, incendiary fires, and explosions. The tunnel operating staff and police services should have a protocol for grading risks. The tunnel's security team shall be trained to recognize potential security threats in the tunnels.

High-level risks concerning terrorism will be communicated by the police services using hard-wired line: Impact of such terrorism events on tunnel operation would be disastrous and would require immediate action by local police. The method of reducing risk of such event shall be discussed with the authority at the time of execution.

If terrorist activities are detected within the tunnel the information shall be passed to the police services.

Explosions are likely to initiate fires, impact damage and shockwave damage. Although the tunnels are made to compliance of NFPA-502, however, in the event of explosions shock waves are likely to produce localized damage to the concrete structure of the tunnel and extensive damage to fixtures and fittings located above and alongside of the roadways. These are likely to be brought down thus hindering both evacuation and immediate recovery efforts.

Damages to the concrete structures will likely require inspection from the experts and certification before re-opening the tunnel to public.

### Earth Quakes

#### Designing for earth quake events

A maximum seismic force provided in Indian Standard Code 1893:2002 with the zone factor for Mumbai of 0.16g. Seismic forces are then applied.

#### After an earth quake event

A seismic event will occur without warning and it is likely that vehicles will be present when an earth quake strikes. The magnitude of the earth quake may not become immediate

apparent, nor if there is a risk from aftershocks. On examination from CCTV footage and environment to ascertain magnitude of the earthquake, the tunnel operations crew will respond as follows:

- An earthquake which releases seismic energy below the Indian standard is likely to have an impact on the functioning of the tunnels and evacuation of vehicle is expected to be straight forward normal circumstance channel.
- If the seismic energy released by the earthquake is close to the Indian standard, Tunnel communications and emergency power supply are expected to survive but fallen signage will be partially blocking the roadway. The tunnel operating staff will inform motorists whether to evacuate by vehicle or by foot. Should the ventilation fan the tunnel operating staff will require to assess build up- of noxious gases on the evacuation procedure.
- If the seismic energy released is more than the Indian standard will most likely result in communications, loss of OCMS and blockage of escape routes. At this seismic level widespread devastation is expected and this will influence resources that can be brought for recovery of motorists from the tunnel.

#### **RESPONSE TO A CYCLONE EVENT**

The tunnel operation team must monitor live data from Indian Meteorological department (IMD) to be informed of any cyclone together with an estimate of its disruptive power. The management of tunnel operations will communicate of its decision to shut down the tunnel using the direct communication link with the emergency agencies' shut down will proceed using OCMS and its own security officers will check that the barriers gates are in position and the tunnel evacuated. The OCMS will also confirm that operating plant is in a state of readiness to deal with influx of water.

The decision to shut down the tunnel will be made well below limits of maximum wind speed and tidal surge, such that the evacuation of motorists prior to closure of the tunnels should not present a problem.

Recovery operations after a cyclone will most likely be similar to recovery after a flood event. Wind damage is likely to be at the portal event.

## FLOODING

### Design for a flood event

The design of the two tunnels has taken into consideration the following:

- In front of ramp each ramp leading into tunnel, there will be a “Hump “to prevent surface flood water from entering the tunnel. Water overflowing this hump will be caught in a crossroad drainage channel.
- If the flood of water overwhelms the channel, due to road camber it will collect at the road side and flow into the catch pits spaced every 50m. From the catch pit the water will enter the sump pits located at the portals from where it will be pumped out.

### Recovering from flood event:

It is anticipated that there will be sufficient warning of a flood whether by cyclone, tsunami, of rainstorm storm to close the tunnel and evacuate all vehicles and personals. Tunnel operating staff working in the service building will work accordingly to the emergency procedures and will have sufficient time to evacuate before height of water increases in the tunnels to the operating rooms.

After such an event a geotechnical and structural engineer to check embankments, slopes and the tunnels for damage and instability. Structures such as ramps leading into the tunnel, service building are to be checked. An MEP engineer shall initially assess whether all power circuits have been made safe. All initial checks are aimed at safety of those charged with recovery options.

Recovery responders working with a team of Engineers (Civil, Mechanical and Electrical) will initially prepare a plan for pumping-out water from the tunnel, removal of debris, cleaning washing and damage assessment. The plan will address a” staged “recovery with area’s most easy access to (Tunnels)being tackled first and the area that are more difficult to access (Utility box, equipment rooms etc.), last.

During the recovery phase the potential for electric shock will be continuously evaluated by a qualified person.

## ESCAPE OF DANGEROUS GASES

The tunnels will be equipped with a “Pollutant Monitoring and control system” which will detect both pollution levels and presence of flammable/ explosive gases and fumes. Output from the measuring devices will be registered by the OMCS and the tunnel operating crew will control the ventilation fans through the PMCS. Operation of tunnel ventilation under fire conditions, detection of smoke, detection of explosive /flammable gases and fumes, and other conditions will be described in the ventilation report.

## TRANSPORTATION OF DANGEROUS GOODS

Transportation of “dangerous goods”(either toxic chemicals, or inflammable such as LNG ,LPG,ether,benzine, and paints )is totally prohibited and this should be posted on the approaches to the tunnels(All prohibited goods to be listed at the access road to the tunnels on boards).The tunnel operating crew will use the OMCS to recognize these vehicles and stop them before entry into the tunnels.

If the stopped vehicles are showing signs of escaping fluids, gases or fumes the emergency services will be notified through direct communication link and with the aid of tunnel security staff the vehicle will be re-routed.

The tunnel operating crew will identify vehicles transgressing prohibition orders and provide information to the police services.

## VEHICLES USING CNG

The risk of a gas explosion, rather than fire, is dependent on the quantity (kg) of gas and emission rate of the gas from its container (Kg/Sec), in relation to the cross-sectional area and ventilation velocity in tunnel. As the tunnels are 2 lanes plus an emergency lane with a capable ventilation system and because transportation of dangerous goods (LNG tanker) is not allowed, the risk of LNG explosion is small from motor-car vehicles using LNG.

In the Event of a fire in the tunnel – whatever the fuel – the focus of the tunneling operating staff ‘s immediate actions will be to stop vehicles from entering the tunnel and evacuation of the effected tunnel. Limiting rapid fire spread and eventually firefighting using emergency services.

## Chapter 7-Social Impact assessment

### 7.1 Social impact assessment (SIA)

Social Impact Assessment is a methodology to review the social effects of infrastructure projects and other developments

#### OBJECTIVES

Establishing a technical, economic and financial viability of the project; and Preparing a Detailed Project Report for the construction of twin tunnel with provision of capacity augmentation for the project stretch

#### SCOPE OF THE SOCIAL IMPACT ASSESSMENT

The proposed project traverses through forest area, except for 5% in residential area. To understand the socio-economic impact of proposed project on the people, a social impact assessment was carried out. The social Assessment is based on the result of consultation and baseline socio-economic survey. Based on findings of social assessment report and consultation, a detailed Social Impact Assessment Report is prepared and attached to this DPR as Annexure.

Social survey of the project is the first stage to assess the likely impacts of development project on the properties, people and key stakeholders within the COI. Survey includes identification of broad categories of affected properties, the impact of the project on the project-affected people (PAPs) and it focuses on both beneficial and adverse social impacts. The scope of survey includes identification of problems and issues related to the project and people dependent on them for their livelihoods. Further, the scope is also extended to chalk out the following:

A mechanism to identify the opportunities, constraints, impacts and social risks associated with policy and project design.

An approach to identify and mitigate the potential social risks, including adverse social impacts, of the project.

Providing various feasible options with minimum social risks, that would be mitigated at a later stage.

One of the relevant scopes of the project includes preparation of Resettlement Action Plan. This report is assessment of the social impacts of the population in the project area/ project influence area, keeping in mind with the requirement of the terms of reference (TOR).

#### METHOD AND TOOLS USED FOR THE STUDY

The field research includes preliminary social survey of the project affected persons and properties within the proposed alignment and

- Data Collection from Primary Sources
- Data Collection from Secondary Sources

Social development objectives of the project.

Scope of social impact assessment

Proposed Alignment

Need for Social impact assessment

Identification of critical segments

Stake holder consultation

Development of socio-economic indicators

**Socio economic profile of the project area covering**

- Physical features and district profile on east and west sides of the project
- Demographic profiles of the districts
- The social services
- Economic features
- Social and Demographical profile of the affected villages

**EVALUATION OF SOCIAL IMPACT AND LAND ACQUISITION**

**Introduction**

The Social Impact Assessment at this stage aims to record impact on the community and settlement in order to prepare the resettlement and rehabilitation framework and provide the basic information. The thrust of this integration is to minimize the adverse impacts with the best possible socio-economic mitigation measures and engineering solutions at the most appropriate cost.

It is Important to note that, Govt. of Maharashtra considering the present traffic scenario in Mumbai and Thane city vis-à-vis the growth rate of Mumbai and surrounding areas have decided to take appropriate measures for decongesting the traffic in Mumbai city, thereby bring reduction in pollution and accident rates and to provide a dedicated corridor for the heavy and light through traffic from/towards west and north directions proceeding/coming from south directions. At present there is no direct and continuous route available for long-distance traffic on the outskirts of Mumbai and Thane. All the traffic is passing, through cities with local traffic and giving rise to pollution and accidents. This decision was also taken due to the strategic importance of the project and its major role of connecting Eastern Express Highway and Western Express Highway and other local roads to facilitate local and Through Traffic.

Hence, the present exercise for assessing social impacts was done considering proposed alignment. The impacts on population, properties and assets have been examined for the proposed alignment.

The present exercise, as a part of social assessment, will explore the potential impact on the population as well as on the properties i.e., impact assessment within 70 mtrs of proposed ROW.

**PROPERTIES LIKELY TO BE AFFECTED**

The properties which are likely to be affected by the proposed project are primarily screened at this stage by using structured questionnaire (attached in **Annexure-3.1**). These properties include houses, shops, offices, religious establishments, markets, community halls or any other structure. It has been attempted to get the details of various structures that are located within the proposed COI of the project.

The social survey, conducted within COI indicates that considering the length and breadth of proposed project stretch there are marginal number of structures falling within the proposed twin tunnel. The survey shows that about 247 structures are falling within COI of proposed right of the way on the alignment. The following



sections deals with the details of the affected structures. The number of properties and its alignment is depicted in **Table 3.1**.

**Table 3.1: Number of Affected Structures within Corridor of Impact**

Sl. No.	Properties	No. of Structures	Total %
1	Private Properties	221	89.47
2	Community Property Resources (CPRs)	26	10.53
<b>Total</b>		<b>247</b>	<b>100.00</b>

*SOURCE: SOCIAL SURVEY, FEBRUARY-2019*

### **OWNERSHIP OF THE PROPERTIES LIKELY TO BE AFFECTED**

The total numbers of properties documented have been analyzed under different categories in terms of its uses, such as private, religious, public/ govt. etc. These divisions have been made according to their use and occupancy. Out of the total 247 (number of properties) that are likely to be affected, 221 are private properties (properties that are owned by individuals and do not have govt. or community ownership). During the social survey, few of the households are reluctant to respond, hence those household were unaccounted in the survey and it is noted here that 221 private properties



have been enumerated. 15 are Government properties, while 1 religious property, which include the temple. Moreover, 10 community properties are also likely to be negatively impacted. The property falling within the corridor of impact as per its type of ownership has been documented in **Table 3.2**. The details of affected structures are attached in **Annexure-3.2**.

**Table 3.2: Ownership of Properties likely to be affected**

Sl. No.	Type of Properties	No. of Structures	Total %
1	Private	221	89.47
2	Religious	1	0.41
3	Government	15	6.07
4	Community	10	4.05
<b>Total</b>		<b>247</b>	<b>100.00</b>

*SOURCE: SOCIAL SURVEY, FEBRUARY-2019*

### **PRIVATE PROPERTIES TO BE AFFECTED**

The total number of private properties likely to be affected due to the project is estimated to be 221 in number. These private properties are residential, commercial, or residential-cum-commercial, factory and kiosk. It was revealed in the social survey that most of the structures along the project are Residential in nature (91.41%) followed by 9(4.07%) are commercial, 5 (2.26%) are kiosk, 3 (1.36%) are factory and 2 (0.90%) are residence-cum-commercial structures as shown in **Table 3.3**.

**Table 3.3: Type of Private Properties Likely to be affected**

Sl. No.	Type of Private Property	Total	Total %
1	Residential	202	91.41
2	Commercial	9	4.07
3	Resi-cum-commercial	2	0.90
4	Factory	3	1.36
5	Kiosk	5	2.26
<b>Total</b>		<b>221</b>	<b>100.00</b>

*SOURCE: SOCIAL SURVEY, FEBRUARY-2019*

#### **TYPE OF CONSTRUCTION OF THE STRUCTURES**

The majority of constructed structures, which are likely to be impacted within the corridor of impact, are semi-permanent 145 (65.61%) followed by temporary 67 (30.32%), permanent 5 (2.26%) and 4 (1.81%) are permanent. The details of the type of constructions of the structures are summarized in the **Table 3.4**.

**Table 3.4: Type of Construction of Structures**

Sl. No.	Type of Construction	No. of Structures	Total %
1	Temporary Structure	67	30.32
2	Semi-Permanent Structure	145	65.61
3	Permanent Structures	4	1.81
4	Kiosk	5	2.26
<b>Total</b>		<b>221</b>	<b>100.00</b>

*SOURCE: SOCIAL SURVEY, FEBRUARY-2019*

#### **LEGAL STATUS OF THE OWNERSHIP OF THE PROPERTIES/ STRUCTURES**

The analysis of the ownership status of the affected persons was done considering the proposal of the twin tunnel with consideration of expected traffic volume.

It is evident from the data that inviting significant impact on titleholders, which is coming within 70 mtrs wide tunnel alignment. In the alignment area the proposed project will need significant amount of land acquisition & will have impact on 70 mtrs width of land all along the alignment. In this stage of the only structures owners were identified in the assessment and it is found that nearly 2.71% are titleholder, 33.04% are encroacher and 64.25% affected persons are squatters as detailed in **table 3.5**.

**TABLE 3.5: ENTITLEMENT OF PROPERTIES**

Sl. No.	Entitlement of Properties	Total	Total %
1	Title Holder	6	2.71
2	Encroacher	73	33.04
3	Squatters	142	64.25
<b>Total</b>		<b>221</b>	<b>100.00</b>

*SOURCE: SOCIAL SURVEY, FEBRUARY-2019*

#### **NATURE OF IMPACT**

Demolition of structures shall lead to either of the two impacts - livelihood loss or loss of living place. The detail information, collected during survey, reveals that 91.40% households are of residential structures and 8.60% households are of commercial place, who are losing their livelihood, are being affected. It can be noted here that the households with resi-cum-commercial structures, factory and kiosk has also been considered under the category of impact on livelihood as they are also carrying out commercial activity at their place (**table 3.7**).

**TABLE 3.7: NATURE OF IMPACT**

Sl. No.	Nature of Impact	No. of Structures	Total %
1	Residence loss	202	91.40
2	Livelihood loss	19	8.60
<b>Total</b>		<b>221</b>	<b>100.00</b>

*SOURCE: SOCIAL SURVEY, FEBRUARY-2019*

#### RELIGIOUS PROPERTIES LIKELY TO BE AFFECTED

The impact on religious structure is generally considered as an area of concern due to its association with the religious sentiments of the people. The total number of religious properties likely to be affected due to project is 1, which includes *Temple*. **Table 3.8 (Annexure 3.3)**.

**Table 3.8: Religious structures**

Sl. No.	Type of Religious Property	No. of Structures	Total %
1	Temples	1	100.00
<b>Total</b>		<b>1</b>	<b>100.00</b>

*SOURCE: SOCIAL SURVEY, FEBRUARY-2019*

#### PUBLIC/COMMUNITY PROPERTIES (CPRs) LIKELY TO BE AFFECTED

It is found during social survey that around 10 public/community properties are likely to be affected due to the proposed twin tunnel. The details of such properties are summarized in the **Table 3.9 (Annexure 3.3)**.

**Table 3.9: Type of Public/Community Properties likely to be affected**

Sl. No.	Type of CPRs	No. of Structures	Total %
1	Tata Power House B/W	1	10.00
2	Community Boundary Wall	4	40.00
3	Greenery Orchard	1	10.00
4	Toilet	3	30.00
5	Society Canopy	1	10.00
<b>Total</b>		<b>10</b>	<b>100.00</b>

*SOURCE: SOCIAL SURVEY, FEBRUARY-2019*

#### GOVERNMENT PROPERTIES LIKELY TO BE AFFECTED

Collected data shows that there are 15 government properties that are likely to be affected due to the construction of the proposed twin tunnel. The details of such properties are summarized in the **Table 3.10 (Annexure 3.3)**.

**Table 3.10: Type of Government Properties likely to be affected**

Sl. No.	Type of Government Properties	No. of Structures	Total %
1	Yatri Shed	3	20.00
2	Forest Building/ Forest Booth	3	20.00
3	Government Building	2	13.31
4	Library	1	6.67
5	Bus Depo Ticket Booth	1	6.67
6	Fish Market	1	6.67
7	Arogya Kendra (Health Center)	1	6.67
8	BST Chowki	1	6.67
9	Budh Vihar (Rel)	1	6.67

Sl. No.	Type of Government Properties	No. of Structures	Total %
10	Hand pump	1	6.67
<b>Total</b>		<b>15</b>	<b>100.00</b>

*SOURCE: SOCIAL SURVEY, FEBRUARY-2019*

### **SOCIAL PROFILE OF THE PAPs ALONG THE PROPOSED PROJECT**

The purpose of our survey was to create a broad database of the affected properties as well as the project-affected persons (PAPs) in order to understand the social profile of the project-affected area. It helps to appraise the positive as well as negative change in the life style of the communities in the project influence area due to implementation of the project as an external intervention.

Based on the primary data collected during census survey, an assessment of the social profile of the affected population has been outlined in the following paragraphs.

#### **Religious Category of PAHs along the Proposed Project**

Social customs and tradition play a major role in determining the socio-economic development as well as occupational pattern in the influence area, keeping this in mind an initial analysis has been conducted taking into account the religious profile of the PAPs within the corridor of impact. In the proposed project majority of the PAHs belong to Hindu religion, i.e. 76.02% followed by Buddhist population of 18.10%, Muslim population 8 (3.62%) and 1 (0.45%) are Jain. However 1.81% of households did not respond or not present at the time of survey. This trend shows that Hindu communities dominate the proposed project, which is also reflected in the type of religious structure along the project, where the worship places located on the project are temple belongs to Hindu communities. **Table 3.11** delineates the religious cluster of the affected Households.

**Table 3.11: Religious Categories of PAHs along the Project**

Sl. No.	Religious Group	No. of Households	Total %
1	Hindu	168	76.02
2	Muslim	8	3.62
3	Buddhist	40	18.10
4	Jain	1	0.45
5	NA/NR	4	1.81
<b>Total</b>		<b>221</b>	<b>100.00</b>

*SOURCE: SOCIAL SURVEY, FEBRUARY-2019*

#### **Social Category of PAHs along the Proposed Project**

The data indicate that majority of PAHs belong to SC Caste. Out of total PAHs, 58.37% belong to Schedule Caste followed by General (28.05%). There are about 8.60% and 3.17% households belonging to Other Backward Caste (OBC) and Scheduled Tribes (ST) respectively. However, 1.81% of households did not respond or not present at the time of survey and the details are given in **Table 3.12**.

**Table 3.12: Social Stratification of PAPs along the Project**

Sl. No.	Social Category	No. of Households	Total %
1	SC	129	58.37
2	ST	7	3.17
3	OBC	19	8.60
4	General	62	28.05
5	NA/NR	4	1.81
<b>Total</b>		<b>221</b>	<b>100.00</b>

SOURCE: SOCIAL SURVEY, FEBRUARY-2019

#### Type of family of PAHs along the Proposed Project

The project influence area is dominated by Nuclear families with 89.59% of the total affected households, in comparison to joint family, which is 8.60%, when analyzed, considering the proposed project within 70 mtrs. **Table 3.13** shall be referred for details.

**Table 3.13: Type of family of PAHs along the Project**

Sl. No.	Type of Family	No. of Households	Total %
1	Joint	19	8.60
2	Nuclear	198	89.59
4	NA/NR	4	1.81
<b>Total</b>		<b>221</b>	<b>100.00</b>

SOURCE: SOCIAL SURVEY, FEBRUARY-2019

#### Occupation Pattern in the family along the Proposed Project

The project is dominated by families involved in labour activities. Out of total 221 affected households within 70 mtrs of project width about 33.03% (73 in number) of them are engaged in labour for their income. 24.89% are engaged in Service followed by 14.03% engaged in business for their livelihood, 31 (8.07%) households are engaged in labour activity and 50 (13.02%) of households did not respond or not available during survey. Very few families i.e. about 9 (2.34%) fall in professional category for earning the livelihood is very low. **Table 3.14** gives the details.

**Table 3.14: Occupation Pattern**

Sl. No.	Occupation	No. of Households	Total %
1	Service	55	24.89
2	Business	31	14.03
3	Agriculture	0	0.00
4	Labour	73	33.03
5	Housewife	12	5.43
6	Old Person	38	17.19
7	Unemployed	4	1.81
8	NA/NR	8	3.62
<b>Total</b>		<b>221</b>	<b>100.00</b>

SOURCE: SOCIAL SURVEY, FEBRUARY-2019

#### Vulnerable Groups along the Proposed Project

The Social Impact Assessment identifies the vulnerable population in order to minimize the adverse impact and provide adequate mitigation measures. An assessment was made to bring out the vulnerable PAPs (SC, ST, Below Poverty Line families, Women-headed Households and households headed by physically handicapped persons). Their distribution on the stretch in terms of absolute numbers and percentage are given below.

The data reveals that out of 221 affected households, 95 households are vulnerable households are coming within the COI. Out of 95 households, 129 are Schedule Caste, 7 households belong to ST, 7 households belong to WHH, and 1 household is BPL category. It shall be noted here that the number of BPL and WHH mentioned in the below table does not include those who fall under SC and ST category to avoid the repetition of data. Refer **Table 3.15** for the details of vulnerable groups:

**Table 3.15: Vulnerable Groups along the Project**

Sl. No.	Vulnerable Category	No. of Households	Total %
1	SC	129	58.37
2	ST	7	3.17
3	BPL (Excluding SC, ST)	1	0.45
4	WHH	7	3.17
<b>Total Vulnerable Category</b>		<b>144</b>	<b>65.16</b>
<b>Non Vulnerable Category</b>		<b>77</b>	<b>34.84</b>
<b>Total Household</b>		<b>221</b>	<b>100.00</b>

*SOURCE: SOCIAL SURVEY, FEBRUARY-2019*

#### **Total Number of PAPs**

At this stage of study, only those households are included in the surveys, who are losing their structures only. The analysis of the social survey shows that all the affected **221** households comprise of about 892 PAPs, who are likely to be affected directly or indirectly by the project within the corridor of impact. This figure does not include the affected persons of those households who were not available for survey and the family members or not responded. At few locations people were even reluctant in giving the details of their families.

Of the total number of PAPs, 52.35% are males and 47.65% are females. The detail of number of PAPs enumerated has been mentioned in **Table 3.16**.

**Table 3.16: Number of PAPs along the Project**

Sl. No.	Category	No. of PAPs	Total %
1	Male	467	52.35
2	Female	425	47.65
<b>Total</b>		<b>892</b>	<b>100.00</b>

*SOURCE: SOCIAL SURVEY, FEBRUARY-2019*

#### **LAND ACQUISITION DUE TO THE PROPOSED TWIN TUNNEL PROJECT**

The improvisation of the twin tunnel project is to be done within 70 mtrs of PROW. The social assessment of the project was done within defined corridor of 70 mtrs, so that if required, the impact on properties, population and other assets can be considered with ease. Hence, the calculation of land acquisition was done considering tunnel configuration within 70 mtrs of ROW is also examined.

The analyzed keeping in mind the large scale of displacement of people along the proposed tunnel at different locations and accordingly the land requirement was also examined and was calculated for the 70 mtrs of proposed ROW.

Moreover, calculation of land acquisition for twin tunnel estimated and incorporated and presented in **Table 3.17** for the details of PROW and required land intake at various locations and for various options. The land, which has to be acquired for any of the above-mentioned options, includes private as well as government land.

**Table 3.17: Land Acquisition details for Various Options**

Land Acquisition Proposed	Total (In Sq. mtrs.)	area Total (In Hectare)
Private Land from 0+000 to 11+838	144613	14.4613
<b>Total Area</b>	<b>144613</b>	<b>14.4613</b>

#### **REHABILITATION OPTION**

the social survey also included the information from the private structure owners regarding their rehabilitation option. out of total 221 private structures owners majority opted for equivalent property for property lost. rest of the affected property owners opted for employment during construction, equivalent property for property lost and partly cash compensation and partly assistance as presented in **table 3.18**.

**TABLE: 3.18: REHABILITATION OPTION**

Sl. No.	Rehabilitation option	No. of Household	Total %
1	Equivalent property for property lost	221	100.00
<b>Total</b>		<b>221</b>	<b>100.00</b>

SOURCE: SOCIAL SURVEY, FEBRUARY-2019

#### **CONCLUSION**

The socio-economic analysis of the project affected persons reveals their opinion the project corridor. Construction of the proposed project will lead to the involuntary resettlement of PAPs. It is of utmost importance to resettle and rehabilitate them as per the provisions of RFCTLARR Act-2013 and RFCTLARR (Maharashtra) Rules-2014. Affected people shall be consulted at every stage of the project planning and implementation. Their worries and suggestions shall be taken into account and the negative impacts shall be mitigated.

---

### **Chapter 8-Environmental Impact assessment**

The Proposed project is about 11.8 km from Borivali to Thane passing below ground SGNP will not require any environmental clearance (EC) from the central or the state level authorities. The project needs only forest clearance from forest department and wild life clearance from NBWL which is currently under process.

Dr N C Kankal retd.Senior Principal Scientist from NEERI ,Nagpur has prepared the detailed report on EIA/EMP for the proposed project .

This report is being submitted along with the DPR as annexure.



## Chapter 9 -Financial Analysis

### FINANCIAL ANALYSIS: SGNP

#### Build Operate and Transfer (BOT)

##### 1.0 Introduction and Background of the Project

AECOM carried out financial analysis after finalization of detailed engineering and cost estimation of the project. Series of discussions were held with MMRDA officials while exploring possible alternative options to be considered during finalization of input parameters for financial analysis. It was informed by MMRDA that project shall be implemented through loan from bank and certain percentage of project cost shall be provided by private investor as equity. Toll shall be imposed on the corridor and collected revenue shall be used for repaying the bank loan and equity by private investors under BOT-Toll settings.

Guideline for determination of toll is set as per the “National Highways Fee Rules, 2008”. In the Toll policy two sets of toll rates are suggested for following two categories 1. Roads and normal cross drainage structures and 2. Major bridge and special structures including flyovers, ROB, RUB etc.

Toll rates derived using actual length of road and structure portion strictly following guideline of “National Highways Fee Rules, 2008”. Therefore, it was decided in consultation with MMRDA official that few alternative options shall be explored to restrict the estimated toll rate within practical range compatible with prevailing toll rates of national highways. It was decided that the total cost towards financing of the project shall be 30% from private investor as equity and remaining 70% from bank as debt. Findings of the detailed financial analysis for selected option are summarized below.

##### 2.0 Financial Analysis for selected option—BOT

###### 2.1 Total Project Cost (TPC)

The total project cost of entire stretch for SGNP including Land acquisition, Resettlement & Rehabilitation, Utility shifting, departmental supervision, Environmental Program Management (EMP) cost, Toll Plaza Construction Cost, Contingencies, Insurance, IDC, etc. is Rs 14754.6 crore vide Table 2.1. The construction is assumed to commence in 2023 and will be completed by the end of 2027. The new corridor will be opened for traffic in 2028. The broad components of construction cost are as follows:



Detail Project report for Construction of 11.85km long twin tube, 2 lanes + 1 emergency lane each highway tunnel for connecting Thane on Eastern Express Highway to Borivali on Western Express Highway in the state of Maharashtra

**Table 2.1: Construction Cost of the corridor**

Sources		Uses	
Equity (including finance costs)	3,825.3	0.0	Costs - design & development
Grant dispersal	0.0	12,751.0	Costs - civil construction
Debt	8,925.7	0.0	Costs - other
Compounded interest during construction	2,003.6	0.0	Contingency
		0.0	Insurance
		0.0	Financing costs
		2,003.6	Interest during construction
<b>Total</b>	<b>14,754.6</b>	<b>14,754.6</b>	<b>Total</b>

Source: Financial Model

The phasing of construction has been considered as 10% in each half year to distribute IDC uniformly; similarly, instalment profiles given in Table 2.2.1A.

**Table 2.2.1A: Phasing Profile of Construction**

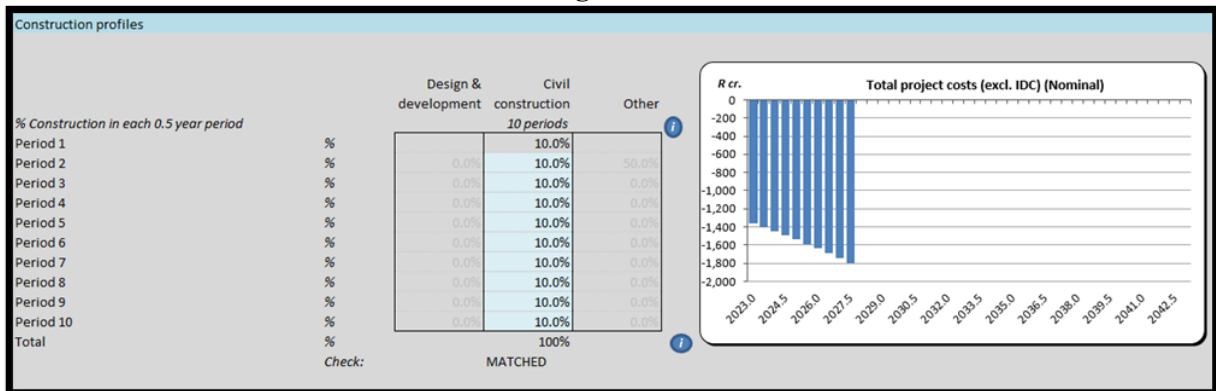

Source: Financial Model

## 2.2 Maintenance Cost

The life-cycle cost depends on the time period over which operations and maintenance costs will accrue. This time period is termed as “design service life.” The specific time period selection—typically made with consideration for wear and aging of materials. But overloading is an important issue in determining maintenance cost. The functional deficiency of a structure leads to higher user costs. These functional deficiencies may cause higher vehicle-operating costs because of such factors as detours, lost travel time, and higher accident rates. New corridor maintenance work cost includes routine maintenance, rehabilitation, or replacement. The total maintenance costs of the new are two types - Periodic and Routine Maintenance. Both the routine and periodic maintenance are to be undertaken during the entire project period.

### 2.2.1 Routine & Major Maintenance Cost

The annual maintenance cost of entire corridor including major maintenance cost of structure has been considered at Rs. 2.0 lakh per lane per km which is approximately Rs. 14.16 Cr as per 2022



price level. These costs mainly cover the health monitoring cost, dewatering, painting and minor surface maintenance. A regular or periodic inspection is needed to maintain the entire corridor along with the structure and for major maintenance an engineering consultant may be needed or to be appointed by the project authority, MMRDA. The total maintenance cost along with the consultant fees have been clubbed together to routine maintenance at 2022 price level including Periodic or Heavy Maintenance cost of the new structure.

## **2.3 Cost Recovery**

### **2.3.1 Tolling zone**

#### **2.3.2 Tolling Location Criteria**

The location of a toll plaza can have a significant effect on both its operational performance and its environmental impact. The following factors need to be taken into effective consideration to determine the optimum location of a toll plaza:

- Visibility to approaching traffic
- Horizontal and vertical alignment of main line
- Proximity to Intersections
- Safety
- Security of toll revenues and transfer of cash
- Consistency with any other toll plazas in the area
- Environmental impact
- Land take and land suitability
- Capital cost
- Access to existing infrastructure

#### **2.3.3 Cost of Toll Collection**

The Operation Cost (OpEx) of new corridor cum road has been divided into several broad heads under Operational Expenditure in Table 2.3.3. It is evident from the table that the total annual operational cost will be Rs. 12.05 crore. The 'Toll Collection Expenses' covers the all required man power to collect the toll in three shifts in a day with 8 hours of working hours. The total number of tollbooths in new toll booth will be twenty-four, which is evenly distributed between up and down of traffic flow. Among the total toll booths, 18 booths will be active simultaneously to collect the toll.



Detail Project report for Construction of 11.85km long twin tube, 2 lanes + 1 emergency lane each highway tunnel for connecting Thane on Eastern Express Highway to Borivali on Western Express Highway in the state of Maharashtra

**Table 2.3.3: Annual OpEx of Toll Collection (Rs. Lakh)**

Expense Type	Unit Cost	No. Shifts	Total Cost in Lakh	Total Cost per toll booth	Total cost for 24 toll booths at a time (up+down)
<b>Toll collection expenses</b>	R lk./plaza				
1.Toll Collector	3 persons	3	40.0	55.0	990.0
2.Toll Attendant	3 persons	3			
3.Barrier man	3 persons	3			
4.Channelizer	3 persons	3			
5.Gun man	3 persons	3			
<b>Administrative Officer</b>	1 person	1	5.0		
<b>Plaza Manager</b>	1 person	1	6.0		
<b>Accountant</b>	1 person	1	4.0		
<b>Patrolling expenses &amp; Security Officers</b>	-	-	-	-	66.86
<b>Electricity expenses</b>	-	-	-	-	33.43
Electrician	-	-	-	-	
<b>Other office expenses</b>	R lk.				
1.Safaiwala	1 person	1	-	-	3.0
2.Peon	1 person	1	-	-	
<b>Total Annual Operational Expenditure in Lakh of Rupees</b>				-	<b>1093.29</b>
<b>Total Annual Operational Expenditure in crore of Rupees</b>				-	<b>10.93</b>

The total annual Operation and Maintenance Costs are Rs. 12.05 crore and Rs. 14.16 crore respectively, totaling Rs. 26.21 crore. The total number of toll plaza will be one with 24 booths on both side of the traffic flow among which 18 toll booths will be operated simultaneously. The total fixed O&M cost at nominal prices is shown below, which shows the O&M costs will increase over time and periodic maintenance cost will also increase at 5 years interval and will be adjusted with prevailing inflation rate.

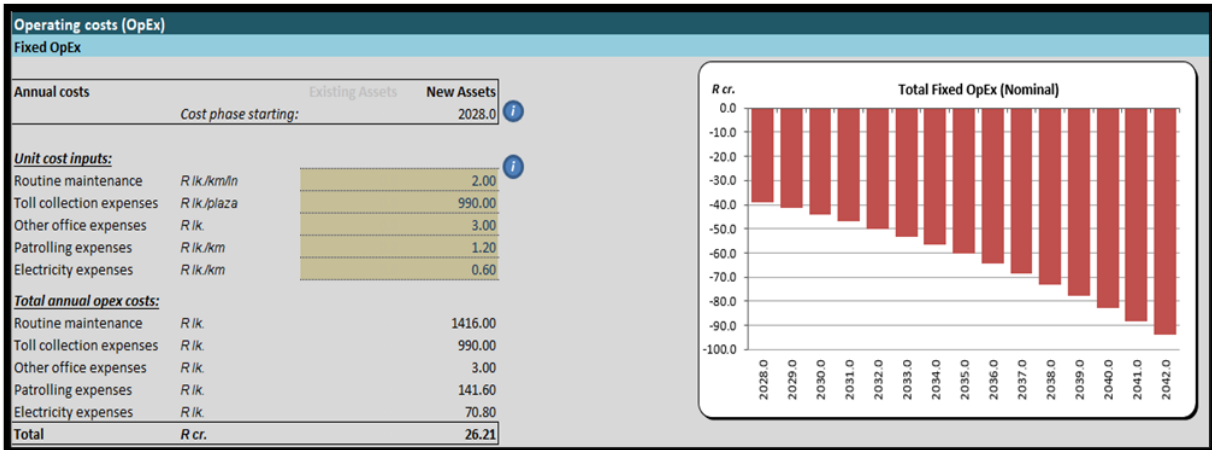



### 3.0 Toll-able Traffic

#### 3.1 Traffic

The following section of the report deals with the tollable traffic in the year 2023 for SGNP tunnel.

#### 3.2 Existing Traffic

Average Daily Traffic (ADT) and Annual Average Daily Traffic (AADT) of the project road are shown in Table-3.2

Traffic on Tunnel (AADT)						PCU
Years	Car	LCV	Trucks	Bus	Total	
2017	16781	2371	1821	1363	22336	28704
<b>Growth Rate</b>	<b>7.5%</b>	<b>9.0%</b>	<b>9.0%</b>	<b>7.0%</b>		
2018	18040	2584	1985	1458	24067	30954
2019	19393	2817	2164	1560	25934	33382
2020	20847	3071	2358	1670	27945	36001
2021	22411	3347	2570	1787	30114	38829
2022	24091	3648	2802	1912	32453	41880
<b>Growth Rate</b>	<b>6.8%</b>	<b>8.5%</b>	<b>8.5%</b>	<b>6.6%</b>		
2023	25730	3958	3040	2038	34766	44921
2024	27479	4295	3298	2172	37244	48186
2025	29348	4660	3579	2316	39902	51691
2026	31343	5056	3883	2469	42751	55454

#### 3.3 Objective of Tolling

The primary objectives of tolling of the new corridor are to generate sufficient revenues that will enable repayment of the loan and the operating costs of the project road (including future capital expenditures) while still helping to improve accessibility. Other objectives include:

- Improved operation and maintenance of the bridge and structure which will protect the Government's investment in the road asset.
- Diversify the source of funding for the development and maintenance of the road network.
- Revenuemaximizationalthoughthishastobebalancedbytheprimaryobjectiveof time saving.
- Ensuring the costs are proportionate to the benefits the user derives from the use of the road.

Tolling strategy for the road project must support wider transport objectives through affecting the relative price of different modes of transport. With tolling there are two components a) the provision of tolling infrastructure and b) Toll for Operation & Maintenance activities.

#### 3.4 Consequences of Tolling

The number of consequences from tolling, some of which will be deliberate, such as the generation of revenue, while others may not have been foreseen. Intentional and unintentional consequences of tolling are likely to be included:

1. Traffic and toll tariff levels may be insufficient on the project to cover all costs of operation and maintenance. Additional funding may be required from sources, such as government subsidy, public (e.g. from development banks) or private borrowing and may create long term liabilities for the governments.



2. Price elasticity of demand and the provision of toll-free alternatives to the tolled bridge, may affect the level of traffic on the bridge. High toll tariffs can result in diversion away from the road to less suitable routes, resulting in the loss of some of the potential economic benefits of the highway accruing from improvements in travel time reliability, time savings, vehicle operating costs and highway safety.
3. The tolling strategy should take into account the interests of key stakeholders. The key stakeholders are: MMRDA, Private Investor, Bank, Toll Operators, Users and Enforcement agencies.

### 3.5 Standards

Apart of the guidelines laid down at the toll policy framework level, standards and specifications need to be established. The standards and specifications document shall cover all aspects of toll including:

- a. Technical Standards for Civil works viz. toll lanes and islands, flare areas, administrative and other buildings.
- b. Safety Standards for occupational health and safety.
- c. Equipment specifications for toll management system hardware and software, reports, audit requirements, networking standards etc.
- d. Mechanical, Electrical and Plumbing (MEP) standards.
- e. Any other legally applicable standard for toll plaza activities related to environment, medical waste disposal, fuel storage and consumption etc.

### 3.6 Basic Structure of Financial Model

The toll rates of the project road for each category of vehicle have been determined on the basis of “National Highways Fee (Determination of Rates and Collection) Rules, 2008”. The following key points have been considered for Financial Analysis:

- Construction Start Year: 2023.
- Construction End Year: 2027.
- Construction Period: 5.0 Years.
- Open for traffic for Commercial Operation from 2028.
- Analysis Period: 20 years including Construction Period (2023-2042)
- PPP Concession Period including Construction Period: 20 Years.
- **Funding Structure:** Grant-0%, Debt-70% and Equity-30%, Loan Term-10 Years.
- Analysis Year: November, 2022.
- Inflation Rate is 6.5% per annum.
- Corporate Tax Rate is 28.99% for entire project life as per Corporate Tax Rule, 2018.
- Cost of Debt (Interest Rate during construction and operation) is 9.0% per annum.
- Weighted Average Capital Cost (Nominal) is 10.8%.
- Cost of Equity is 15.0% per annum.
- Capital Structuring: Equity from Private Investor (30%) and Debt from Bank (70%).
- Moratorium Period is 5.0 years.
- Effective Loan Repayment duration is 10 Years.
- Annual O&M Cost including Heavy Maintenance is Rs. 26.21 crore per year.

### 3.7 Determination of basic toll rate

Toll Rate has been determined according to “National Highways Fee (Determination of Rates and Collection) Rules, 2008”. Calculation of fee amount, to be charged from road users of SGNP, is as per actual road and equivalent road length of proposed structure portion (The Gazette of India, 16<sup>th</sup> January, 2014/ REGD. NO. D.L – 33004/99).

**Table 3.7.1: Determination of Base Toll Rate as per “National Highways Fee Rules, 2008”**

	User fee for SGNP	2022			
		Car	LCV/Mini Bus	Bus/ 2-Axle Truck	MAV (3 axle)
Revised Base Rate	Base Rate	0.65	1.05	2.2	2.4
	Fixed Increase (14*3%)	0.27	0.38	0.79	0.86
	Revised Base Rate	0.92	1.43	2.99	3.26
Variable Increase	WPI as on 06.01.2007	208.70	208.70	208.70	208.70
	WPI for Dec, 2021 (143.3x1.873x1.641=440.4459)	440.4	440.4	440.4	440.4
	40% of increase in WPI (as % of revised base rates)	0.44	0.44	0.44	0.44
	Increase in base rates due to change in WPI	0.41	0.63	1.33	1.45
	Revised base rates (after WPI adjustment)	1.33	2.06	4.32	4.71
Road Length (km)	Road length in km (excluding length of bypass if any)	11.800	11.800	11.800	11.800
	Structure on road length in km	11.80	11.80	11.80	11.80
	Net road length without structure	0.000	0.00	0.00	0.00
Bypass length (km)	Length of the bypass costing more than 10 crores	0	0	0	0
	Structure on bypass length in km	0	0	0	0
	Net length of bypass costing more than 10 cr without structures>60m	0	0	0	0
Structure Length (km)	Total Length of structure >60m	11.80	11.80	11.80	11.80
	Converted equivalent road length for structure in km>60m	118	118	118	118
Toll Rate Calculation	Total Tollable road length in km	<b>118.00</b>	<b>118.00</b>	<b>118.00</b>	<b>118.00</b>
	Fee for the road stretches	157.29	243.35	509.87	556.23
	Fee for the bypass	0.00	0.00	0.00	0.00
	Fee for the whole section	157.29	243.35	509.87	556.23
	<b>Rounded off fee for single trip</b>	<b>155</b>	<b>245</b>	<b>510</b>	<b>555</b>

	User fee for SGNP	2028			
		Car	LCV/Mini Bus	Bus/ 2-Axle Truck	MAV (3 axle)
Revised Base Rate	Base Rate	0.65	1.05	2.2	2.4
	Fixed Increase (20*3%)	0.39	0.63	1.32	1.44
	Revised Base Rate	1.04	1.68	3.52	3.84
Variable Increase	WPI as on 06.01.2007	208.70	208.70	208.70	208.70
	WPI for Dec, 2021 (143.3x1.873x1.641=440.4459)	440.4459	440.4459	440.4459	440.4459
	40% of increase in WPI (as % of revised base rates)	0.44	0.44	0.44	0.44
	Increase in base rates due to change in WPI	0.46	0.75	1.56	1.71
	Revised base rates (after WPI adjustment)	1.50	2.43	5.08	5.55
Road Length (km)	Road length in km (excluding length of bypass if any)	11.800	11.800	11.800	11.800
	Structure on road length in km	11.80	11.80	11.80	11.80
	Net road length without structure	0.000	0.00	0.00	0.00
Bypass length (km)	Length of the bypass costing more than 10 crores	0	0	0	0
	Structure on bypass length in km	0	0	0	0
	Net length of bypass costing more than 10 cr without structures>60m	0	0	0	0
Structure Length (km)	Total Length of structure >60m	11.80	11.80	11.80	11.80
	Converted equivalent road length for structure in km>60m	118	118	118	118
Toll Rate Calculation	Total tollable road length in km	<b>118.00</b>	<b>118.00</b>	<b>118.00</b>	<b>118.00</b>
	Fee for the road stretches	177.23	286.29	599.85	654.38
	Fee for the bypass	0.00	0.00	0.00	0.00



Detail Project report for Construction of 11.85km long twin tube, 2 lanes + 1 emergency lane each highway tunnel for connecting Thane on Eastern Express Highway to Borivali on Western Express Highway in the state of Maharashtra

Fee for the whole section	177.23	286.29	599.85	654.38
<b>Rounded off fee for single trip</b>	<b>175</b>	<b>285</b>	<b>600</b>	<b>655</b>

### 3.8 Exemptions from Toll Charges

The following categories of vehicles will be accorded exemption:

- Emergency vehicles will not be charged to use the road, in addition vehicles of Police Service, Defense Force, and other as per toll policy vehicles will also not to be charged.
- In order for military and emergency services vehicles to receive the exemption, an official warrant (or alternate acceptable documentation) must be produced in the toll lane as proof of the right to exemption.
- Discounts to be offered to frequent users to keep transport fees affordable

### 3.9 Indexing of Toll Rates

Indexing allows the operators to adjust toll rates to new price level. The toll indexation will be according to the “National Highways Fee (Determination of Rates and Collection) Rules, 2008”, by using Wholesale Price Index as published by Reserve Bank of India in each year. Toll rate adjustment will be done periodically that is in each year as prescribed by toll policy without compounding but interim adjustment may be necessary sometime with prior permission from MMRDA, if the requirement arises. Under periodic adjustments toll rates will be adjusted at each year of time interval. Interim adjustments will be undertaken in case of extraordinary circumstances. The toll rates for the years 2025, 2030 and 2035 will be effective from 1<sup>st</sup> April of each subsequent year as mentioned. The following Table 3.9.1 shows the proposed toll rate of categories of vehicle over the years in 2022 price level. The following formula will be used to determine the applicable base toll rate across all categories of vehicles on entire road stretch of new bypass:

$$\text{Applicable Toll Rate} = \text{Base Toll Rate} + \text{Base Toll Rate} * \left[ \frac{\text{WPI A} - \text{WPI B}}{\text{WPI B}} \right] * 0.4$$

**Table 3.9.1 Proposed Inflation Adjusted Toll rate (WPI, 2012=100, at 2022 Price Level)**

Vehicle Class	2022	2028
Car	155	175
LCV	245	285
Bus	510	600
Trucks	555	655

### 4.0 Discounts on User Fee

For daily users, a discount of 25% of fifty single rides will be given per month with maximum number of fifty single rides. It is also assumed that 1% of total road user will take an advantage of it.



## 5.0 Financial Modelling

The financial analysis seeks to evaluate the financial performance of the project and the viability of the proposed implementation plan with given structures. The financial analysis is structured with a proprietary of financial model.

### 5.1 Overview of Model

The financial model is designed to allow the testing of the financial implications of investment options at the feasibility level. It indicates the resources required to construct the road project to operate and maintain, to implement tolling infrastructure and to operate and maintain the required tolling infrastructure. The model generates financial cash flows, tests the ability of the project to serve its financial obligations, and indicates the key financial results of the selected scenario including Project NPV, Project IRR, and Debt Service Coverage etc.

### 5.2 Methodology for Analysis

The financial analysis centers on whether the cash flows from the project under a selected implementation scenario are sufficient to provide a reasonable level of return on the capital investment required to implement and maintain the project. What constitutes a reasonable level of return generally depends on who is making the investment, Government or the private sector. The goal of this analysis is ultimately to derive the project cash flows over the forecast period for the analysis of the investment return on selected implementation structure. The cash flows are calculated using a build-up approach. The analysis focuses on the annual cash flows arising from the project. The Internal Rate of Return (IRR) of project on net cash flow has been determined in order to understand the extent of financial return available to investors.

### 5.3 Key Dates and Contract Period

The project and related contract(s) are expected to start in 2023 as the construction period is planned to start from 2023. The model is capable of generating financial projections up to 20 years based on the capital investment. **Table 5.3** below summarizes the key dates and time lines relevant to the financial projections and the analysis:

**Table 5.3: Assumptions on Key Dates and Durations**

Assumptions	Dates/Duration
Corridor Name	SGNP
Corridor Length	11.8 km
New Corridor Civil Cost at 2022 price level	Rs. 12752 Cr
Construction Start Date	2023
Construction End Date	2027
Construction Period	5.0 Years
Open to Traffic	1 <sup>st</sup> January, 2028
Concession Period	20 years
Operating Days per Year	365/366 days

Source: Consultant



#### 5.4 Total Project Cost (TPC)

The details of the total project cost (TPC) have been extensively studied and analyzed in the Section 2.0 of this report and Table 2.1 is showing that the TPC of the new corridor is Rs. 12752 crore including the toll plaza construction cost.

#### 5.5 Stakeholders

The key stakeholders in this project are the private investor and the Bank.

#### 5.6 Critical Factors

The critical factors that will influence financial viability of this project are:

- Capital Cost
- Traffic Volume
- User fees
- Concession period

#### 5.7 Length of Project considered

The present report has considered the corridor length 11.8 km for financial analysis among which length of the structure is 11.8 and remaining 0.0 km is the at grade road section.

#### 5.8 Toll Efficiency

On and from the date of commercial operation, MMRDA will charge user fee on the basis of the Total Project Cost & Operation and Maintenance Cost under the BOT-Toll settings. The local traffic will not get access to the new corridor as the old one will be open for local transportation of pedestrian, cycle, rickshaw, auto and motorcycle as well. The monthly frequent users of the new bridge will be given discounted rate of 25% as per toll policy. Traffic attempted to evade fee will be charged twice. Additional fee may be charged for overloading. A tentative distribution of toll-able traffic among different categories of traffic is given in **Table 5.8**.

**Table 5.8: Toll Efficiency (%)**

Types of vehicles	Toll-able Traffic (%)
Car/Jeep	98
Bus/2-Axle Truck	100
LCV/Mini Bus	100
MAV (3-Axle)	100
MAV (4-6 Axle)	100

#### 5.9 Insurance & Financing Fee

The concessionaire has to offer each year insurance cover at their own cost. The cost of insurance is considered 0.0% of civil cost in 2022 price level and financing cost has been assumed to be 0% of the total debt portion.



### **5.10 Electricity and Patrolling**

The concessionaire has to offer electricity and patrolling at their own cost. The cost of patrolling and electricity are considered as Rs. 1.4 Cr and Rs. 0.7 Cr per year respectively. The annual costs of patrolling and electricity have been adjusted in main model of Financial Analysis (main software which has been used for the Financial Analysis).

### **5.11 Financial Parametric Considerations**

The financial viability analysis of the project has been formulated after taking into consideration the following key aspects:

- Concession period of maximum 20 years have been considered including construction period of 5 years.
- Project financial analysis has been carried out on half-yearly basis for 20 years.
- Moratorium period is 5 years.
- Loan Term is 15 years including 5 years of moratorium period.
- Effective loan term for repayment is  $(15-5) = 10$  years.

### **5.12 Estimation of Cut-off Equity IRR**

There is a 30% investment of equity of Total Project Cost and the Equity IRR has been set at 15.0% as cut-off equity rate of return for the private investor.

### **5.12 Key Assumptions**

The following assumption and the parametric values of the model have been considered for this financial analysis. The specifications have been configured in the model and whole analysis has been carried out on the basis of that.

### **5.13 Debt-Equity Ratio**

Based on the size of the project and prevalent market conditions for financing infrastructure projects in India, a Debt-Equity ratio of 70:30 has been assumed for this project under BOT-Toll setup, which is maximum possible scenario under the current settings.

### **5.14 Rate of Interest**

The interest rate has been considered at 9.0% per year and model estimated nominal Weighted Average Capital Cost (WACC) is 10.8%.

### **5.15 Tax**

The Corporate Tax Rate has been applied on this project and it is 28.99% for entire project life as per Corporate Tax Rule, 2018.

### **5.16 Inflation Rate**

The current inflation rate has been assumed at 6.5% per annum. The inflation rate will be adjusted accordingly with the prevailing inflation rate, announced by Ministry of Commerce and Industry, Govt. of India over the years of operation and toll rate indexation.

### **5.17 Toll Plaza**

One toll plaza with 18 toll booths has been considered for 6 lane provisions have been considered.



### 5.18 Loan Repayment

The toll will be collected by the private investor. Being the owner of the project, repayment of the loan to the bank over the year of 15 years among which first 5 years is the moratorium period (the construction period: 2023-2027). The loan repayment will start in the year 2028 and ends in the year 2037. Here, private investor will repay a fixed amount of fund, that is, Rs. 1036.5 Cr as loan repayment in each six months of interval will be paid to the bank (bi-annual payment).

### 5.19 Revenue Model

For developing the revenue model, results of the traffic-forecast exercise based on analysis of traffic on the project corridor have been used. Traffic volumes of entire section have been taken for the purpose of this analysis and 2028 would be the year when the facility is expected to start operation. The model takes the revenue streams into account from users' fees. The following Figure 5.19 indicates overall amount of revenue from the project under the current scenario of toll rate. However, the model asserts that the maximum revenue is generating from Car whereas it is minimum from bus.

Figure 5.19: Revenue from Road User Charges (Nominal)

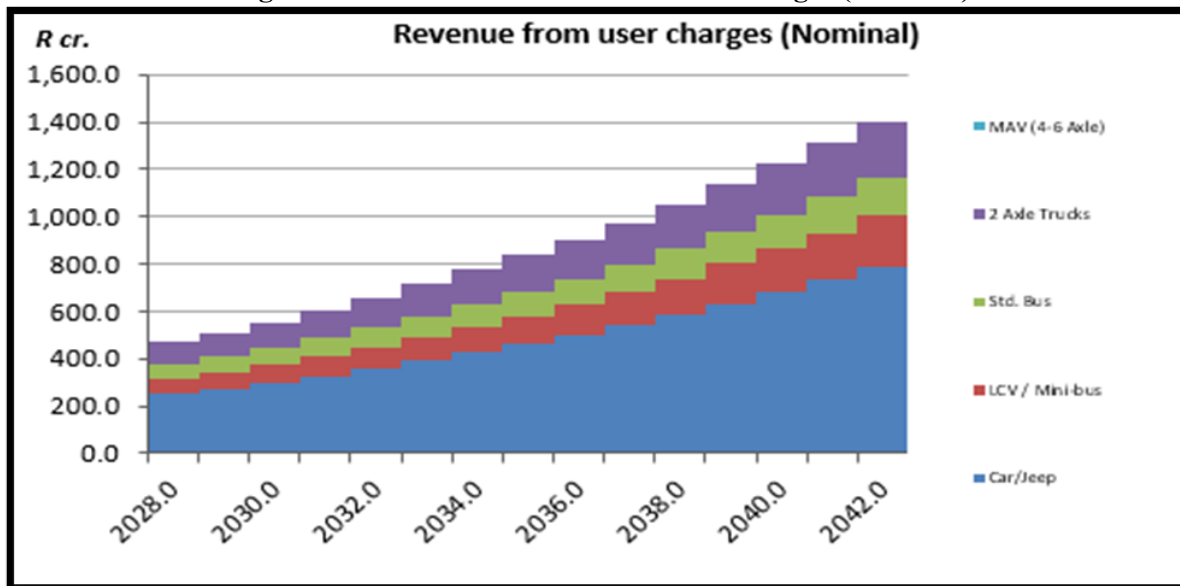

Source: Financial Model

### 5.20 Revenue from Other sources

The other sources of revenue are: road-side advertisement, charges from data cables along the road alignment, income from parking bay etc. The income from sources is considered as 0% of total toll revenue.



Detail Project report for Construction of 11.85km long twin tube, 2 lanes + 1 emergency lane each highway tunnel for connecting Thane on Eastern Express Highway to Borivali on Western Express Highway in the state of Maharashtra

## 5.21 Financial Evaluation Results

### 5.21.1 Project IRR

The following Table 5.21.1 are showing the project IRR is -3.1%. The project NPV was Rs. - 8398.7 crore discounting at the rate of 10.8% (WACC-Nominal) per year.

**Table 5.21.1: Project IRR and Project NPV**

Overall project cashflows and returns	
NPV of project cashflows (Cost of Capital = 10.8%):	-8,398.7 R cr.
<i>made up of (in present value terms)</i>	
Revenue:	3,204.1 R cr.
Operating costs:	-236.2 R cr.
Construction costs:	-11,229.9 R cr.
Tax:	-136.7 R cr.
VGf grant funding:	0.0 R cr.
Project IRR:	-3.1% <input type="button" value="Update"/>

Project results	
EBITDA	
Actual tax paid	
Construction costs	
Grant dispersals	
Operating CF including grants	
Project IRR	-3.1%
Project NPV @ 10.8% discount p.a.	-8,398.67

### 5.21.2 Equity IRR

The Equity IRR shows the rate of return for the private partner, that is, private investor. The figure 5.21.1 (both figures) are showing that the Equity IRR for this project is 0.0% with NPV of Rs. - 2998.6 Cr discounting at the rate of 15.0% per year. The project found financially unviable under the current settings from private investors perspective.



Detail Project report for Construction of 11.85km long twin tube, 2 lanes + 1 emergency lane each highway tunnel for connecting Thane on Eastern Express Highway to Borivali on Western Express Highway in the state of Maharashtra

Figure 5.21.1: Equity IRR and NPV

	Nominal	Real
<b>Equity IRR required by private sector partners:</b>	15.0%	8.0%
<b>Terminal (real) payment to private sector partner:</b>	R cr.	0.0
<b>Private investor perspective: Shareholder cashflows and returns</b>		
NPV of shareholder cashflows (Cost of Equity = 15.0%):	-2,998.6	R cr.
<i>made up of</i>		
Equity invested (present value):	-2,998.6	R cr.
Dividends received (present value):	0.0	R cr.
Equity IRR of the project:	0.0%	Update
<b>This project is not viable from a private sector perspective. If possible, changes should be made to the funding, revenue or cost structure.</b>		

<b>Shareholder results</b>	
Construction equity	
Dividends and equity redemption	
Shareholder cash flow	
Equity IRR	0.0%
Equity NPV @ 15.0% discount p.a.	-2,998.62

### 5.22 Debt Service & Loan Life Coverage Ratio (DSCR & LLCR)

The following Figure 5.22.1 (both figures) are showing the average Debt Service Coverage Ratio (DSCR) and Loan Life Coverage Ratio (LLCR) for this project is 0.31 and 0.52 respectively, which indicates the project does not have strong loan repayment capacity. The Figure 5.22.1 of Project Ratios indicates that Net Profit Margin is always above Loan Life Coverage curve except construction period.



Detail Project report for Construction of 11.85km long twin tube, 2 lanes + 1 emergency lane each highway tunnel for connecting Thane on Eastern Express Highway to Borivali on Western Express Highway in the state of Maharashtra

**Figure 5.22.1: Project Ratios**

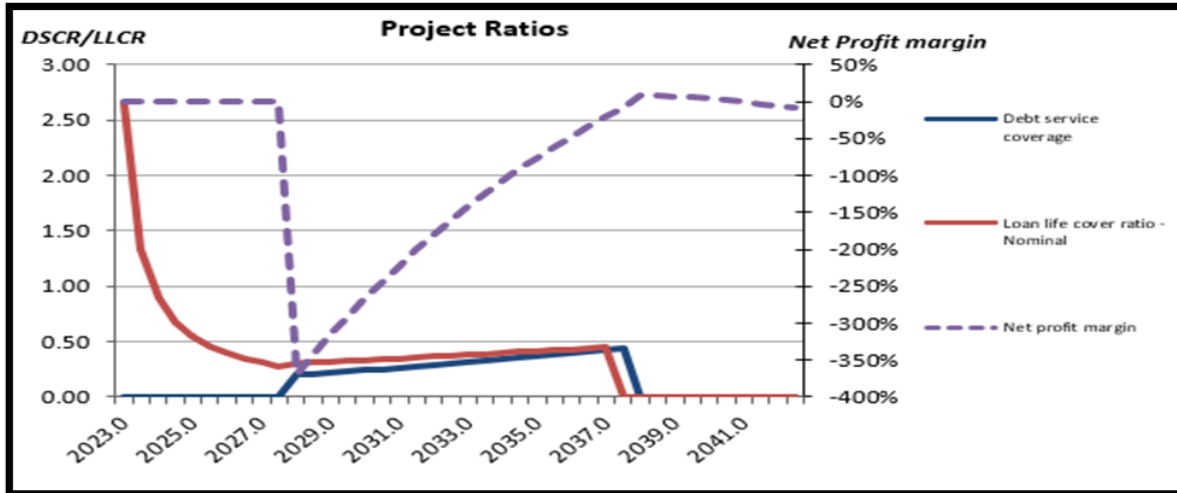

Debt service coverage	
Cash available for debt service	
Total debt service	
Debt service coverage	
Minimum	0.20
Average	0.31
Loan life cover ratio - Nominal	
Cash available for debt service during loan term	
Present value of cash available	
Outstanding debt	
Loan life cover ratio	
Minimum	0.28
Average	0.52

### 5.23 Summary of Financial Results

The following Table 5.23.A is showing the summary of the Financial Analysis under the current setting of analysis under this scenario, the proposed toll rates have been used to obtain corresponding Project IRR:

**Table 5.23.A: Summary of Financial Evaluation**

Years	Proposed Toll Rate				Financial Indicators							
	Car	LCV/ Mini Bus	Bus/2 Axle Truck	MAV (3 Axle)	Project IRR*	Equity IRR*	Nominal WACC	Average DSCR	Average LLCR	NPV of shareholders cashflow (discounting at 15.0%)	NPV of project cashflow (discounting at WACC @ 10.8%)	
2022	155	245	510	555	-3.1%	0.0%	10.8%	0.31	0.52	-2998.6	-8398.7	
2028	175	285	600	655								

\*Cut-off Project IRR is 15.0% (Nominal WACC) and Equity IRR is 10.8%.



Detail Project report for Construction of 11.85km long twin tube, 2 lanes + 1 emergency lane each highway tunnel for connecting Thane on Eastern Express Highway to Borivali on Western Express Highway in the state of Maharashtra

The cash flow Figure 5.23.B as shown below indicates that income from user charges has steady rising trend except initial 5 years. The O&M costs increase over time and tax payment also increases along with revenue increase. The following Table 5.23.B is showing the Total Cash flow (Nominal) of the project in figures in every twelve months of interval.

**Figure 5.23.B: Total Cash Flow**

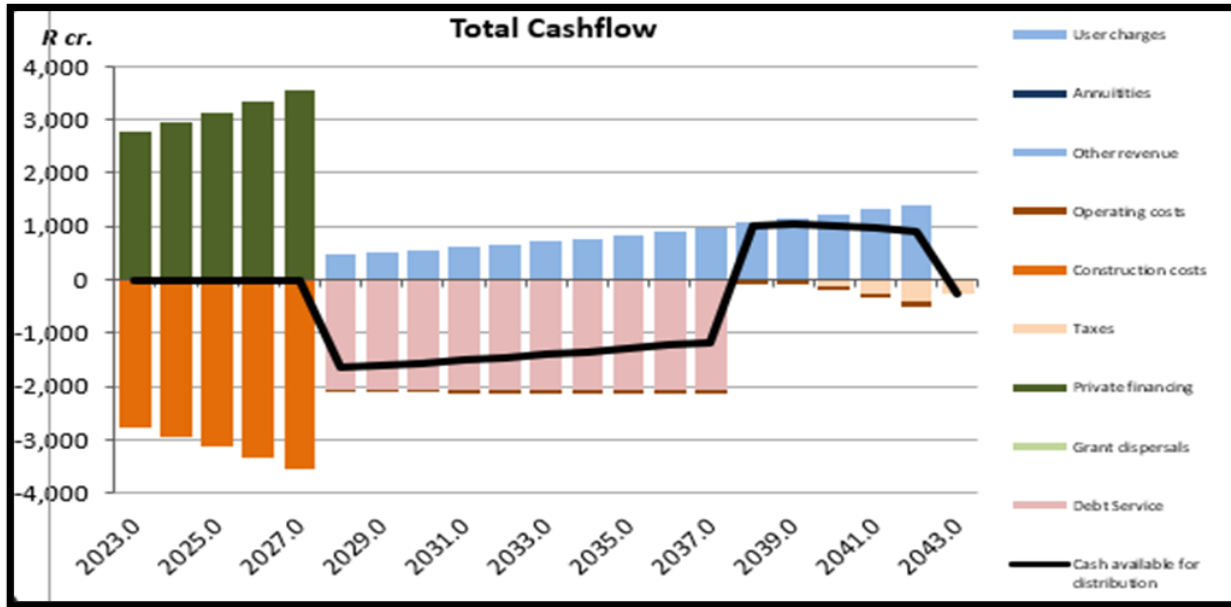

### 5.23.2 Cash Flow

The table 5.23.2.A shows the total project cashflow under the BOT-Toll setup. The entire analysis has been done on the basis of the aforesaid setup and the entire cashflow has been analyzed accordingly.

**Table 5.23.2.A: Cash Flow (Nominal) of the project (Rs. Crore)**

Years	Revenue	Operating costs	Construction costs	Taxes	Cash flow before financing	Equity	Debt	Cash flow available for debt service	Debt Service		Cash available for distribution
									Interest	Principal	
2023	0.0	0.0	-1358.0	0.0	-1358.0	407.4	950.6	0.0	0.0	0.0	0.0
2023.5	0.0	0.0	-1401.4	0.0	-1401.4	420.4	981.0	0.0	0.0	0.0	0.0
2024	0.0	0.0	-1446.3	0.0	-1446.3	433.9	1012.4	0.0	0.0	0.0	0.0
2024.5	0.0	0.0	-1492.5	0.0	-1492.5	447.8	1044.8	0.0	0.0	0.0	0.0
2025	0.0	0.0	-1540.3	0.0	-1540.3	462.1	1078.2	0.0	0.0	0.0	0.0
2025.5	0.0	0.0	-1589.5	0.0	-1589.5	476.9	1112.7	0.0	0.0	0.0	0.0
2026	0.0	0.0	-1640.4	0.0	-1640.4	492.1	1148.3	0.0	0.0	0.0	0.0
2026.5	0.0	0.0	-1692.8	0.0	-1692.8	507.9	1185.0	0.0	0.0	0.0	0.0
2027	0.0	0.0	-1747.0	0.0	-1747.0	524.1	1222.9	0.0	0.0	0.0	0.0
2027.5	0.0	0.0	-1802.9	0.0	-1802.9	540.9	1262.0	0.0	0.0	0.0	0.0
2028	229.4	-19.1	0.0	0.0	210.3	0.0	0.0	210.3	-598.7	-437.8	-826.2
2028.5	239.3	-19.7	0.0	0.0	219.5	0.0	0.0	219.5	-579.4	-457.1	-817.0
2029	249.6	-20.4	0.0	0.0	229.2	0.0	0.0	229.2	-559.3	-477.2	-807.3
2029.5	260.3	-21.0	0.0	0.0	239.3	0.0	0.0	239.3	-538.3	-498.3	-797.2
2030	271.5	-21.7	0.0	0.0	249.8	0.0	0.0	249.8	-516.3	-520.2	-786.7
2030.5	283.2	-22.4	0.0	0.0	260.9	0.0	0.0	260.9	-493.4	-543.1	-775.7
2031	295.5	-23.1	0.0	0.0	272.4	0.0	0.0	272.4	-469.5	-567.0	-764.2
2031.5	308.2	-23.8	0.0	0.0	284.4	0.0	0.0	284.4	-444.5	-592.0	-752.1
2032	321.5	-24.6	0.0	0.0	296.9	0.0	0.0	296.9	-418.5	-618.0	-739.6
2032.5	335.4	-25.4	0.0	0.0	310.0	0.0	0.0	310.0	-391.3	-645.2	-726.5
2033	349.9	-26.2	0.0	0.0	323.7	0.0	0.0	323.7	-362.8	-673.7	-712.8



2033.5	365.0	-27.0	0.0	0.0	337.9	0.0	0.0	337.9	-333.2	-703.3	-698.6
2034	380.8	-27.9	0.0	0.0	352.9	0.0	0.0	352.9	-302.2	-734.3	-683.7
2034.5	395.5	-28.8	0.0	0.0	366.7	0.0	0.0	366.7	-269.9	-766.6	-669.8
2035	410.8	-29.7	0.0	0.0	381.1	0.0	0.0	381.1	-236.1	-800.4	-655.4
2035.5	426.7	-30.7	0.0	0.0	396.0	0.0	0.0	396.0	-200.9	-835.6	-640.5
2036	443.2	-31.7	0.0	0.0	411.6	0.0	0.0	411.6	-164.1	-872.4	-624.9
2036.5	460.4	-32.7	0.0	0.0	427.8	0.0	0.0	427.8	-125.7	-910.8	-608.8
2037	478.3	-33.7	0.0	0.0	444.6	0.0	0.0	444.6	-85.6	-950.9	-592.0
2037.5	496.8	-34.8	0.0	0.0	462.0	0.0	0.0	462.0	-43.7	-992.8	-574.5
2038	516.1	-35.9	0.0	0.0	480.2	0.0	0.0	480.2	0.0	0.0	480.2
2038.5	536.1	-37.0	0.0	24.1	523.1	0.0	0.0	523.1	0.0	0.0	523.1
2039	556.9	-38.2	0.0	3.1	521.8	0.0	0.0	521.8	0.0	0.0	521.8
2039.5	578.5	-39.5	0.0	-21.1	518.0	0.0	0.0	518.0	0.0	0.0	518.0
2040	601.0	-40.7	0.0	-48.5	511.8	0.0	0.0	511.8	0.0	0.0	511.8
2040.5	622.1	-42.0	0.0	-78.7	501.4	0.0	0.0	501.4	0.0	0.0	501.4
2041	644.0	-43.4	0.0	-111.8	488.9	0.0	0.0	488.9	0.0	0.0	488.9
2041.5	666.7	-44.8	0.0	-147.5	474.4	0.0	0.0	474.4	0.0	0.0	474.4
2042	690.2	-46.2	0.0	-185.8	458.2	0.0	0.0	458.2	0.0	0.0	458.2
2042.5	714.5	-47.7	0.0	-226.4	440.5	0.0	0.0	440.5	0.0	0.0	440.5

### 5.24 Sensitivity Analysis

A sensitivity analysis is a technique used to determine how different values of an independent variable impact a particular dependent variable under a given set of assumptions. In BOT infrastructure project financial risks always associated with the project. Major critical risks that are debt repayment risk, inflation risk and revenue risk. All these parameters depend on government policies and instruments that come into force time to time.

In present project, the sensitivity analysis has not been carried out as the project is financially not viable in base case scenario.

### 6.0 Analysis of Risk

Risk areas and respective sensitivity including its relevance during the project period have been identified and indicated below.

**Table 6.0: Risk Profile**

Type of Risk	Risk	Cost Driver	Allocation	Treatment/Remarks
Design Risk	Time overrun due to delays in approval of detailed design	Construction Costs	MMRDA	Design of the bridge is completed and Construction of the road completed
	Time overrun due to delays in approval of working drawings	Construction Cost	MMRDA	
Site Risk	Land acquisition for the Project	Construction Cost	MMRDA	Agreement between MMRDA & Private Party.
	Site Security	Construction Cost	MMRDA & Private Party	
	Environmental	Construction Cost	Private Party	
Construction Risk	Quality assurance and quality control	Construction Cost	Private Party	-
	Achieving Construction Standards and Specifications	Construction Cost	Private Party	
	Fit for purpose manuals, approvals and statutory certificates	Construction Cost	Private Party	
	Cost overrun and delay not caused by a relief or compensation event	Construction cost	Private Party	
	Shifting of utilities	Construction Cost	Private Party	
	Delays caused by Private Party	Construction Cost	Private Party	



Detail Project report for Construction of 11.85km long twin tube, 2 lanes + 1 emergency lane each highway tunnel for connecting Thane on Eastern Express Highway to Borivali on Western Express Highway in the state of Maharashtra

Type of Risk	Risk	Cost Driver	Allocation	Treatment/Remarks
	Delays due to Client's changes	Construction and possibly O&M cost	MMRDA	
	Labour disputes	Construction Cost	Private Party	
	Project management /integration / delay	Construction Cost	Private Party	
	Time and costs to satisfy commissioning	Construction Cost	Private Party	
	Damage/injury to third parties	Construction Cost	Private Party	
	Adequacy of insurance	Construction Cost	Private Party	
	Sub-contractor insolvency	Construction Cost	Private Party	
Post-construction risk	Latent defects	Life Cycle Cost	Private Party	
	Workplace Health and Safety	Life Cycle Cost	Private Party	

### 6.1 Cost Escalation Risks

The following table 6.1.A shows the items, responsible for cost escalation with cost drivers for this particular project under BOT-Toll settings:

**Table 6.1.A: Cost Escalation Risks**

Type of Risk	Risk	Cost Driver	Treatment/Remarks	
Force Majeure Risk	Weather	Life Cycle Cost and/or Performance Payment/Toll	In case of Force Majeure event the affected party will be compensated and impacts to be mitigated as per provision of concession agreement.	
	Force Majeure during operations	O&M Cost and possibly Performance Payment/Toll		
	Uninsurable risks (throughout the period)	Life Cycle Cost and/or Performance Payment/Toll		
	Political Force Majeure	O&M Cost and possibly Performance Payment/Toll		
Revenue Risk	Non-availability of road	Government Budget		
	Volume risk	O&M Cost and possibly Performance Payment/Toll		-
	Underperformance caused by tolling system	O&M Cost and possibly Performance Payment/Toll		-
O&M Risk	Increased maintenance due to traffic volume	O&M Cost and possibly Performance Payment/Toll	-	
	Incorrect estimates and cost overruns	O&M Cost and possibly Performance Payment/Toll	-	
	Actual operating and maintenance costs higher than anticipated	O&M Cost and possibly Performance Payment/Toll	-	
	Equipment used becomes prematurely obsolescent	Life Cycle Cost	-	
Performance Risk	Labour and material availability	Life Cycle Costs		
	Interface with sub-contractors	Life Cycle Costs		
	Change in scope of service specifications by MMRDA	Life Cycle Costs		



Detail Project report for Construction of 11.85km long twin tube, 2 lanes + 1 emergency lane each highway tunnel for connecting Thane on Eastern Express Highway to Borivali on Western Express Highway in the state of Maharashtra

Type of Risk	Risk	Cost Driver	Treatment/Remarks
	Expansion for traffic accommodation at ramps and interchanges due to traffic growth, or signalization	Life Cycle Costs	Responsibility of Private Party
	Future interchanges or additional lanes	Life Cycle Cost	
	Damage caused by unauthorized tyres e.g. spikes	Life Cycle Costs	
	Damage/injury to third parties	Life Cycle Costs	
	Damage to works, however caused, except as excluded	Life Cycle Costs	
	Water/air/soil pollution	Life Cycle Cost and/ or Performance Payment/Toll	
	Third party claims and accidents	Life Cycle Cost and/ or Performance Payment/Toll	
	Overloaded Vehicles	Life Cycle Cost and/or Performance Payment/Toll	
	Legal loading limits increased	Life Cycle Cost and/or Performance Payment/Toll	
	Traffic accidents	Life Cycle Cost and/or Performance Payment/Toll	
	Off road incidents	O&M Cost	
	Workplace Health and Safety	O&M Cost	
	Labour disputes	O&M Cost	
	Vandalism	Performance	
	Development Around Project Site Requiring Further Over Bridges or Under Passes or other Demographic Changes	Payment/Toll	
	Traffic Management	Life Cycle Cost	
Changes in standards			
Market Risk	Base interest rates to Financial Close	O&M Cost and possibly Performance Payment/Toll	
	Interest spread risk to Financial close	Life Cycle Costs	
	Currency fluctuations	Life Cycle Costs	
	Inflation on Construction Costs	Life Cycle Cost	
	Inflation on Operation, Maintenance, Rehabilitation	Life Cycle Cost	
	Costs of finance on change of requirements	Life Cycle Cost	
Other Market Risk	Change in law	Life Cycle Cost	
	General	Life Cycle Costs	
	Change in Toll operator	Life Cycle Costs	
	Change in taxation	Life Cycle Costs	



## 6.2 Sensitivity of Risks

The following table 6.2.A shows the sensitivity of risks associated with the project and the its duration to impact the project duration, mainly during construction.

**Table 6.2.A: Sensitivity of Risks**

Sl. No	Risk Area	Sensitivity	Relevance
1	Delays in land acquisition	High	0-5 Years
2	External Linkages	Low	0-5 Years
3	Financing Risk	Medium	0-5 Years
4	Planning	Medium	0-5 Years
5	Approvals	High	0-5 Years
6	Design Risk	Medium	0-5 Years
7	Construction Risk	Medium	0-5 Years
8	Technology Risk	Low	Throughout
9	O&M Risk	Medium	Throughout
10	Traffic Risk	High	Throughout
11	Payment Risk	High	Throughout
12	Financial Risk	Medium	Throughout
13	Change in Law	Low	Throughout
14	Force Majeure	Low	Throughout
15	Sponsor Risk	Medium	Throughout
16	Government event risk	Low	Throughout
17	Guarantor Risk if Government	Low	Throughout

## 7.0 Conclusion

It is observed that, the project is found financially unviable under current possible scenario of BOT-Toll mode. It is recommended to fund the project under HAM or EPC as the project has high EIRR.



## Hybrid Annuity Model (HAM)

### 1.1.0 Introduction and Background of the Project

AECOM carried out financial analysis after finalization of detailed engineering and cost estimation of the aforesaid project. Series of discussions were held with MMRDA officials while exploring possible alternative options to be considered during finalization of input parameters for financial analysis. It was informed by MMRDA, that project shall be implemented through HAM or EPC. Findings of the detailed financial analysis for selected option are summarized below.

### 1.2.0 Financial Analysis for selected option

#### 1.2.1 Total Project Cost (TPC)

The total project cost SGNP including Contingencies, interest during construction and financing cost on debt is Rs 13954.2 crore vide Table 1.2.1. The construction is assumed to commence in 2023 and will be completed by the end of 2027. The new corridor including the stretch will be opened for traffic in 2028. The land acquisition cost & rehabilitation cost costs are included from total project cost since that will be borne by the Government. The broad components of construction cost are as follows:

**Table 1.2.1: Construction Cost of the corridor (Rs. Cr.)**

<u>Sources</u>		<u>Uses</u>	
Equity (including finance costs)	2,295.4	0.0	Costs - design & development
Grant dispersal	5,100.8	12,752.0	Costs - civil construction
Debt	5,355.8	0.0	Costs - other
Compounded interest during construction	1,202.2	0.0	Contingency
		0.0	Insurance
		0.0	Financing costs
		1,202.2	Interest during construction
<b>Total</b>	<b>13,954.2</b>	<b>13,954.2</b>	<b>Total</b>

Source: Financial Model

The phasing of construction has been considered as 10% in every six months of period. The entire instalment profiles have been given in Table 1.2.2.1A.



Detail Project report for Construction of 11.85km long twin tube, 2 lanes + 1 emergency lane each highway tunnel for connecting Thane on Eastern Express Highway to Borivali on Western Express Highway in the state of Maharashtra

**Table 1.2.2.1A: Phasing Profile of Construction**

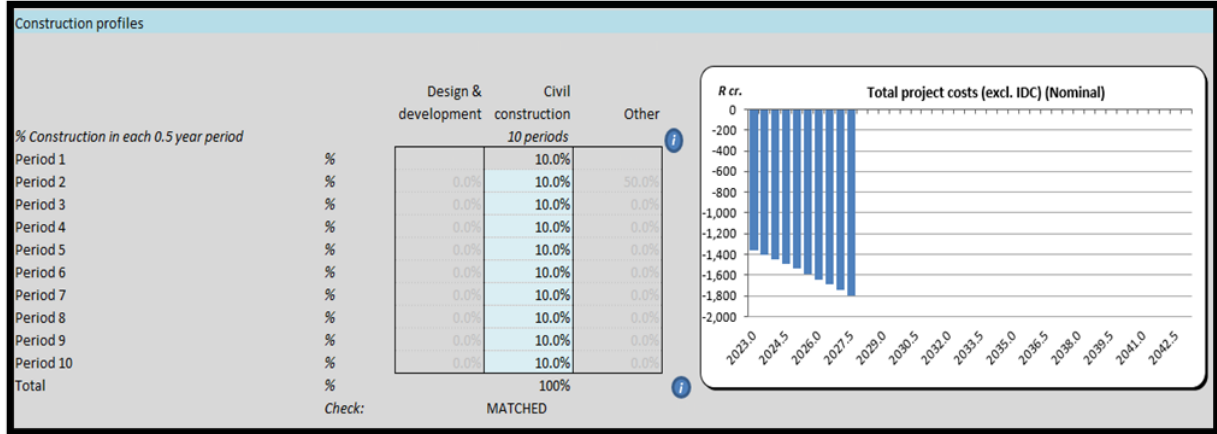

Source: Financial Model

### 1.2.2 Maintenance Cost

The annual maintenance cost of entire corridor including structure has been considered at Rs. 14.16 Cr. as per 2022 price level. These costs mainly cover the health monitoring cost, dewatering, painting and minor surface maintenance and expected cost of major maintenance as well if required, is given Figure 1.2.2.1:

- Routine maintenance including cost of major maintenance is Rs. 2.0 Lakh per km per lane.
- Total cost for maintenance is Rs. 14.16 Cr.
- Patrolling Expense is Rs. 1.0 Lakh per km per lane.
- Electricity Expense is Rs. 6.0 Lakh per km per lane
- Total Annual Expenditure (Fixed Cost) is Rs. 22.45 Cr.



Detail Project report for Construction of 11.85km long twin tube, 2 lanes + 1 emergency lane each highway tunnel for connecting Thane on Eastern Express Highway to Borivali on Western Express Highway in the state of Maharashtra

**Figure 1.2.2.1: Cost of Routine Maintenance**

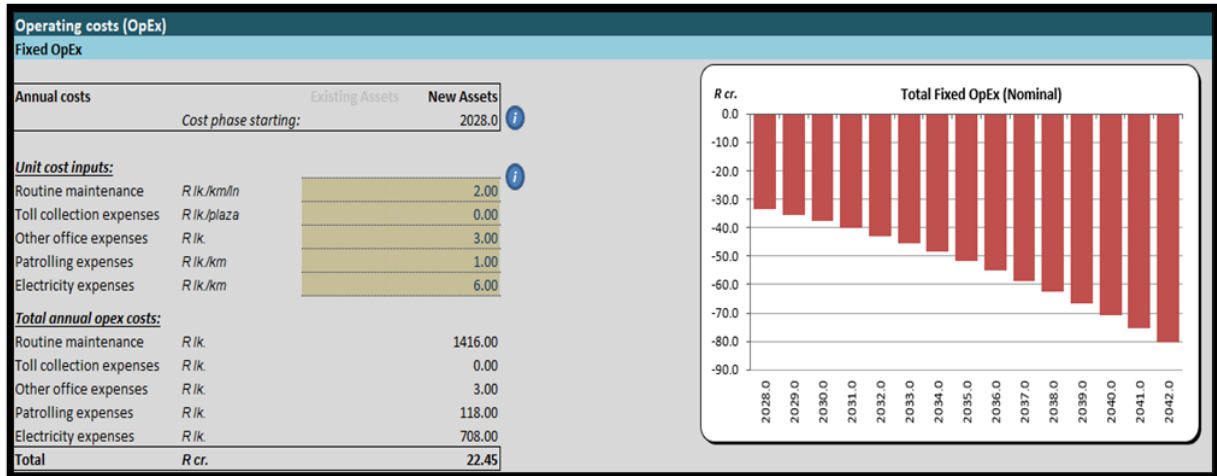

### 1.3.1 Recovery of Cost

The Financial Analysis has been done under the set-up of Hybrid Annuity Model (HAM) where toll will be collected by the authority, separately.

### 1.3.2 Basic Structure of Financial Model

The following key points have been considered for Financial Analysis:

- Construction Start Year: 2023.
- Construction End Year: 2027.
- Construction Period: 5 years.
- Open for traffic for Commercial Operation from 2028.
- Analysis Period: 20 years including Construction Period (2023-2027)
- Concession Period including Construction Period: 20 Years.
- **Funding Structure:** Grant-40%, Debt-42% and Equity-18%, Loan Term-10 Years.
- Analysis Year: November, 2022.
- Effective Debt: Equity Ratio is 70:30.
- Inflation Rate is 6.5% per annum.
- Corporate Tax Rate is 30% for entire project life as per Corporate Tax Rule.
- Cost of Debt (Interest Rate during construction and operation) is 9.0% per annum.
- Weighted Average Capital Cost (Nominal) is 9.9%.
- The benchmark Cost of Equity is 12% per annum (Interest rate plus 300 bps).
- Capital Structuring: Equity from Private Investor (30%) and Debt from Bank (70%).
- Moratorium Period is 5.0 years.
- Nominal Annuity Escalation Per annum is 6.5% (matched with WPI rate).
- Effective Loan Repayment duration is 10 Years.
- Annual O&M Cost is Rs. 22.45 crore per year including major maintenance.



### 1.3.3 Determination of basic toll rate

Toll will not be collected.

### 1.4.0 Discounts on User Fee

Not Applicable.

### 1.5.0 Financial Modeling

The financial analysis seeks to evaluate the financial performance of the project and the viability of the proposed implementation plan with given structures. The financial analysis is structured with a proprietary of financial model.

#### 1.5.1 Overview of Model

The financial model is designed to allow the testing of the financial implications of investment options at the feasibility level. It indicates the resources required to construct the road project to operate and maintain, to implement tolling infrastructure and to operate and maintain the required tolling infrastructure. The model generates financial cash flows, tests the ability of the project to serve its financial obligations, and indicates the key financial results of the selected scenario including Project NPV, Project IRR, and Debt Service Coverage etc.

#### 1.5.2 Methodology for Analysis

The financial analysis centers on whether the cash flows from the project under a selected implementation scenario are sufficient to provide a reasonable level of return on the capital investment required to implement and maintain the project. What constitutes a reasonable level of return generally depends on who is making the investment; Government or the private sector. The goal of this analysis is ultimately to derive the project cash flows over the forecast period for the analysis of the investment return on selected implementation structure. The cash flows are calculated using a build-up approach. The analysis focuses on the annual cash flows arising from the project. The Internal Rate of Return (IRR) of project on net cash flow has been determined in order to understand the extent of financial return available to investors.

#### 1.5.3 Key Dates and Contract Period

The project and related contract(s) are expected to start in 2023 as the construction period is planned to start from 2023. The model is capable of generating financial projections up to 20 years based on the capital investment. **Table 1.5.3** below summarizes the key dates and time lines relevant to the financial projections and the analysis:

**Table 1.5.3: Assumptions on Key Dates and Durations**

Assumptions	Dates/Duration
Corridor Name	SGNP
Corridor Length	11.8 km
New Corridor Civil Cost at 2021 price level	Rs. 12752 Cr.
Construction Start Date	2023
Construction End Date	2027
Construction Period	5.0 Years
Open to Traffic	1 <sup>st</sup> January, 2028
Concession Period	20 years (5+15)
Operating Days per Year	365 days

Source: Consultant



#### **1.5.4 Total Project Cost (TPC)**

The details of the total project cost (TPC) have been extensively studied and analyzed in the Section 1.2.0 of this report and Table 1.2.1 is showing that the TPC of the new corridor is Rs. 12752 crore excluding the toll plaza construction cost.

#### **1.5.5 Stakeholders**

The key stakeholders in this project are Government, private investor and the bank.

#### **1.5.6 Critical Factors**

The critical factors that will influence financial viability of this project are:

- Capital Cost
- Concession period
- Annuity payment.

#### **1.5.7 Length of Project considered**

The present report has considered the corridor length 11.8 km for financial analysis.

#### **1.5.8 Toll Efficiency**

Toll will be implemented by the authority, separately.

#### **1.5.9 Financing Fee**

The financing cost has been assumed to be 0.0% of the total debt portion during the financial analysis.

#### **1.5.10 Electricity and Patrolling**

As described and estimated in O&M cost.

#### **1.5.11 Financial Parametric Considerations**

The financial viability analysis of the project has been formulated after taking into consideration the following key aspects:

- Concession period of maximum 20 years have been considered including construction period of 5 years.
- Project financial analysis has been carried out on half-yearly basis for 20 years.
- Moratorium period is 5 years.
- Loan Term is 15 years including 5 years of moratorium period.
- Effective loan term for repayment is 10 years.

#### **1.5.12 Estimation of Cut-off Equity IRR**

There is a 18% investment of equity of Total Project Cost (which is 30% of total debt proportion) and the Equity IRR has been set at 12% as target equity rate of return for the private investor (Cost of Debt is 9% plus 3% slab as per rule, Govt. of India).

#### **1.5.12 Key Assumptions**

The following assumption and the parametric values of the model have been considered for this financial analysis. The specifications have been configured in the model and whole analysis has been carried out on the basis of that.



### 1.5.13 Debt-Equity Ratio

Based on the size of the project and prevalent market conditions for financing infrastructure projects in India, a Debt-Equity ratio of 70:30 has been assumed for this project under HAM setup, which is maximum possible scenario under the current settings.

### 1.5.14 Rate of Interest

The interest rate has been considered at 9.0% per year. The rate is same for during construction as well as operations. The cost of debt has been considered at 9.0%. The model estimated nominal Weighted Average Capital Cost (WACC) is 9.9%, which is the cut-off value for Project IRR.

### 1.5.15 Tax

The Corporate Tax Rate has been applied on this project and it is 30% for entire project life as per Corporate Tax Rule, 2018.

### 1.5.16 Inflation Rate

The current inflation rate has been assumed at 6.5% per annum.

### 1.5.17 Toll Plaza Cost

Toll Plaza construction cost has not been incorporated in the civil cost.

### 1.5.18 Loan Repayment

The authority will not apply any road user fee on the new road. The maintenance will be taken care by the private investor during the agreement period. The 40% of the total project cost will be a grant from the Govt. of India and will be paid during construction in 5 equal installments of 8% of each. Remaining 60% of the cost will be paid by the project authority over 15 years on bi-annual basis that is in every six months to the private investor. The repayment of the loan to the bank over the year of 15 years among which first 5 years is the moratorium period (the construction period: 2023-2027). The loan repayment will start in the year 2028 and ends in the year 2037. Here, private investor will repay a fixed amount of fund, that is, Rs. 622.0 Cr as loan repayment in each six months of interval will be paid to the bank (bi-annual payment), whereas the private party will be paid Rs. 858.5 Cr. as bi-annual payment from road authority.

### 1.5.19 Revenue Model

Here revenue refers to the bi-annual payment from MMRDA to the private investors over the period of analysis has been shown in Table 1.5.19:

**Table 1.5.19: Bi-Annual Annuity Payment Schedule**

Years	Annuity Payment (Rs. Cr.)	Bi-Annual Payments (Real Value)	Inflation adjusted bi-annual payment	Number of Annuity
2023	0	0%	0%	-
2023.5	0	0%	0%	-
2024	0	0%	0%	-
2024.5	0	0%	0%	-
2025	0	0%	0%	-
2025.5	0	0%	0%	-
2026	0	0%	0%	-
2026.5	0	0%	0%	-
2027	0	0%	0%	-



Detail Project report for Construction of 11.85km long twin tube, 2 lanes + 1 emergency lane each highway tunnel for connecting Thane on Eastern Express Highway to Borivali on Western Express Highway in the state of Maharashtra

2027.5	0	0%	0%	-
2028	626.3	2%	2.04%	1 <sup>st</sup> Annuity
2028.5	646.4	2%	2.10%	2 <sup>nd</sup> Annuity
2029	667.0	2%	2.17%	3 <sup>rd</sup> Annuity
2029.5	688.4	2%	2.24%	4 <sup>th</sup> Annuity
2030	710.4	2%	2.31%	5 <sup>th</sup> Annuity
2030.5	733.1	2%	2.38%	6 <sup>th</sup> Annuity
2031	756.6	2%	2.46%	7 <sup>th</sup> Annuity
2031.5	780.8	2%	2.54%	8 <sup>th</sup> Annuity
2032	805.8	2%	2.62%	9 <sup>th</sup> Annuity
2032.5	831.5	2%	2.70%	10 <sup>th</sup> Annuity
2033	858.1	2%	2.79%	11 <sup>th</sup> Annuity
2033.5	885.6	2%	2.88%	12 <sup>th</sup> Annuity
2034	913.9	2%	2.97%	13 <sup>th</sup> Annuity
2034.5	943.1	2%	3.06%	14 <sup>th</sup> Annuity
2035	973.3	2%	3.16%	15 <sup>th</sup> Annuity
2035.5	1004.5	2%	3.26%	16 <sup>th</sup> Annuity
2036	1036.6	2%	3.37%	17 <sup>th</sup> Annuity
2036.5	1069.7	2%	3.48%	18 <sup>th</sup> Annuity
2037	1104.0	2%	3.59%	19 <sup>th</sup> Annuity
2037.5	1139.3	2%	3.70%	20 <sup>th</sup> Annuity
2038	1175.7	2%	3.82%	21 <sup>st</sup> Annuity
2038.5	1213.3	2%	3.94%	22 <sup>nd</sup> Annuity
2039	1252.1	2%	4.07%	23 <sup>rd</sup> Annuity
2039.5	1292.2	2%	4.20%	24 <sup>th</sup> Annuity
2040	1333.5	2%	4.33%	25 <sup>th</sup> Annuity
2040.5	1376.2	2%	4.47%	26 <sup>th</sup> Annuity
2041	1420.2	2%	4.61%	27 <sup>th</sup> Annuity
2041.5	1465.6	2%	4.76%	28 <sup>th</sup> Annuity
2042	1512.5	2%	4.91%	29 <sup>th</sup> Annuity
2042.5	1560.9	2%	5.07%	30 <sup>th</sup> Annuity
<b>Total Annuity</b>		<b>60%</b>	<b>100%</b>	<b>-</b>

### 1.5.20 Revenue from Other sources

The other sources of revenue are road-side advertisement, charges from data cables along the road alignment, income from parking bay etc. The income from sources is considered as 0% of total toll revenue.

### 1.5.21 Financial Evaluation Results

#### 1.5.21.1 Project IRR

The Table 1.5.21.1 (both figures) are showing the project IRR is 10.7%. The project NPV is Rs. 483.0 Cr. at the rate 9.9% (WACC-Nominal) discount rate per year (where the target Project-IRR is 9.9%).



Detail Project report for Construction of 11.85km long twin tube, 2 lanes + 1 emergency lane each highway tunnel for connecting Thane on Eastern Express Highway to Borivali on Western Express Highway in the state of Maharashtra

**Table 1.5.21.1: Project IRR and Project NPV**

Overall project cashflows and returns	
NPV of project cashflows (Cost of Capital = 9.9%):	483.0 R cr.
<i>made up of (in present value terms)</i>	
Revenue:	8,570.4 R cr.
Operating costs:	-224.1 R cr.
Construction costs:	-11,525.6 R cr.
Tax:	-948.0 R cr.
VGf grant funding:	4,610.2 R cr.
Project IRR:	10.7% <span style="background-color: #cccccc; padding: 2px;">Update</span>

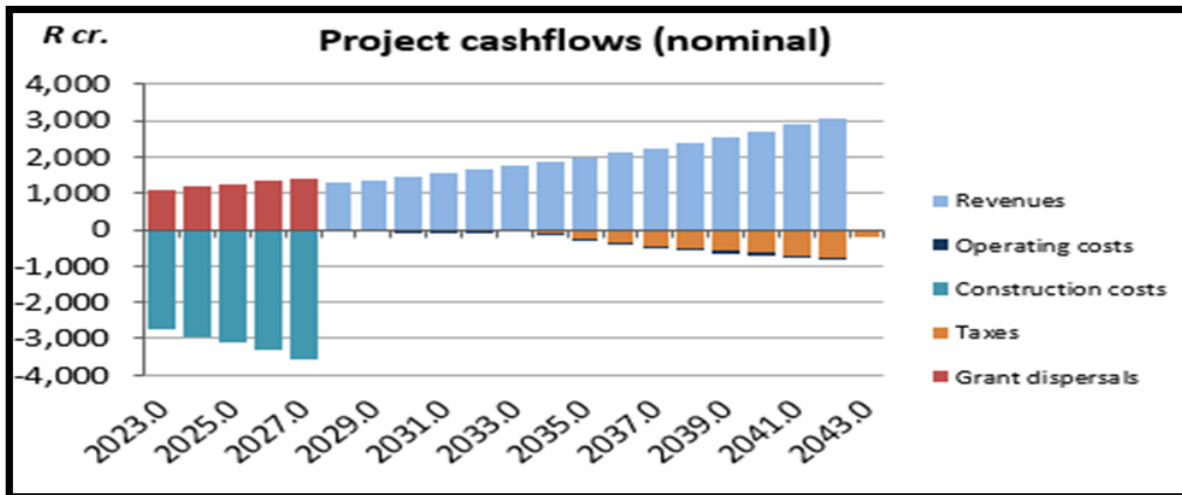

**1.5.21.2 Equity IRR**

The Equity IRR shows the rate of return for the private partner, that is, private investor. The figure 1.5.21.1 (both figures) are showing that the Equity IRR for this project is 12.1% (target Equity IRR is 12.1%) with NPV of Rs. 22.5 Cr discounting at the rate of 12% per year (interest rate). Here a target equity has been set as per the basic norms of Govt. of India in case of HAM project. The norms states that, the target equity must be an addition of 300 bps higher than the cost of debt or bank interest rate. Here, bank interest rate is 9%, hence the target equity has been fixed at 12% in case of private investor. The annuity has been set such a way that can meet with the cut-off equity IRR, that is, 12.1%.



Detail Project report for Construction of 11.85km long twin tube, 2 lanes + 1 emergency lane each highway tunnel for connecting Thane on Eastern Express Highway to Borivali on Western Express Highway in the state of Maharashtra

**Figure 1.5.21.1: Equity IRR and NPV**

	Nominal	Real
<b>Equity IRR required by private sector partners:</b>	12.1%	5.3%
<b>Terminal (real) payment to private sector partner:</b>	R cr.	0.0
<b>Private investor perspective: Shareholder cashflows and returns</b>		
NPV of shareholder cashflows (Cost of Equity = 12.0%):	22.5 R cr.	
	<i>made up of</i>	
Equity invested (present value):	-1,953.9 R cr.	
Dividends received (present value):	1,976.5 R cr.	
Equity IRR of the project:	12.1%	Update
<b>This project is viable from a private investor perspective</b>		

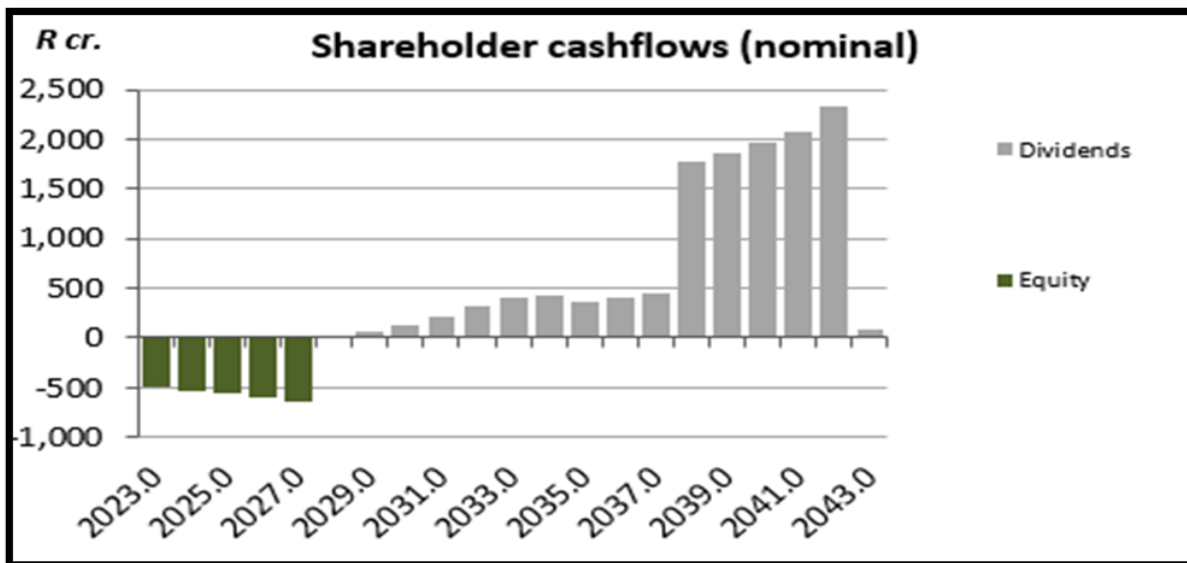

**1.5.22 Debt Service & Loan Life Coverage Ratio (DSCR & LLCR)**

The Figure 1.5.22.1 (both figures) are showing the average Debt Service Coverage Ratio (DSCR) and Loan Life Coverage Ratio (LLCR) for this project is 1.24 and 2.03 respectively, which indicates the project has strong loan repayment capacity. The Figure 1.5.22.1 of Project Ratios indicates that Net Profit Margin is always above Loan Life Coverage curve except construction period.



Detail Project report for Construction of 11.85km long twin tube, 2 lanes + 1 emergency lane each highway tunnel for connecting Thane on Eastern Express Highway to Borivali on Western Express Highway in the state of Maharashtra

Figure 1.5.22.1: Project Ratios

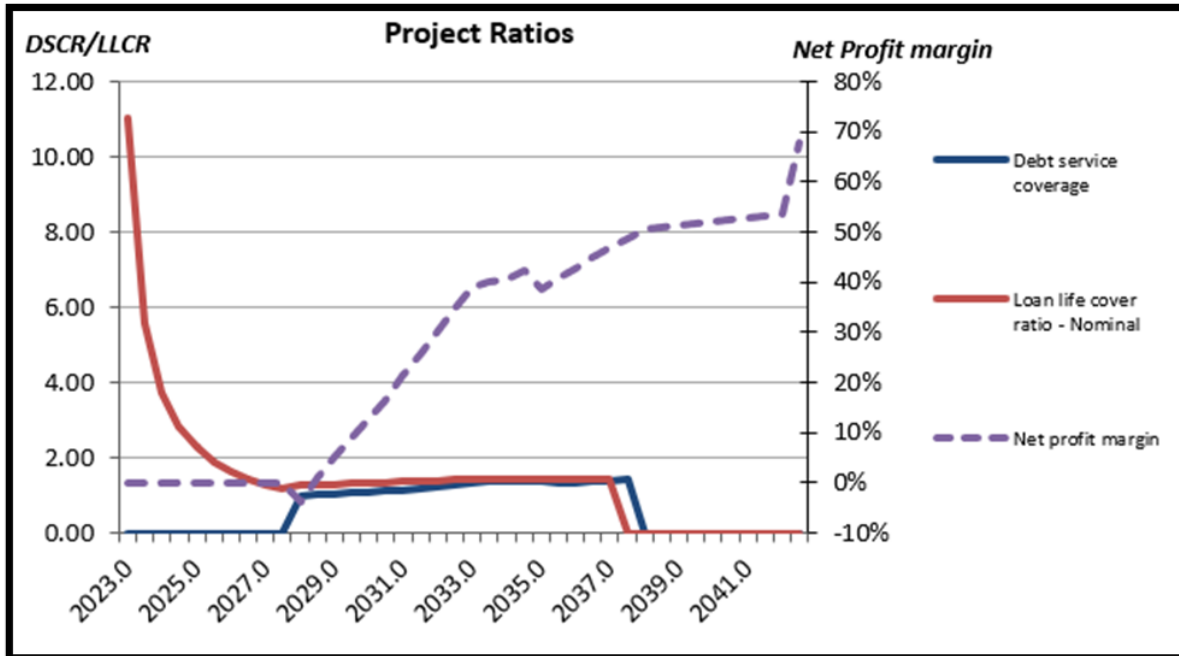

Accounting ratios	
<b>Debt service coverage</b>	
Cash available for debt service	
Total debt service	
<b>Debt service coverage</b>	
Minimum	0.98
Average	1.24
<b>Loan life cover ratio - Nominal</b>	
Cash available for debt service during loan term	
Present value of cash available	
Outstanding debt	
<b>Loan life cover ratio</b>	
Minimum	1.16
Average	2.03



Detail Project report for Construction of 11.85km long twin tube, 2 lanes + 1 emergency lane each highway tunnel for connecting Thane on Eastern Express Highway to Borivali on Western Express Highway in the state of Maharashtra

### 1.5.23 Summary of Financial Results

Table 5.23.1 is showing the summary of the Financial Analysis under the current setting of analysis under this scenario under Hybrid Annuity Model (HAM):

**Table 1.5.23.1: Summary of Financial Evaluation**

Project IRR*	Equity IRR*	Nominal WACC	Average DSCR	Average LLCR	NPV of shareholders cashflow (discounting at 12.0%)	NPV of project cashflow (discounting at WACC @ 9.9%)
10.7%	12.1%	9.9%	1.24	2.06	22.5 Cr.	483.0 Cr.

Source: Financial Analysis Model; \*Cut-off Project IRR is 9.9% (Nominal WACC) and Equity IRR is 12.0% (target rate)

The cash flow Figure 1.5.23.2 as shown below indicates that income annuity (to be paid by MMRDA) has steady rising trend except initial 5 years. The O&M costs increase over time and tax payment also increases along with revenue increase. The total cashflow shows that the source of revenue is annuity and the debt service is up to year 2037.

**Figure 1.5.23.2: Total Cash Flow**

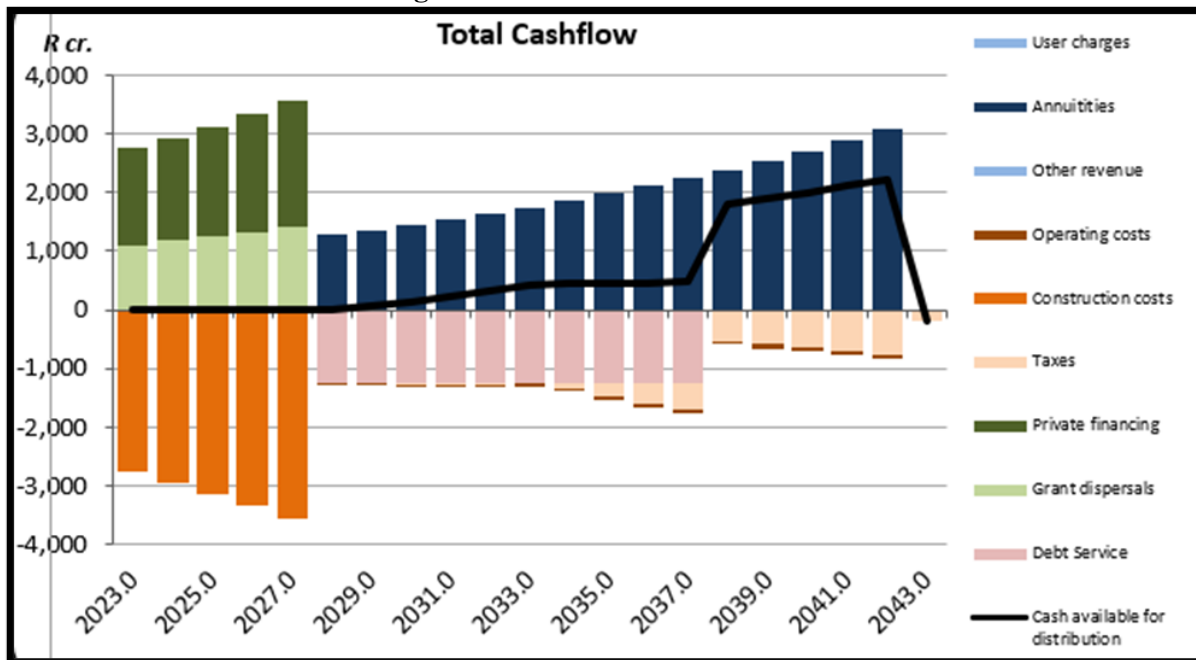



Detail Project report for Construction of 11.85km long twin tube, 2 lanes + 1 emergency lane each highway tunnel for connecting Thane on Eastern Express Highway to Borivali on Western Express Highway in the state of Maharashtra

## 1.5.23.2 Cash Flow

The table 1.5.23.2 shows the total project cashflow under the HAM setup. The entire analysis has been done on the basis of the aforesaid setup and the entire cashflow has been analyzed accordingly.

**Table 1.5.23.2: Cash Flow (Nominal) of the project (Rs. Crore)**

Years	Revenue	Operating costs	Construction costs	Taxes	Cash flow before financing	Grant dispersals	Equity	Debt	Cash flow available for debt service	Debt Service		Cash available for distribution
										Interest	Principal	
2023	0.0	0.0	-1358.1	0.0	-1358.1	543.2	244.5	570.4	0.0	0.0	0.0	0.0
2023.5	0.0	0.0	-1401.5	0.0	-1401.5	560.6	252.3	588.6	0.0	0.0	0.0	0.0
2024	0.0	0.0	-1446.4	0.0	-1446.4	578.5	260.3	607.5	0.0	0.0	0.0	0.0
2024.5	0.0	0.0	-1492.6	0.0	-1492.6	597.1	268.7	626.9	0.0	0.0	0.0	0.0
2025	0.0	0.0	-1540.4	0.0	-1540.4	616.2	277.3	647.0	0.0	0.0	0.0	0.0
2025.5	0.0	0.0	-1589.7	0.0	-1589.7	635.9	286.1	667.7	0.0	0.0	0.0	0.0
2026	0.0	0.0	-1640.5	0.0	-1640.5	656.2	295.3	689.0	0.0	0.0	0.0	0.0
2026.5	0.0	0.0	-1693.0	0.0	-1693.0	677.2	304.7	711.1	0.0	0.0	0.0	0.0
2027	0.0	0.0	-1747.1	0.0	-1747.1	698.9	314.5	733.8	0.0	0.0	0.0	0.0
2027.5	0.0	0.0	-1803.0	0.0	-1803.0	721.2	324.5	757.3	0.0	0.0	0.0	0.0
2028	626.3	-16.4	0.0	0.0	610.0	0.0	0.0	0.0	610.0	-359.2	-262.7	-12.0
2028.5	646.4	-16.9	0.0	0.0	629.5	0.0	0.0	0.0	629.5	-347.7	-274.3	7.5
2029	667.0	-17.4	0.0	-1.1	648.5	0.0	0.0	0.0	648.5	-335.6	-286.4	26.6
2029.5	688.4	-18.0	0.0	-5.9	664.5	0.0	0.0	0.0	664.5	-323.0	-299.0	42.5
2030	710.4	-18.6	0.0	-10.9	680.9	0.0	0.0	0.0	680.9	-309.8	-312.1	59.0
2030.5	733.1	-19.2	0.0	-16.1	697.9	0.0	0.0	0.0	697.9	-296.1	-325.9	75.9
2031	756.6	-19.8	0.0	-21.5	715.3	0.0	0.0	0.0	715.3	-281.7	-340.2	93.4
2031.5	780.8	-20.4	0.0	-20.5	739.9	0.0	0.0	0.0	739.9	-266.7	-355.2	118.0
2032	805.8	-21.1	0.0	-17.3	767.4	0.0	0.0	0.0	767.4	-251.1	-370.9	145.4
2032.5	831.5	-21.7	0.0	-14.3	795.5	0.0	0.0	0.0	795.5	-234.8	-387.2	173.6
2033	858.1	-22.4	0.0	-11.4	824.3	0.0	0.0	0.0	824.3	-217.7	-404.2	202.3
2033.5	885.6	-23.2	0.0	-8.7	853.7	0.0	0.0	0.0	853.7	-199.9	-422.0	231.7
2034	913.9	-23.9	0.0	-33.7	856.3	0.0	0.0	0.0	856.3	-181.3	-440.6	234.3
2034.5	943.1	-24.7	0.0	-65.1	853.4	0.0	0.0	0.0	853.4	-161.9	-460.0	231.4
2035	973.3	-25.5	0.0	-81.3	866.6	0.0	0.0	0.0	866.6	-141.7	-480.3	244.6
2035.5	1004.5	-26.3	0.0	-155.0	823.1	0.0	0.0	0.0	823.1	-120.5	-501.4	201.2
2036	1036.6	-27.1	0.0	-173.9	835.6	0.0	0.0	0.0	835.6	-98.5	-523.5	213.6
2036.5	1069.7	-28.0	0.0	-193.1	848.6	0.0	0.0	0.0	848.6	-75.4	-546.5	226.7
2037	1104.0	-28.9	0.0	-212.7	862.4	0.0	0.0	0.0	862.4	-51.4	-570.6	240.4
2037.5	1139.3	-29.8	0.0	-232.7	876.8	0.0	0.0	0.0	876.8	-26.2	-595.7	254.8
2038	1175.7	-30.7	0.0	-253.2	891.8	0.0	0.0	0.0	891.8	0.0	0.0	891.8



2038.5	1213.3	-31.7	0.0	-274.1	907.5	0.0	0.0	0.0	907.5	0.0	0.0	907.5
2039	1252.1	-32.7	0.0	-287.6	931.8	0.0	0.0	0.0	931.8	0.0	0.0	931.8
2039.5	1292.2	-33.8	0.0	-301.3	957.1	0.0	0.0	0.0	957.1	0.0	0.0	957.1
2040	1333.5	-34.9	0.0	-315.2	983.5	0.0	0.0	0.0	983.5	0.0	0.0	983.5
2040.5	1376.2	-36.0	0.0	-329.3	1010.9	0.0	0.0	0.0	1010.9	0.0	0.0	1010.9
2041	1420.2	-37.1	0.0	-343.7	1039.4	0.0	0.0	0.0	1039.4	0.0	0.0	1039.4
2041.5	1465.6	-38.3	0.0	-358.3	1069.0	0.0	0.0	0.0	1069.0	0.0	0.0	1069.0
2042	1512.5	-39.6	0.0	-373.2	1099.8	0.0	0.0	0.0	1099.8	0.0	0.0	1099.8
2042.5	1560.9	-40.8	0.0	-388.4	1131.7	0.0	0.0	0.0	1131.7	0.0	0.0	1131.7

### 1.6.0 External Support

This project is excluding of other external support, that is, other forms revenues have not been considered in this project.

### 1.7.0 Analysis of Risk

Risk areas and respective sensitivity including its relevance during the project period have been identified and indicated below.

**Table 1.7.0: Risk Profile**

Type of Risk	Risk	Cost Driver	Allocation	Treatment/Remarks
Design Risk	Time overrun due to delays in approval of detailed design	Construction Costs	MMRDA	Design of the road is complete and Construction of the road complete
	Time overrun due to delays in approval of working drawings	Construction Cost	MMRDA	
Site Risk	Land acquisition for the Project	Construction Cost	MMRDA	Agreement has been reached between MMRDA
	Site Security	Construction Cost	MMRDA & Private Party	
	Environmental	Construction Cost	Private Party	
Construction Risk	Quality assurance and quality control	Construction Cost	Private Party	-
	Achieving Construction Standards and Specifications	Construction Cost	Private Party	
	Fit for purpose manuals, approvals and statutory certificates	Construction Cost	Private Party	
	Cost overrun and delay not caused by a relief or compensation event	Construction cost	Private Party	
	Shifting of utilities	Construction Cost	Private Party	
	Delays caused by Private Party	Construction Cost	Private Party	
	Delays due to Client's changes	Construction and possibly O&M cost	MMRDA	
	Labour disputes	Construction Cost	Private Party	
	Project management /integration / delay	Construction Cost	Private Party	
	Time and costs to satisfy commissioning	Construction Cost	Private Party	
	Damage/injury to third parties	Construction Cost	Private Party	
	Adequacy of insurance	Construction Cost	Private Party	
	Sub-contractor insolvency	Construction Cost	Private Party	
Post-construction risk	Latent defects	Life Cycle Cost	Private Party	
	Workplace Health and Safety	Life Cycle Cost	Private Party	

### 1.7.1 Cost Escalation Risks

The following table 1.7.1 shows the items, responsible for cost escalation with cost drivers for this particular project under HAM settings:

**Table 1.7.1: Cost Escalation Risks**

Type of Risk	Risk	Cost Driver	Treatment/Remarks
Force Majeure Risk	Weather	Life Cycle Cost and/or Performance Payment	In case of Force Majeure event the affected party will be compensated and impacts to be mitigated as per provision of concession agreement.
	Force Majeure during operations	O&M Cost and possibly Performance Payment	
	Uninsurable risks (throughout the period)	Life Cycle Cost and/or Performance Payment	

	Political Force Majeure	O&M Cost and possibly Performance Payment	
Revenue Risk	Non-availability of road	Government Budget	
	Volume risk	O&M Cost and possibly Performance Payment	-
	Underperformance caused by tolling system	O&M Cost and possibly Performance Payment	-
O&M Risk	Increased maintenance due to traffic volume	O&M Cost and possibly Performance Payment	-
	Incorrect estimates and cost overruns	O&M Cost and possibly Performance Payment	-
	Actual operating and maintenance costs higher than anticipated	O&M Cost and possibly Performance Payment	-
	Equipment used becomes prematurely obsolescent	Life Cycle Cost	-
Performance Risk	Labour and material availability	Life Cycle Costs	
	Interface with sub-contractors	Life Cycle Costs	-
	Change in scope of service specifications by MMRDA	Life Cycle Costs	
	Expansion for traffic accommodation at ramps and interchanges due to traffic growth, or signalization	Life Cycle Costs	-
	Future interchanges or additional lanes	Life Cycle Cost	
	Damage caused by unauthorized tyres e.g. spikes	Life Cycle Costs	
	Damage/injury to third parties	Life Cycle Costs	
	Damage to works, however caused, except as excluded	Life Cycle Costs	
	Water/air/soil pollution	Life Cycle Cost and/ or Performance Payment	
	Third party claims and accidents	Life Cycle Cost and/ or Performance Payment	
	Overloaded Vehicles	Life Cycle Cost and/or Performance Payment	
	Legal loading limits increased	Life Cycle Cost and/or Performance Payment	
	Traffic accidents	Life Cycle Cost and/or Performance Payment	Responsibility of MMRDA
	Off road incidents	O&M Cost	
	Workplace Health and Safety	O&M Cost	
	Labour disputes	O&M Cost	
	Vandalism	Performance	
	Development Around Project Site Requiring Further Over Bridges or Under Passes or other Demographic Changes	Payment	
	Traffic Management	Life Cycle Cost	
	Changes in standards	Life Cycle Cost	
Market Risk	Base interest rates to Financial Close	O&M Cost and possibly Performance Payment	

	Interest spread risk to Financial close	Life Cycle Costs
	Currency fluctuations	Life Cycle Costs
	Inflation on Construction Costs	Life Cycle Cost
	Inflation on Operation, Maintenance, Rehabilitation	Life Cycle Cost
	Costs of finance on change of requirements	Life Cycle Cost
Other Market Risk	Change in law	Life Cycle Cost
	General	Life Cycle Costs
	Change in Toll operator	Life Cycle Costs
	Change in taxation	Life Cycle Costs

### 1.7.2 Sensitivity of Risks

The following table 1.7.2 shows the sensitivity of risks associated with the project and the duration to impact the project duration, mainly during construction.

**Table 1.7.2: Sensitivity of Risks**

Sl. No	Risk Area	Sensitivity	Relevance
1	Delays in land acquisition	High	0-5 Years
2	External Linkages	Low	0-5 Years
3	Financing Risk	Medium	0-5 Years
4	Planning	Medium	0-5 Years
5	Approvals	High	0-5 Years
6	Design Risk	Medium	0-5 Years
7	Construction Risk	Medium	0-5 Years
8	Technology Risk	Low	Throughout
9	O&M Risk	Medium	Throughout
10	Traffic Risk	High	Throughout
11	Payment Risk	High	Throughout
12	Financial Risk	Medium	Throughout
13	Change in Law	Low	Throughout
14	Force Majeure	Low	Throughout
15	Sponsor Risk	Medium	Throughout
16	Government event risk	Low	Throughout
17	Guarantor Risk if Government	Low	Throughout

### 1.9.1 Result & Sensitivity Analysis

The Table 1.9.1 shows the base case scenario of the analysis including the sensitivity analysis. The only possible scenario of sensitivity analysis is the possibility of overrun of the cost. Here the possibility of 10% cost overrun has been considered, that is, civil cost will increase from Rs. 1627.9 Cr. to Rs. 1790.7 Cr.:

**Table 1.9.1: Summary of Financial Evaluation**

Scenarios	Project IRR*	Equity IRR*	Nominal WACC	NPV of shareholders cashflow (Discounting at 12.0%)	NPV of project cashflow (discounting at WACC @ 9.9%)
Base Case	10.7%	12.1%	9.9%	Rs. 22.5 Cr.	Rs. 483.0 Cr.
10% Rise in Civil Cost	9.8%	10.1%	9.9%	Rs. -439.4 Cr.	Rs. -91.6 Cr.

Source: Financial Analysis Model; \*Cut-off Project IRR is 9.9% (Nominal WACC) and Equity IRR is 12.0% (target E-IRR)

### 1.10.0 Conclusion

---

It is observed from the analysis that revenue strength is significantly high in the base case analysis and the return is above the specified return level. The project is found financially sustainable from the point of view of private investor as well as the bank. Under the current possible scenarios, the project may be recommended for implementation under HAM settings.



## **Engineering, Procurement and Construction (EPC)**

### **2.1.0 Introduction and Background of the Project**

AECOM carried out financial analysis after finalization of detailed engineering and cost estimation of the aforesaid project. Series of discussions were held with MMRDA officials while exploring possible alternative options to be considered during finalization of input parameters for financial analysis. It was informed by MMRDA, that project shall be implemented through EPC. Findings of the detailed financial analysis for selected option are summarized below.

### **2.2.0 Financial Analysis for selected option**

#### **2.2.1 Total Project Cost (TPC)**

The total project cost of bypass including contingency is Rs. 12752 Cr. This is the contract value to the contractor among which civil and contingency costs are included. The construction is assumed to commence in 2023 and will be completed by the end of 2027. The new corridor including the stretch will be opened for traffic in 2028. The land acquisition cost & rehabilitation cost costs are included in total project cost since that will be borne by the Government. The final contract value of the project is Rs. 12752 Cr. The broad components of construction cost are as follows:

**Table 2.2.1.1: Total Project Cost (at 2021 price level) Rs. Cr.**

<b>Civil Cost of the corridor</b>	<b>12752</b>
<b>Contingency @ 0% of Civil Cost</b>	<b>0.0</b>
<b>Financing Cost as 0.0% of debt proportion (as there is no debt)</b>	<b>0.0</b>
<b>Interest During Construction (IDC) (as there is no third-party funding agency)</b>	<b>0.0</b>
<b>Total Project Cost</b>	<b>12752</b>

The phasing of construction has been considered as 20% 20% 20% 25% and 15% in each year of 2023, 2024, 2025, 2026 and 2027 respectively to distribute the physical work progress as per MORTH norms of construction. According to the norms by the MoRTH, eighty percent project completion should be done before last year of construction. The entire details have been depicted in Table 2.2.2.1A.

**Table 2.2.2.1A: Phasing Profile of Construction**

<b>Construction Year</b>	<b>Calendar Year</b>	<b>Construction Phasing</b>
Year 1	2023	20%
Year 2	2024	20%
Year 3	2025	20%
Year 4	2026	25%
Year 5	2027	15%

#### **2.2.2 Defect Liability Period (DLP)**

As per the EPC norms of the government, there should be a defect liability period for each of the contractor as the defect liabilities are the part of the contractor defect construction. Here the defect liability period has been considered for five consecutive years just after completion of project. The defect liability period starts in year 2028 and ends at 2029.

The Contractor shall repair and rectify the defects and deficiencies specified in this Annex-I of Schedule-E of the EPC Agreement Manual within the time limit set forth in the table below:

of Schedule-E within the time limit set forth in the tab

Nature of Defect or deficiency	
<b>ROADS</b>	
<b>(a) Carriageway and paved shoulders</b>	
(i)	Breach or blockade
(ii)	Roughness value exceeding 2,200 mm in a stretch of 1 km (as measured by a calibrated bump integrator)
(iii)	Pot holes
(iv)	Any cracks in road surface
(v)	Any depressions, rutting exceeding 10 mm in road surface
(vi)	Bleeding/skidding
(vii)	Any other defect/distress on the road
(viii)	Damage to pavement edges
(ix)	Removal of debris, dead animals

<b>Nature of Defect or deficiency</b>	
(iii)	Variation by more than 15% in the prescribed side (embankment) slopes
(iv)	Rain cuts/gullies in slope
(v)	Damage to or silting of culverts and side drains
(vi)	Desilting of drains in urban/semi- urban areas
(vii)	Railing, parapets, crash barriers
<b>(c) Road side furniture including road sign and</b>	
(i)	Damage to shape or position, poor visibility or loss of retro- reflectivity
(ii)	Painting of km stone, railing, parapets, crash barriers
(iii)	Damaged/missing signs road requiring replacement
(iv)	Damage to road mark ups
<b>(d) Road lighting</b>	
(i)	Any major failure of the system
(ii)	Faults and minor failures
<b>(e) Tunnel illumination</b>	

<b>Nature of Defect or deficiency</b>	
<b>(v)</b>	Removal of vegetation affecting sight and road structures
<b>(f) Rest area</b>	
<b>(i)</b>	Cleaning of toilets
<b>(ii)</b>	Defects in electrical, water and sa installations
<b>(g) [Toll Plaza]</b>	
<b>(h)</b>	<b>Other Project Facilities and Approach roads</b>
<b>(i)</b>	Damage in approach roads, pede facilities, truck lay- byes, bus-bays shelters, cattle crossings, [Traffic Aid Medical Aid Posts] and service roads
<b>(ii)</b>	Damaged vehicles or debris on the road
<b>(iii)</b>	Malfunctioning of the mobile cr.
<b>Bridges</b>	
<b>(a) Superstructure</b>	
<b>(i)</b>	Any damage, cracks, spalling/ scaling Temporary measures Permanent measures



Detail Project report for Construction of 11.85km long twin tube, 2 lanes + 1 emergency lane each highway tunnel for connecting Thane on Eastern Express Highway to Borivali on Western Express Highway in the state of Maharashtra

Nature of Defect or deficiency	
(i)	Deformation, damages, tilting or shifting of bearings
(e)	Joints
(i)	Malfunctioning of joints
(f)	Other items
(i)	Deforming of pads in elastomeric bearings
(ii)	Gathering of dirt in bearings and joint clogging of spouts, weep holes and drain holes
(iii)	Damage or deterioration in kerbs, par handrails and crash barriers
(iv)	Rain-cuts or erosion of banks of the slopes of approaches
(v)	Damage to wearing coat
(vi)	Damage or deterioration in approach s



### 2.2.2 Maintenance Cost

The annual maintenance costs have a different value with respect to the operational terms. The cost of the maintenance starts in the year 2030 and continues with different values over the period of analysis by authority engineers, but before that, that is, from 2028 to 2029, maintenance will be done by the contractor as this particular period will be under defects liability period. After 2029, that is, from 2030 to 2042 the maintenance will be taken care by authority. The entire analysis period has been considered for 20 years to at par the analysis with hybrid annuity model. The entire maintenance cost and schedule have been shown in Table 2.2.2:

**Table 2.2.2: Maintenance Schedule and Cost (Rs. Cr.)**

Years	Types	Shares of Contract Values	Maintenance Cost
2023	Construction Period	0.00%	0.00
2024		0.00%	0.00
2025		0.00%	0.00
2026		0.00%	0.00
2027		0.00%	0.00
2028	Defect Liability Period	0.00%	0.00
2029		0.00%	0.00
2030	Maintenance by authority	0.25%	31.88
2031		0.25%	31.88
2032		0.25%	31.88
2033		0.50%	63.76
2034		0.50%	63.76
2035		2.00%	255.04
2036		1.00%	127.52
2037		1.00%	127.52
2038		1.00%	127.52
2039		2.00%	255.04
2040		1.00%	127.52
2041		1.00%	127.52
2042		1.00%	127.52

### 2.3.1 Recovery of Cost

The Financial Analysis has been done under the set-up of EPC where toll will be collected by the authority or not, it is the discretion of them.

### 2.3.2 Basic Structure of Financial Model

The following key points have been considered for Financial Analysis:

- Construction Start Year: 2023.
- Construction End Year: 2027.
- Construction Period: 5 years.
- Defect Liability Period (DLP): 2 Years
- Defect Liability Period (Calendar Year) 2028 to 2029.
- Open for traffic for Operation from 2028.
- Analysis Period: 20 years including Construction Period (2023-2027)



- Concession Period including Construction Period: 0 Years.
- **Funding Structure:** 100% budgetary fund allocation by Govt.
- Analysis Year: November, 2022.
- Effective Debt: Equity Ratio is 0:0.
- Inflation Rate is 6.5% per annum.
- Corporate Tax Rate is 0% for entire project life.
- Cost of Debt (Interest Rate during construction and operation) is 9.0% per annum (MCLR of SBI).
- Maximum Mobilization advance is 10% of contract value.
- Maximum Equipment advance is 5% of Contract Value.
- Interest on advance mobilization is 10%, where 7% is the MCLR of SBI plus 3% slab of the Govt.
- Shifting of Utilities, Felling of Trees, dismantling of structure has been assumed at 0.25% of contract value.
- Capital Structuring: Equity from Private Investor (0%) and Debt from Bank (0%).
- Moratorium Period is 0 years.
- Effective Loan Repayment duration is 0 Years.
- Total Annual O&M Cost is Rs. 1498.4 crore over the period of analysis including major maintenance.
- The advance repayment has been made within eighty percent physical development of the project including interest as per norms.
- The cost of miscellaneous works has been considered at 0.025% of contract value at the third year of the construction.

### 2.3.3 Determination of basic toll rate

Toll will not be collected. If collected will be determined by the authority separately.

### 2.4.0 Discounts on User Fee

Will be determined by the authority separately

### 2.5.0 Financial Modeling

The financial analysis seeks to evaluate the financial performance of the project and the viability of the proposed implementation plan with given structures. The financial analysis is structured with a proprietary of financial model.

#### 2.5.1 Overview of Model

The financial model is designed to allow the testing of the financial implications of investment options at the feasibility level under EPC Setup. It indicates the resources required to construct the road project to operate and maintain, operate and maintain the required tolling infrastructure. The model generates financial cash flows, tests the ability of the project to serve its financial obligations, and indicates the key financial results of the selected scenario.

#### 2.5.2 Methodology for Analysis

The financial analysis centers on whether the cash flows from the project under a selected implementation scenario are sufficient to provide a reasonable level of return on the capital investment required to implement and maintain the project. What constitutes a reasonable level of return generally depends on who is making the investment; Government or the private sector. The



goal of this analysis is ultimately to derive the project cash flows over the forecast period for the analysis of the investment return on selected implementation structure or it shows the cheapest option for the authority when operated under EPC settings. The cash flows are calculated using a build-up approach. The analysis focuses on the annual cash flows arising from the project. The Net Present Value (NPV) of project on net cash flow has been determined in order to understand the extent of financial return available to investors or Govt.

### 2.5.3 Key Dates and Contract Period

The project and related contract(s) are expected to start in 2023 as the construction period is planned to start from 2023. The model is capable of generating financial projections up to 20 years based on the capital investment. **Table 2.5.3** below summarizes the key dates and time lines relevant to the financial projections and the analysis:

**Table 2.5.3: Assumptions on Key Dates and Durations**

Assumptions	Dates/Duration
Corridor Name	SGNP
Corridor Length	11.8 km
New Corridor Civil Cost at 2022 price level	Rs. 12752 Cr.
Construction Start Date	2023
Construction End Date	2027
Construction Period	5.0 Years
Open to Traffic	1 <sup>st</sup> January, 2028
Analysis Period	20 years (5+15)
Operating Days per Year	365 days

Source: Consultant

### 2.5.4 Total Project Cost (TPC)

The details of the total project cost (TPC) have been extensively studied and analyzed in the Section 2.2.0 of this report and Table 2.2.1 is showing that the TPC of the new corridor is Rs. 12752 crore including the toll plaza construction cost.

### 2.5.5 Stakeholders

The key stakeholders in this project are Government as the liability project cost has been borne by the Govt. itself.

#### 2.5.6 Critical Factors

The critical factors that will influence financial viability of this project are:

- Capital Cost
- Milestone payment to contractor

### 2.5.7 Length of Project considered

The present report has considered the corridor length 11.8 km for financial analysis.

### 2.5.8 Toll Efficiency

Toll will not be implemented and collected by the authority.



### **2.5.9 Financing Fee**

The financing cost has been assumed to be 0.0% of the total debt portion during the financial analysis.

### **2.5.10 Electricity and Patrolling**

To be decided separately by MMRDA.

### **2.5.11 Financial Parametric Considerations**

The financial viability analysis of the project has been formulated after taking into consideration the following key aspects:

- Operation period of maximum 20 years have been considered including construction period of 5 years.
- Project financial analysis has been carried out on yearly basis for 20 years.
- Construction period is 5 years, from 2023 to 2027.
- Defect Liability Period is 5 years, from 2028 to 2029.

### **2.5.12 Estimation of Cut-off Equity IRR**

The project Equity IRR is not valid in this context as the project is fully funded by the authority or the Govt. There is no private party involvement or participation, hence the question of Equity IRR does not arise.

### **2.5.12 Key Assumptions**

The key assumption and the parametric values of the model have been considered for this financial analysis has been mentioned in the previous section of the report. The specifications have been configured in the model and whole analysis has been carried out on the basis of that.

### **2.5.13 Debt-Equity Ratio**

Under the current setting of the analysis under EPC, the project cost has been borne by the authority. Hence, no debt-equity has been considered.

### **2.5.14 Rate of Interest**

The interest rate has been considered at 7.0% per year (plus 3% slab). The average of MCLR (Marginal Cost of Funds-based Lending Rate) of SBI has been considered, which ranges from 6.65% to 7.3%. The cost of debt has been considered at 7.0% (after rounding off). As per the norms by the MoRTH, the advance payment taken by the contractor will be chargeable at the rate of MCLR plus 300pbs. In this context that would be 7.0% plus 3.0%, that is, 10%. The advance payment must be repaid to the authority including applicable interest rate within 80% completion of the project.

<https://sbi.co.in/web/interest-rates/interest-rates/mclr-historical-data>

### **2.5.15 Tax**

Since, the project cost is inclusive of GST and applicable CESS, if any. Tax will be levied on the profit margin of the contractor as per corporate income tax regulations on the respective slabs.



### **2.5.16 Inflation Rate**

The current inflation rate has been assumed at 6.5% per annum.

### **2.5.17 Toll Plaza Cost**

Toll Plaza construction cost has not been incorporated in the civil cost.

### **2.5.18 Loan Repayment**

Since, the project has been funded by the government under EPC, the loan has not been considered in capital structuring of the project fund.

### **2.5.19 Revenue Model**

The selected mode for financial analysis, that is, EPC says there will be no revenue as the authority decides to fund the project from their own budgetary allocation. Hence, the authority neither depending on toll collection nor on annuity liability. The model rigorously analyzes the net present value of the government expenditures with respect to the project cost. In other words, the financial model shows the least cost approach of the project cost. The explanation has been detailed in following section of this report.

### **2.5.20 Revenue from Other sources**

The other sources of revenue are: road-side advertisement, charges from data cables along the road alignment, income from parking bay etc. The income from sources has not been considered.

### **2.5.21 Financial Evaluation Results**

#### **2.5.21.1 Project IRR**

Since the project has no debt ratio in capital structuring, hence the question of Project IRR does not arise.

#### **2.5.21.2 Equity IRR**

Similarly, Equity IRR is not applicable as there is no private party participation.

### **2.5.22 Debt Service & Loan Life Coverage Ratio (DSCR & LLCR)**

As there is no debt liability to authority. Hence, DSCR and LLCR is not applicable.

### **2.5.23 Summary of Financial Results**

The financial model analyzes the least cost approach as the authority decides to fund the project from their own budgetary allocation irrespective of taking loan from bank or private party associations. The prime focus of this analysis is only on the expenditure effectiveness of the authority with respect to the contract value. The entire details of the outcome have been depicted in following Table 2.5.23.1:



Detail Project report for Construction of 11.85km long twin tube, 2 lanes + 1 emergency lane each highway tunnel for connecting Thane on Eastern Express Highway to Borivali on Western Express Highway in the state of Maharashtra

**Table 2.5.23.1: Summary of Financial Evaluation**

<b>Contract Value at 2022 price level</b>	<b>Defects Liability Period</b>	<b>NPV Discounting</b>	<b>NPV of Contract Value</b>
Rs.12752 Cr.	2 Years (2028 to 2029)	at 12% per Year	Rs. 9504.7Cr.

Source: Financial Analysis Model



Detail Project report for Construction of 11.85km long twin tube, 2 lanes + 1 emergency lane each highway tunnel for connecting Thane on Eastern Express Highway to Borivali on Western Express Highway in the state of Maharashtra

## 2.5.23.2 Net Present Value of Project

This section of the report shows actual value of the project when operated and financed under EPC. It has been found that, if the project is funded by the authority without any assistance from private party, then actual project cost will be much lesser even over the entire period of analysis. A comparative study has been initiated in latter section of this report. The analysis shows that, under EPC mode of financing, the Net Present Value (here in terms of expenditure from the point of view of the authority) is Rs. 9504.7 Cr. (approx.) over entire project life and discounting at the rate of 12% per year as a social discount rate.

**Table 2.5.23.2: Total Payment by Authority to Contractor (Rs. Cr.)**

Payment by Authority to Contractor (Cr. in INR)												
Contract Price	Year	Mobilization Advance (10%)	Equipment Advance (5%)	Amount of Interest	Site Preparation cost (Amount) Shifting of Utilities, Felling of Trees, dismantling of structure (0.25% assumed)	Milestone Payment (Construction Phasing)	Amount (after adjustment of interest on advance)	Defect Liability Period	Maintenance Rate	Maintenance payment (Flexible)	Others Misc. (0.025%)	Total Amount Payable by authority
12752	2022											
	2023	1275.2	637.6	114.8	31.9	20.0%	522.8	0.0	0.0	0.0	3.2	2585.5
	2024					20.0%	2550.4					2550.4
	2025					20.0%	2550.4					2550.4
	2026					20.0%	2550.4					2550.4
	2027					20.0%	2550.4					2550.4
	2028							Year 1				0.0
	2029							Year 2				0.0
	2030								0.25%	31.9		31.9
	2031								0.25%	31.9		31.9
	2032								0.25%	31.9		31.9
	2033								0.50%	63.8		63.8
	2034								0.50%	63.8		63.8
	2035								2.00%	255.0		255.0
	2036								1.00%	127.5		127.5
	2037								1.00%	127.5		127.5
	2038								1.00%	127.5		127.5
	2039								2.00%	255.0		255.0
	2040								1.00%	127.5		127.5
	2041								1.00%	127.5		127.5
	2042								1.00%	127.5		127.5
<b>Net Present Value of expenditure @12% per year</b>												<b>9504.7</b>



*Detail Project report for Construction of 11.85km long twin tube, 2 lanes + 1 emergency lane each highway tunnel for connecting Thane on Eastern Express Highway to Borivali on Western Express Highway in the state of Maharashtra*

---

### 2.6.0 External Support

This project is excluding of other external support, that is, other forms revenues have not been considered in this project.

### 2.7.0 Analysis of Risk

Risk areas and respective sensitivity including its relevance during the project period have been identified and indicated below.

**Table 2.7.0: Risk Profile**

Type of Risk	Risk	Cost Driver	Allocation	Treatment/Remarks
Design Risk	Time overrun due to delays in approval of detailed design	Construction Costs	MMRDA	Design of the road is complete and Construction of the road complete
	Time overrun due to delays in approval of working drawings	Construction Cost		
Site Risk	Land acquisition for the Project	Construction Cost		Agreement has been reached between MMRDA
	Site Security	Construction Cost		
	Environmental	Construction Cost		
Construction Risk	Quality assurance and quality control	Construction Cost		-
	Achieving Construction Standards and Specifications	Construction Cost		
	Fit for purpose manuals, approvals and statutory certificates	Construction Cost		
	Cost overrun and delay not caused by a relief or compensation event	Construction cost		
	Shifting of utilities	Construction Cost		
	Delays caused by Private Party	Construction Cost		
	Delays due to Client's changes	Construction and possibly O&M cost		
	Labour disputes	Construction Cost		
	Project management /integration / delay	Construction Cost		
	Time and costs to satisfy commissioning	Construction Cost		
	Damage/injury to third parties	Construction Cost		
	Adequacy of insurance	Construction Cost		
Sub-contractor insolvency	Construction Cost			
Post-construction risk	Latent defects	Life Cycle Cost		
	Workplace Health and Safety	Life Cycle Cost		

### 2.7.1 Cost Escalation Risks

The following Table 2.7.1 shows the items, responsible for cost escalation with cost drivers for this particular project under HAM settings:

**Table 2.7.1: Cost Escalation Risks**

Type of Risk	Risk	Cost Driver	Treatment/Remarks
Force Majeure Risk	Weather	Life Cycle Cost and/or Performance Payment	In case of Force Majeure event the affected party will be compensated and impacts to be mitigated as per provision of concession agreement.
	Force Majeure during operations	O&M Cost and possibly Performance Payment	
	Uninsurable risks (throughout the period)	Life Cycle Cost and/or Performance Payment	
	Political Force Majeure	O&M Cost and possibly Performance	

		Payment	
Revenue Risk	Non-availability of road	Government Budget	
	Volume risk	O&M Cost and possibly Performance Payment	-
	Underperformance caused by tolling system	O&M Cost and possibly Performance Payment	-
O&M Risk	Increased maintenance due to traffic volume	O&M Cost and possibly Performance Payment	-
	Incorrect estimates and cost overruns	O&M Cost and possibly Performance Payment	-
	Actual operating and maintenance costs higher than anticipated	O&M Cost and possibly Performance Payment	-
	Equipment used becomes prematurely obsolescent	Life Cycle Cost	-
Performance Risk	Labour and material availability	Life Cycle Costs	
	Interface with sub-contractors	Life Cycle Costs	-
	Change in scope of service specifications by MMRDA	Life Cycle Costs	
	Expansion for traffic accommodation at ramps and interchanges due to traffic growth, or signalization	Life Cycle Costs	-
	Future interchanges or additional lanes	Life Cycle Cost	
	Damage caused by unauthorized tyres e.g. spikes	Life Cycle Costs	Responsibility of MMRDA
	Damage/injury to third parties	Life Cycle Costs	
	Damage to works, however caused, except as excluded	Life Cycle Costs	
	Water/air/soil pollution	Life Cycle Cost and/ or Performance Payment	
	Third party claims and accidents	Life Cycle Cost and/ or Performance Payment	
	Overloaded Vehicles	Life Cycle Cost and/or Performance Payment	
	Legal loading limits increased	Life Cycle Cost and/or Performance Payment	
	Traffic accidents	Life Cycle Cost and/or Performance Payment	
	Off road incidents	O&M Cost	
	Workplace Health and Safety	O&M Cost	
	Labour disputes	O&M Cost	
	Vandalism	Performance	
	Development Around Project Site Requiring Further Over Bridges or Under Passes or other Demographic Changes	Payment	
	Traffic Management	Life Cycle Cost	
	Changes in standards	Life Cycle Cost	
Market Risk	Base interest rates to Financial Close	O&M Cost and possibly Performance Payment	

	Interest spread risk to Financial close	Life Cycle Costs
	Currency fluctuations	Life Cycle Costs
	Inflation on Construction Costs	Life Cycle Cost
	Inflation on Operation, Maintenance, Rehabilitation	Life Cycle Cost
	Costs of finance on change of requirements	Life Cycle Cost
Other Market Risk	Change in law	Life Cycle Cost
	General	Life Cycle Costs
	Change in Toll operator	Life Cycle Costs
	Change in taxation	Life Cycle Costs

### 2.7.2 Sensitivity of Risks

The following Table 2.7.2 shows the sensitivity of risks associated with the project and the its duration to impact the project duration, mainly during construction.

**Table 2.7.2: Sensitivity of Risks**

Sl. No	Risk Area	Sensitivity	Relevance
1	Delays in land acquisition	High	0-5Years
2	External Linkages	Low	0-5Years
3	Financing Risk (if required)	Medium	0-5Years
4	Planning	Medium	0-5Years
5	Approvals	High	0-5Years
6	Design Risk	Medium	0-5Years
7	Construction Risk	Medium	0-5Years
8	Technology Risk	Low	Throughout
9	O&M Risk	Medium	Throughout
10	Traffic Risk	High	Throughout
11	Payment to contractor Risk	High	Throughout
12	Change in Law	Low	Throughout
13	Force Majeure	Low	Throughout
14	Sponsor Risk	Medium	Throughout
15	Government event risk	Low	Throughout
16	Guarantor Risk if Government	Low	Throughout

### 2.8 Sensitivity Analysis

As the project is fully funded by the authority, sensitivity is no longer applicable to this.

### 2.9 Conclusion

It has been observed rigorously that, the cost of the project at present value is much lower than the project contract value from the point of view of expenditure to the government. If government has the budgetary allocation of the project cost, then it is strongly recommended that, the authority should go for EPC option as it is much more beneficial to them.

## Comparative Analysis

### 3.1 Financial Modelling

In this financial analysis report, three financial models have been extensively analyzed and discussed extensively. The models are Build Operate Transfer—Toll, Hybrid Annuity Model and Engineering Procurement and Construction. All the models have been explored and analyzed at its maximum possible scenarios with maximum possible practice norms to reach a feasible outcome so that this particular project can be funded with maximum financial viability.

### 3.2 Financial Results

The financial results and values of its parameters show the financial outcomes and financial sustainability of the analyzed financial model, simultaneously. However, it is to be noted that BOT and HAM and EPC models are different models in terms of capital structuring, hence their analysis criteria are almost different from each other. The Table 3.2 shows a complete general comparative analysis of all the models to reach a suitable decision to make the project financially sustainable:

**Table 3.2: Comparative Structure Analysis of Financial Models**

Parameters	BOT-Toll	HAM	EPC
Private Funding	Fully	Partial	No
Govt. Funding	No	Partial	Yes
Viability Gap Funding	Yes	Yes	No
Capital Structure	Debt & Equity	Govt. Fund, Debt & Equity	Fully Govt. Funding
Revenue Source	Tolling	Annuity	Not Applicable
Equity IRR	Applicable	Applicable	Not Applicable
Project IRR	Applicable	Applicable	Not Applicable
Debt Service Coverage Ration	Applicable	Applicable	Not Applicable
Loan Life Coverage Ratio	Applicable	Applicable	Not Applicable
Construction Liability	Private Party	Private & Govt.	Govt.
Operational Liability	Private Party	Govt.	Govt.
Maintenance Liability	Private Party	Govt.	Govt.
Defect Liability Period	No	No	Yes
Loan Repayment Liability	Yes	Yes	No
Moratorium Period	Yes	Yes	No
Private Profit Margin	Yes	Yes	No
Owner of the project during operation	Private Party	Govt. & Private Party	Govt.



---

Net Present Value of Authority Expenditure	Not Applicable	₹ 11427.9 Cr.	₹ 9504.7 Cr.
--	----------------	---------------	--------------

### 3.3 Conclusion

It has been observed from the above entire analysis that project funded under EPC is beneficial to the authority since it does not include any profit margin of the private investors or banks. It is also evident from the above Table 3.2 that net present value in terms of expenditure is lowest in EPC funding mode for the project. It has been estimated that there is a savings of almost 20.2% of total contract value of said project under EPC funding. Hence, it is strongly recommended that project should be funded under EPC if govt. has its own funding source otherwise HAM is the only option.

**Build Operate and Transfer (BOT)**

**Table: Construction Cost of the corridor**

	<u>Sources</u>		<u>Uses</u>	
Equity (including finance costs)	1,912.7		0.0	Costs - design & development
Grant dispersal	4,845.4		12,751.0	Costs - civil construction
Debt	5,993.0		0.0	Costs - other
Compounded interest during construction	695.7		0.0	Contingency
			0.0	Insurance
			0.0	Financing costs
			695.7	Interest during construction
<b>Total</b>	<b>13,446.7</b>		<b>13,446.7</b>	<b>Total</b>

**Table: Phasing Profile of Construction**

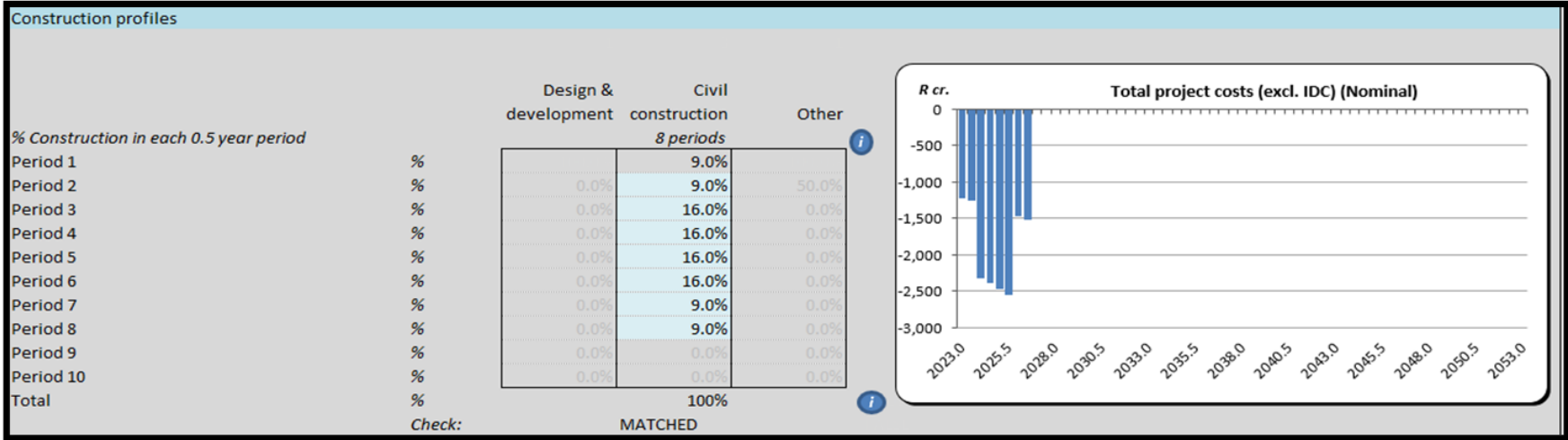

### Routine & Major Maintenance Cost

### Operating costs (OpEx)

#### Fixed OpEx

Annual costs	Existing Assets	New Assets
Cost phase starting:		2027.0

#### Unit cost inputs:

Routine maintenance	R Ik./km/ln	2.00
Toll collection expenses	R Ik./plaza	990.00
Other office expenses	R Ik.	3.00
Patrolling expenses	R Ik./km	1.20
Electricity expenses	R Ik./km	0.60

#### Total annual opex costs:

Routine maintenance	R Ik.	1416.00
Toll collection expenses	R Ik.	990.00

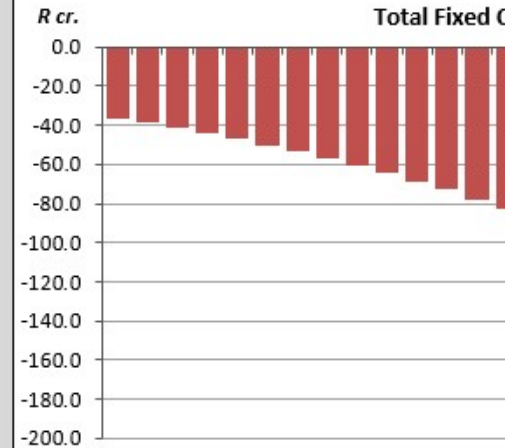

**Table: Annual OpEx of Toll Collection (Rs. Lakh)**

Expense Type	Unit Cost	No. Shifts	Total Cost in Lakh	Total Cost per toll booth	Total cost for 24 toll booths at a time (up+down)
<b>Toll collection expenses</b>	R lk./plaza				
1.Toll Collector	3 persons	3	40.0	55.0	990.0
2.Toll Attendant	3 persons	3			
3.Barrier man	3 persons	3			
4.Channelizer	3 persons	3			
5.Gun man	3 persons	3			
<b>Administrative Officer</b>	1 person	1	5.0		
<b>Plaza Manager</b>	1 person	1	6.0		
<b>Accountant</b>	1 person	1	4.0		
<b>Patrolling expenses &amp; Security Officers</b>	-	-	-	-	66.86
<b>Electricity expenses</b> Electrician	-	-	-	-	33.43
<b>Other office expenses</b>	R lk.				
1.Safaiwala	1 person	1	-	-	3.0
2.Peon	1 person	1			
<b>Total Annual Operational Expenditure in Lakh of Rupees</b>				-	<b>1093.29</b>
<b>Total Annual Operational Expenditure in crore of Rupees</b>				-	<b>10.93</b>

**Toll-able Traffic**

### Traffic forecast

**Select the tolled vehicle categories**

- Car/Jeep
- LCV / Mini-bus
- Std. Bus/2 Axle Truck
- 3 Axle Trucks
- MAV (4-6 Axle)

**Road parameters (existing + new)** Parameters OK

Total route-length 118.0 km i

Number of lanes 6

Number of toll plazas 1

**Road parameters (existing road only)**

Total route-length km

Number of shoulder lanes

Number of toll plazas

---

**Traffic in Base Year, 2023 (for toll roads)** i

Vehicle type	Total base year Vehicle km	Booth number:
		<b>1</b>
		<b>Annual Average Daily Traffic (AADT):</b>
Car/Jeep	1,108,191,100	25,730
LCV / Mini-bus	170,471,060	3,958
Std. Bus/2 Axle Truck	134,550,680	3,124
3 Axle Trucks	46,774,020	1,086
MAV (4-6 Axle)	37,384,760	868

Traffic growth		Initial	2 <sup>nd</sup> Phase	3 <sup>rd</sup> Phase
<i>Demand phase</i>		2027.0	2033.0	2039.0
<i>CAGR</i>				
Car/Jeep	5.2%	5.8%	5.4%	4.8%
LCV / Mini-bus	7.5%	8.2%	7.9%	7.0%
Std. Bus/2 Axle Truck	7.1%	7.3%	7.0%	7.0%
3 Axle Trucks	7.5%	8.2%	7.9%	7.0%
MAV (4-6 Axle)	7.5%	8.2%	7.9%	7.0%

#### Basic Structure of Financial Model

- Construction Start Year: 2023.
- Construction End Year: 2026.
- Construction Period: 4.0 Years.
- Open for traffic for Commercial Operation from 2027.
- Analysis Period: 20 years including Construction Period (2023-2052)
- PPP Concession Period including Construction Period: 30 Years.
- **Funding Structure:** Grant-38%, Debt-47% and Equity-15%, Loan Term-22 Years.
- Analysis Year: November, 2022.
- Inflation Rate is 6.5% per annum.
- Cost of Debt (Bank Interest Rate during construction and operation) is 6.0% per annum.
- Weighted Average Capital Cost (Nominal) is 6.7%.
- Cost of Equity is 9.0% per annum.
- Moratorium Period is 4.0 years.
- Effective Loan Repayment duration is 18 Years.
- Annual O&M Cost including Heavy Maintenance is Rs. 26.21 crore per year.

### Determination of basic toll rate

Toll Rate has been determined according to “Maharashtra Public Private Participation Policy—2014”. Calculation of fee amount, to be charged from road users of SGNP, is as per actual road and equivalent road length of proposed structure portion of ten times.

**Table: Determination of Base Toll Rate as per “Maharashtra Public Private Participation Policy—2014”**

	User fee for 11.8 km of structure	2022				
		Car	LCV/Mini Bus	Bus/ 2-Axle Truck	MAV (3 axle)	MAV (4-6 axle)
Revised Base Rate	Base Rate	0.50	1.05	2.20	2.40	3.45
	Fixed Increase	0.23	0.47	0.99	1.08	1.55
	Revised Base Rate	0.73	1.52	3.19	3.48	5.00
Road Length (km)	Road length in km (excluding length of bypass if any)	11.80	11.80	11.80	11.80	11.80
	Structure on road length in km	11.80	11.80	11.80	11.80	11.80
	Net road length without structure	0.00	0.00	0.00	0.00	0.00
Structure Length (km)	Total Length of structure >60m	11.80	11.80	11.80	11.80	11.80
	Converted equivalent road length for structure in km>60m	118.00	118.00	118.00	118.00	118.00
Toll Rate Calculation	Total Tollable road length in km	<b>118.00</b>	<b>118.00</b>	<b>118.00</b>	<b>118.00</b>	<b>118.00</b>
	Fee for the road stretches	123.55	259.45	543.61	593.03	852.49
	Fee for the bypass	0.00	0.00	0.00	0.00	0.00
	Fee for the whole section	123.55	259.45	543.61	593.03	852.49
	<b>Rounded off fee for single trip</b>	<b>125</b>	<b>260</b>	<b>545</b>	<b>595</b>	<b>850</b>

	User fee for 11.8 km of structure	2027				
		Car	LCV/Mini Bus	Bus/ 2-Axle Truck	MAV (3 axle)	MAV (4-6 axle)
Revised Base Rate	Base Rate	0.50	1.05	2.20	2.40	3.45
	Fixed Increase (20*3%)	0.30	0.63	1.32	1.44	2.07
	Revised Base Rate	0.80	1.68	3.52	3.84	5.52
Road Length (km)	Road length in km (excluding length of bypass if any)	11.80	11.80	11.80	11.80	11.80
	Structure on road length in km	11.80	11.80	11.80	11.80	11.80
	Net road length without structure	0.00	0.00	0.00	0.00	0.00
Structure Length	Total Length of structure >60m	11.80	11.80	11.80	11.80	11.80
	Converted equivalent road length for structure in	118.00	118.00	118.00	118.00	118.00

(km)	km>60m					
Toll Rate Calculation	Total tollable road length in km	<b>118.00</b>	<b>118.00</b>	<b>118.00</b>	<b>118.00</b>	<b>118.00</b>
	Fee for the road stretches	136.33	286.29	599.85	654.38	940.67
	Fee for the bypass	0.00	0.00	0.00	0.00	0.00
	Fee for the whole section	136.33	286.29	599.85	654.38	940.67
<b>Rounded off fee for single trip</b>		<b>135</b>	<b>285</b>	<b>600</b>	<b>655</b>	<b>940</b>
User fee for 6.8 km of structure		<b>2035</b>				
		Car	LCV/Mini Bus	Bus/ 2-Axle Truck	MAV (3 axle)	MAV (4-6 axle)
Revised Base Rate	Base Rate	0.50	1.05	2.20	2.40	3.45
	Fixed Increase (28*3%)	0.42	0.88	1.85	2.02	2.90
	Revised Base Rate	0.92	1.93	4.05	4.42	6.35
Road Length (km)	Road length in km (excluding length of bypass if any)	11.80	11.80	11.80	11.80	11.80
	Structure on road length in km	11.80	11.80	11.80	11.80	11.80
	Net road length without structure	0.00	0.00	0.00	0.00	0.00
Structure Length (km)	Total Length of structure >60m	11.80	11.80	11.80	11.80	11.80
	Converted equivalent road length for structure in km>60m	118.00	118.00	118.00	118.00	118.00
Toll Rate Calculation	Total tollable road length in km	<b>118.00</b>	<b>118.00</b>	<b>118.00</b>	<b>118.00</b>	<b>118.00</b>
	Fee for the road stretches	156.78	329.24	689.83	752.54	1081.78
	Fee for the bypass	0.00	0.00	0.00	0.00	0.00
	Fee for the whole section	156.78	329.24	689.83	752.54	1081.78
	<b>Rounded off fee for single trip</b>	<b>155</b>	<b>330</b>	<b>690</b>	<b>755</b>	<b>1080</b>

User fee for 6.8 km of structure		<b>2043</b>				
		Car	LCV/Mini Bus	Bus/ 2-Axle Truck	MAV (3 axle)	MAV (4-6 axle)
Revised Base Rate	Base Rate	0.50	1.05	2.20	2.40	3.45
	Fixed Increase (36*3%)	0.54	1.13	2.38	2.59	3.73
	Revised Base Rate	1.04	2.18	4.58	4.99	7.18
Road Length (km)	Road length in km (excluding length of bypass if any)	11.80	11.80	11.80	11.80	11.80
	Structure on road length in km	11.80	11.80	11.80	11.80	11.80
	Net road length without structure	0.00	0.00	0.00	0.00	0.00

Structure Length (km)	Total Length of structure >60m	11.80	11.80	11.80	11.80	11.80
	Converted equivalent road length for structure in km>60m	118.00	118.00	118.00	118.00	118.00
Toll Rate Calculation	Total tollable road length in km	118.00	118.00	118.00	118.00	118.00
	Fee for the road stretches	177.23	372.18	779.81	850.70	1222.88
	Fee for the bypass	0.00	0.00	0.00	0.00	0.00
	Fee for the whole section	177.23	372.18	779.81	850.70	1222.88
	<b>Rounded off fee for single trip</b>	<b>175</b>	<b>370</b>	<b>780</b>	<b>850</b>	<b>1225</b>

#### Indexing of Toll Rates

Indexing allows the operators to adjust toll rates to new price level. The toll indexation will be according to the “**Maharashtra Public Private Participation Policy—2014**”, by using Wholesale Price Index as published by Reserve Bank of India in each year. Toll rate adjustment will be done periodically that is in each year as prescribed by toll policy without compounding but interim adjustment may be necessary sometime with prior permission from MMRDA, if the requirement arises.

$$\text{Applicable Toll Rate} = \text{Base Toll Rate} + \text{Base Toll Rate} * \left[ \frac{\text{WPI A} - \text{WPI B}}{\text{WPI B}} \right] * 0.4$$

#### Revenue Model

Figure: Revenue from Road User Charges (Nominal)

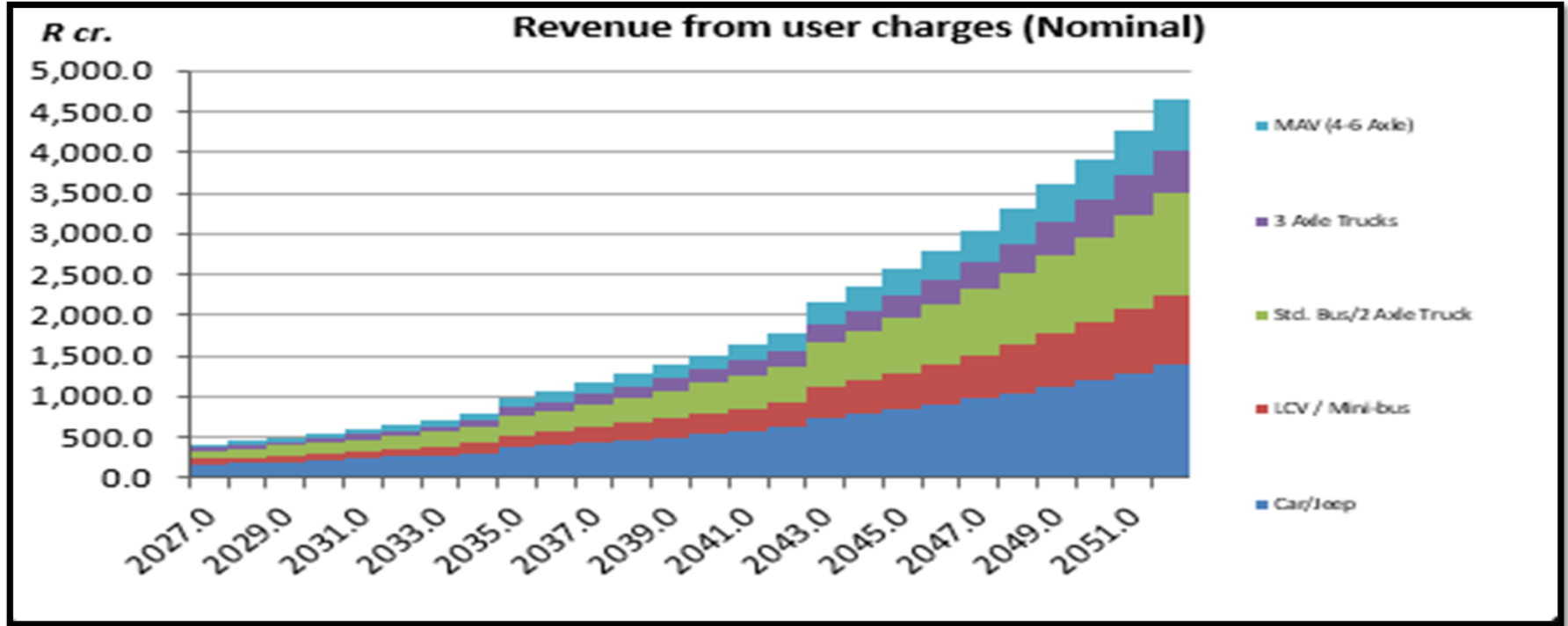

Source: Financial Model

**Financial Evaluation Results**

	Nominal	Real
<b>Equity IRR required by private sector partners:</b>	9.0%	2.3%
<b>Terminal (real) payment to private sector partner:</b>	R cr.	0.0
<b>Private investor perspective: Shareholder cashflows and returns</b>		
NPV of shareholder cashflows (Cost of Equity = 9.0%):	425.5	R cr.
<i>made up of</i>		
Equity invested (present value):	-1,794.9	R cr.
Dividends received (present value):	2,220.4	R cr.
<b>Equity IRR of the project:</b>	10.0%	Update
<b>This project is viable from a private investor perspective</b>		
<b>Overall project cashflows and returns</b>		
NPV of project cashflows (Cost of Capital = 6.7%):	1,660.8	R cr.
<i>made up of (in present value terms)</i>		
Revenue:	12,099.1	R cr.
Operating costs:	-656.5	R cr.
Construction costs:	-12,677.0	R cr.
Tax:	-1,922.0	R cr.
VGF grant funding:	4,817.3	R cr.
<b>Project IRR:</b>	8.0%	Update

Project IRR 8.0% and Equity IRR 10.0%.

Debt Service & Loan Life Coverage Ratio (DSCR & LLCR)

The following Figure showing the average Debt Service Coverage Ratio (DSCR) and Loan Life Coverage Ratio (LLCR) for this project is 1.26 and 2.01 respectively, which indicates the project has strong loan repayment capacity.

**Figure: Project Ratios**

<b>Debt service coverage</b>	
Cash available for debt service	
Total debt service	
<b>Debt service coverage</b>	
Minimum	0.51
Average	1.26
<b>Loan life cover ratio - Nominal</b>	
Cash available for debt service during loan term	
Present value of cash available	
Outstanding debt	
<b>Loan life cover ratio</b>	
Minimum	1.07
Average	2.01

Nominal Cash Flow

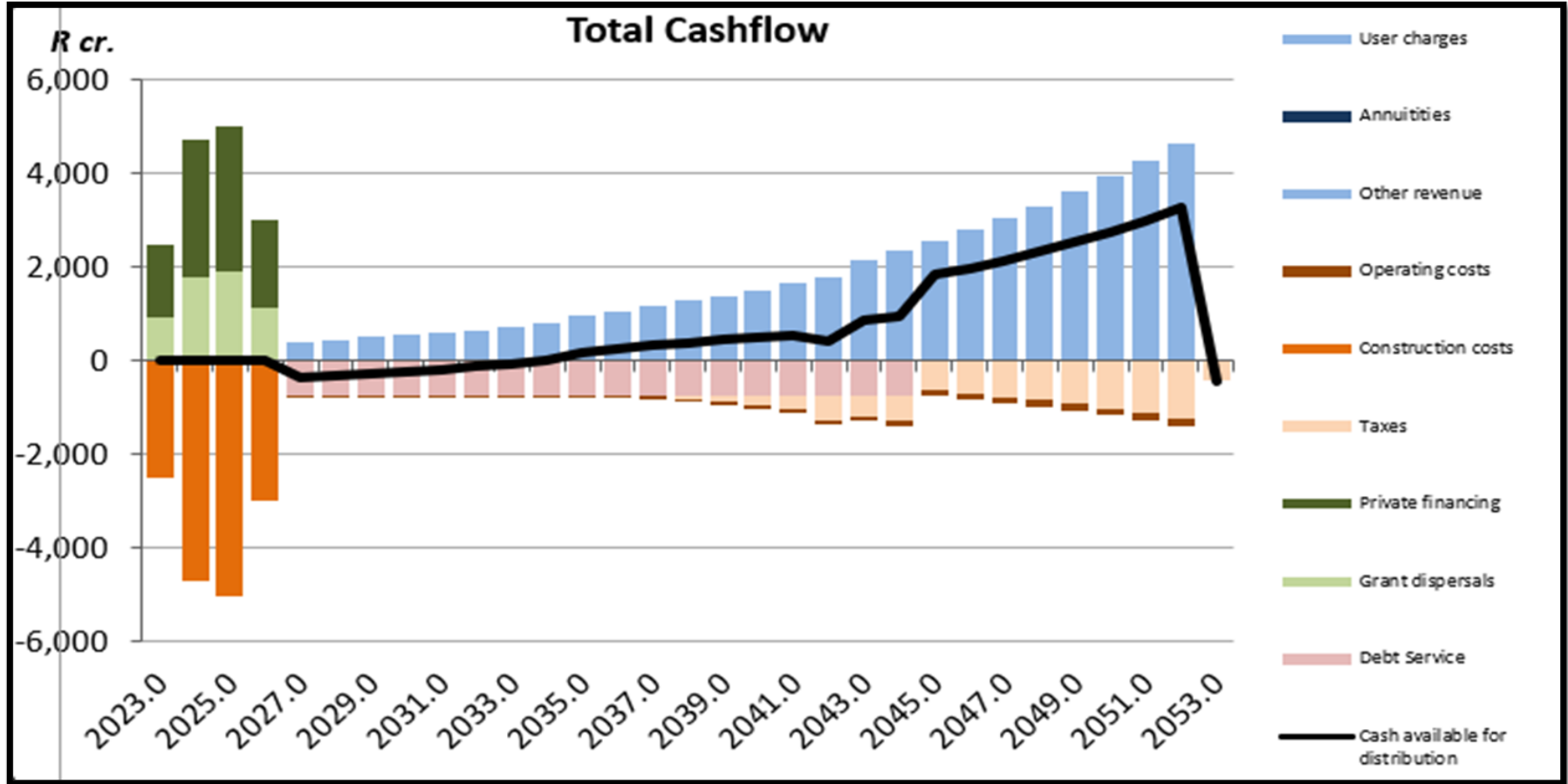

Table: Cash Flow (Nominal) of the project (Rs. Crore)



Detail Project report for Construction of 11.85km long twin tube, 2 lanes + 1 emergency lane each highway tunnel for connecting Thane on Eastern Express Highway to Borivali on Western Express Highway in the state of Maharashtra



Years	Revenue	O&M Cost	Construction costs	Taxes	Cash flow before financing	Grant dispersals	Equity	Debt	Cash flow available for debt service	Bank Loan Service		Cash available for distribution
										Interest	Principal	
2023	0.0	0.0	-1222.2	0.0	-1222.2	464.4	183.3	574.4	0.0	0.0	0.0	0.0
2023.5	0.0	0.0	-1261.3	0.0	-1261.3	479.3	189.2	592.8	0.0	0.0	0.0	0.0
2024	0.0	0.0	-2314.0	0.0	-2314.0	879.3	347.1	1087.6	0.0	0.0	0.0	0.0
2024.5	0.0	0.0	-2388.0	0.0	-2388.0	907.4	358.2	1122.4	0.0	0.0	0.0	0.0
2025	0.0	0.0	-2464.4	0.0	-2464.4	936.5	369.7	1158.3	0.0	0.0	0.0	0.0
2025.5	0.0	0.0	-2543.2	0.0	-2543.2	966.4	381.5	1195.3	0.0	0.0	0.0	0.0
2026	0.0	0.0	-1476.3	0.0	-1476.3	561.0	221.5	693.9	0.0	0.0	0.0	0.0
2026.5	0.0	0.0	-1523.6	0.0	-1523.6	579.0	228.5	716.1	0.0	0.0	0.0	0.0
2027	202.8	-18.0	0.0	0.0	184.8	0.0	0.0	0.0	184.8	-236.7	-127.7	-179.6
2027.5	212.2	-18.5	0.0	0.0	193.7	0.0	0.0	0.0	193.7	-233.0	-131.4	-170.7
2028	222.2	-19.1	0.0	0.0	203.0	0.0	0.0	0.0	203.0	-229.1	-135.3	-161.4
2028.5	232.5	-19.7	0.0	0.0	212.8	0.0	0.0	0.0	212.8	-225.1	-139.3	-151.6
2029	243.4	-20.4	0.0	0.0	223.1	0.0	0.0	0.0	223.1	-221.0	-143.4	-141.3
2029.5	254.8	-21.0	0.0	0.0	233.8	0.0	0.0	0.0	233.8	-216.7	-147.7	-130.6
2030	266.7	-21.7	0.0	0.0	245.1	0.0	0.0	0.0	245.1	-212.4	-152.1	-119.3
2030.5	279.2	-22.4	0.0	0.0	256.9	0.0	0.0	0.0	256.9	-207.9	-156.5	-107.5
2031	292.3	-23.1	0.0	0.0	269.2	0.0	0.0	0.0	269.2	-203.2	-161.2	-95.2
2031.5	306.0	-23.8	0.0	0.0	282.2	0.0	0.0	0.0	282.2	-198.5	-165.9	-82.2
2032	320.4	-24.6	0.0	0.0	295.8	0.0	0.0	0.0	295.8	-193.6	-170.8	-68.6
2032.5	335.4	-25.4	0.0	0.0	310.1	0.0	0.0	0.0	310.1	-188.5	-175.9	-54.3
2033	351.2	-26.2	0.0	0.0	325.0	0.0	0.0	0.0	325.0	-183.3	-181.1	-39.4
2033.5	367.1	-27.0	0.0	0.0	340.1	0.0	0.0	0.0	340.1	-178.0	-186.5	-24.3
2034	383.8	-27.9	0.0	0.0	355.9	0.0	0.0	0.0	355.9	-172.4	-192.0	-8.5
<b>2034.5</b>	<b>401.2</b>	<b>-28.8</b>	<b>0.0</b>	<b>0.0</b>	<b>372.4</b>	<b>0.0</b>	<b>0.0</b>	<b>0.0</b>	<b>372.4</b>	<b>-166.8</b>	<b>-197.6</b>	<b>8.0</b>
2035	475.9	-29.7	0.0	0.0	446.2	0.0	0.0	0.0	446.2	-160.9	-203.5	81.8
2035.5	497.6	-30.7	0.0	5.5	472.4	0.0	0.0	0.0	472.4	-154.9	-209.5	108.0
2036	520.2	-31.7	0.0	2.2	490.7	0.0	0.0	0.0	490.7	-148.7	-215.7	126.3
2036.5	543.9	-32.7	0.0	-3.5	507.7	0.0	0.0	0.0	507.7	-142.3	-222.1	143.3
2037	568.6	-33.7	0.0	-11.3	523.6	0.0	0.0	0.0	523.6	-135.8	-228.6	159.2



Detail Project report for Construction of 11.85km long twin tube, 2 lanes + 1 emergency lane each highway tunnel for connecting Thane on Eastern Express Highway to Borivali on Western Express Highway in the state of Maharashtra



2037.5	594.6	-34.8	0.0	-21.1	538.6	0.0	0.0	0.0	538.6	-129.0	-235.4	174.2
2038	621.7	-35.9	0.0	-32.9	552.9	0.0	0.0	0.0	552.9	-122.1	-242.3	188.5
2038.5	650.0	-37.0	0.0	-46.5	566.5	0.0	0.0	0.0	566.5	-114.9	-249.5	202.1
2039	679.7	-38.2	0.0	-61.9	579.6	0.0	0.0	0.0	579.6	-107.5	-256.9	215.2
2039.5	708.9	-39.5	0.0	-78.9	590.5	0.0	0.0	0.0	590.5	-99.9	-264.5	226.1
2040	739.3	-40.7	0.0	-97.5	601.1	0.0	0.0	0.0	601.1	-92.1	-272.3	236.7
2040.5	771.0	-42.0	0.0	-117.5	611.5	0.0	0.0	0.0	611.5	-84.0	-280.4	247.1
2041	804.2	-43.4	0.0	-139.0	621.8	0.0	0.0	0.0	621.8	-75.8	-288.6	257.4
2041.5	838.7	-44.8	0.0	-161.8	632.2	0.0	0.0	0.0	632.2	-67.2	-297.2	267.7
2042	874.8	-46.2	0.0	-185.9	642.7	0.0	0.0	0.0	642.7	-58.4	-306.0	278.3
2042.5	912.5	-47.7	0.0	-353.2	511.6	0.0	0.0	0.0	511.6	-49.4	-315.0	147.2
2043	1061.0	-49.2	0.0	-206.5	805.4	0.0	0.0	0.0	805.4	-40.1	-324.3	441.0
2043.5	1106.8	-50.8	0.0	-253.4	802.6	0.0	0.0	0.0	802.6	-30.5	-333.9	438.2
2044	1154.5	-52.4	0.0	-270.4	831.7	0.0	0.0	0.0	831.7	-20.6	-343.8	467.3
2044.5	1204.3	-54.1	0.0	-288.0	862.2	0.0	0.0	0.0	862.2	-10.5	-353.9	497.8
2045	1256.3	-55.8	0.0	-306.2	894.3	0.0	0.0	0.0	894.3	0.0	0.0	894.3
2045.5	1310.5	-57.6	0.0	-325.1	927.9	0.0	0.0	0.0	927.9	0.0	0.0	927.9
2046	1367.2	-59.4	0.0	-341.4	966.3	0.0	0.0	0.0	966.3	0.0	0.0	966.3
2046.5	1426.3	-61.3	0.0	-358.4	1006.5	0.0	0.0	0.0	1006.5	0.0	0.0	1006.5
2047	1488.0	-63.3	0.0	-376.1	1048.6	0.0	0.0	0.0	1048.6	0.0	0.0	1048.6
2047.5	1552.4	-65.3	0.0	-394.4	1092.7	0.0	0.0	0.0	1092.7	0.0	0.0	1092.7
2048	1619.7	-67.4	0.0	-413.5	1138.8	0.0	0.0	0.0	1138.8	0.0	0.0	1138.8
2048.5	1689.9	-69.5	0.0	-433.3	1187.1	0.0	0.0	0.0	1187.1	0.0	0.0	1187.1
2049	1763.2	-71.8	0.0	-453.8	1237.5	0.0	0.0	0.0	1237.5	0.0	0.0	1237.5
2049.5	1839.7	-74.1	0.0	-475.3	1290.3	0.0	0.0	0.0	1290.3	0.0	0.0	1290.3
2050	1919.5	-76.4	0.0	-497.6	1345.5	0.0	0.0	0.0	1345.5	0.0	0.0	1345.5
2050.5	2002.9	-78.9	0.0	-520.8	1403.3	0.0	0.0	0.0	1403.3	0.0	0.0	1403.3
2051	2090.0	-81.4	0.0	-544.9	1463.6	0.0	0.0	0.0	1463.6	0.0	0.0	1463.6
2051.5	2180.8	-84.0	0.0	-570.1	1526.8	0.0	0.0	0.0	1526.8	0.0	0.0	1526.8
2052	2275.7	-86.7	0.0	-596.3	1592.7	0.0	0.0	0.0	1592.7	0.0	0.0	1592.7
2052.5	2374.8	-89.5	0.0	-623.6	1661.7	0.0	0.0	0.0	1661.7	0.0	0.0	1661.7

## Chapter 10 -Operation and Maintenance of the project

Operations and maintenance should ensure that the level of safety in tunnel is upheld by maintaining the assumed functional safety and requirements. The overall aim of operation and maintenance of a road tunnel will be to maintain a specified level of safety for the road users, with an optimum level of expenditure and without adverse environmental effect.

The maintenance shall be planned and performed in such a way that the operational assumptions made at the design stage remain validated throughout the long operational life of the road tunnel. The Operation and Maintenance activities of the road tunnel shall be planned to achieve the following objectives:

- Safety of the road users
- Ensuring free flow of traffic
- Operational economy
- Dealing with abnormal situations

### 10.1 Operations

In order to successfully and efficiently operate and manage a road tunnels, operational tasks and the responsible body for carrying them out, need to be established in order to ensure that all actions required are handled in a consistent and safe way. The level of safety provided for tunnel users is highly dependent upon the specific characteristics of the tunnel, but it also depends strongly on operational procedures and the people who oversee the tunnel.

**For carrying out the operations, MMRDA to procure a different contractor**

### 10.2 Maintenance

Establishing procedures and practices for the inspection, documentation, for various elements of the road project. This manual will be used as part of developing a comprehensive inspection and maintenance program. The preliminary research performed indicates that a majority of tunnel owners believe there is a need to develop guidance for procedures for managing tunnel activities that could be readily implemented

Maintenance obligation of the Contractors:

The contractors engaged during the project construction will maintain the works for a period of 2 (Two) years during the defect liability period or as stipulated in the contract.

Without efficient operation and maintenance, it is not possible to guarantee the safety of road tunnel users and inadequate attention to maintenance leads to an un acceptable tunnel life/Project sustainability and also proper operation of road facilities is a major consideration in reaching the design life.

As far as possible, operations and maintenance should be carried out systematically and at appropriate intervals. The life cycle consideration of both technical equipment and construction should be taken into account when determining maintenance routines. Optimised maintenance frequency will reduce the probability for costly replacements.

### 10.3 Maintenance Manual:

In order to ensure that maintenance is carried out systematically, a maintenance manual should be prepared such that some routines are followed by everyone involved in operation and maintenance of the project.

This should also include but not limited to the

- Maintenance of construction elements
- Maintenance of Road surface and its elements
- Maintenance of equipment
- Maintenance of technical installations

The Manual should contain precise description of service routines and the functions of individual elements, procedures for control and testing.

For each element the manual shall contain the following information.

- Description of the equipment
- Function of the equipment
- Functional specifications
- Requirements for operating standards
- Description of possible faults arising
- Description of parts to be maintained
- Service and separation procedures.

And should also include recommended procedures made by the suppliers, information from suppliers In addition, functional Control and status reports should be used.

#### **Functional control:**

1. Is designed to ensure that the construction elements function according to the given specifications. The aim is to ensure that the components fulfil the functional safety.
2. To ensure that the equipment and installations shall function as required at all times, Manual or automatic routines be specified.

An example of the functional control that is carried out for some of the construction elements includes:

- Tunnel Portals
- Cut and cover structures
- Tunnels and seals
- Pumping stations
- Buildings for all technical equipment.

#### **Status Reports**

Status reports for structural elements should include but not limited to the following:

- Discolouring of the surface
- Surface dampness
- Leakage points

- Cracks and Joints
- Peeling cement
- Cracks with water seepage
- Salt accumulation / efflorescence
- Rusting marks/stains

Similarly , status report of the equipment should include the equipment's for the various constructions and installations in the tunnel .

Systematic planning shall include one or more of the following maintenance procedures in terms of maintenance for all elements of the project viz. Bored tunnels, Cut & Cover tunnels, Ramps, viaducts and all other services/Utilities.

1) Routine maintenance

Routine maintenance is defined as maintenance activities which are carried out regularly. Tasks can be performed daily, weekly, monthly, or annually. Routine maintenance typically includes regular inspections and machine, assets & equipment servicing. The primary goal is to identify problems on an ongoing basis before they result in equipment failure.

2) Preventive Maintenance

preventive maintenance occurs before a problem presents itself, which increases the longevity of assets/equipment

3) Reactive maintenance

Reactive maintenance takes place after a problem has occurred

4) Periodic Maintenance

5) Lifecycle maintenance

All operational and maintenance tasks carried out, both planned and unforeseen, should be documented with appropriate program for management, operations and maintenance.

#### 10.4 O & M activities for tunnels:

Major O & M activities are classified as follows:

- 1) Inspection
- 2) Maintenance; tunnel structure and facilities
- 3) Status Reports
- 4) Monitoring of traffic movement, traffic accident, fire incident, etc.
- 5) Immediate actions when some incidents are found or reported
- 6) Vehicle Control (vehicles carrying hazardous materials, vehicle height, and overloaded trucks.)

#### Inspection

Inspection of a tunnel must be undertaken daily by an inspection team, and check the following:

- Facilities inside the tunnel such as lighting facility, emergency telephones, public address system, ventilation system etc. are properly functioning.
- Cleanliness of the tunnel wall, road surface, facilities, etc.
- Any cracks on concrete lining and pavement, water seepage from concrete lining, etc.
- Drainage facility (no clogging, etc.)
- Deformation of the tunnel arch.

Typical Inspection items for civil work components and electrical/communication facilities are listed below

Component		Inspection Items	
Civil work Component	Road Surface	Pavement (1) Surface roughness, (2) Cracks, (3) Joint failure, (4) Heaving, (5) Pumping, (6) Local settlement	
	Tunnel Portion	Tunnel Portal	(1) Cracks, (2) Drainage, Water Flow, (3) Any deformation, (4) Slope condition
		Lining	(1) Cracks, (2) Leakage of water, (3) Free Lime, (4) Delamination, (5) Difference at a joint
		Interior Wall	(1) Damage, (2) Damages to the accessories
		Drainage	(1) Clogging, (2) Damage
	Fire Boards		
	Jet Fans	Abnormal noise, vibration, cable connection and voltage. Interlocking with visibility index (VI) sensors and carbon dioxide (CO) sensors.	

Electrical/ Mechanical/ Communication Component	Lighting Facilities	Intensity of illumination. As for distribution board, checking abnormal heating, looseness and breaking of wire etc. by visual check and check with measuring instrument.
	Power supply system and distribution equipment and buck up generator	Appearance (dirt, damage), looseness, breaking of wire, oil leakage, pipe damage, abnormal noise and vibration etc. by visual check and check with measuring instrument.
	Information collection and provision equipment	Performance, communication and appearance (dirt, damage) of each equipment. Facility/equipment which also defined as ventilation, information collection and provision should be inspected.
	Emergency Facilities	Performance and appearance (dirt, damage) of each equipment. As for signal receiving and control board, abnormal noise and heating etc. are checked by visual check etc.
Cross Passages	Vehicular cross passage doors	Maintenance of the doors (eg: Rolling shutters / Sliding doors or 3M magnet locks etc)
	Pedestrian Cross Passage	CP Doors, Ventilation equipment, Lights etc

Source: NEXCO-WEST and JICA Survey Team

Routine maintenance activities are summarized in the below table and Routine maintenance should be implemented based on the findings of inspection and regular requirements.

**TABLE FOR ROUTINE MAINTENANCE ACTIVITIES**

Component			Routine Maintenance Activity
Civil work Component	Road Surface	Pavement	(1) Crack sealing, (2) Joint repair, (3) repair of heaving, pumping and local settlement (4) Road surface cleaning
	Tunnel Portion	Tunnel Portal	(1) Crack sealing, (2) Cleaning of drainage facilities, (3) Repair of Slope protection work
		Lining	(1) Lining cleaning, (2) Crack sealing, (3) Water leakage prevention, (4) Reinforcement work for the cavity at the back of lining, (5) Joint repair, (6) Delamination repair
		Interior Wall	(1) Wall cleaning
		Drainage	(1) Drainage cleaning

	Fire Boards	(1) Cleaning of fire boards
Electrical/ Mechanical/ Communication Component	Jet Fans	(1) Cleaning, (2) Check the stability, (3) Replacement and overhauling of aged jet fan
	Lighting Facilities	(1) Cleaning, (2) Change a light, (3) Check the stability, (4) Replacement of lighting facility in case of luminance reduction
	All kinds of Signboards	(1) Cleaning, (2) Change a light, (3) Check the stability, (4) Replacement of deteriorated facility
	Emergency Facilities such as Fire Hydrant, Fire Detector, Fire Extinguisher, etc.	(1) Cleaning, (2) Functioning or not, (3) Replacement of facility depending on the deterioration or the damage of the parts
	CCTV, Control system	(1) Cleaning, (2) Check the stability, (3) Functioning or not, (4) Replacement of deteriorated facility
	Other Equipment such as CO Sensor, Visibility Index Sensor, Wind Velocity Sensor	(1) Cleaning, (2) Check the stability, (3) Functioning or not, (4) Replacement of deteriorated facility
	Back Up Generator	(1) Cleaning filters, spark plug, nozzle, (2) Functioning or not, (2) Fuel Amount, (3) Replacement of deteriorated facility

Source: JICA Team

### INDICATIVE TUNNEL O&M ORGANIZATION

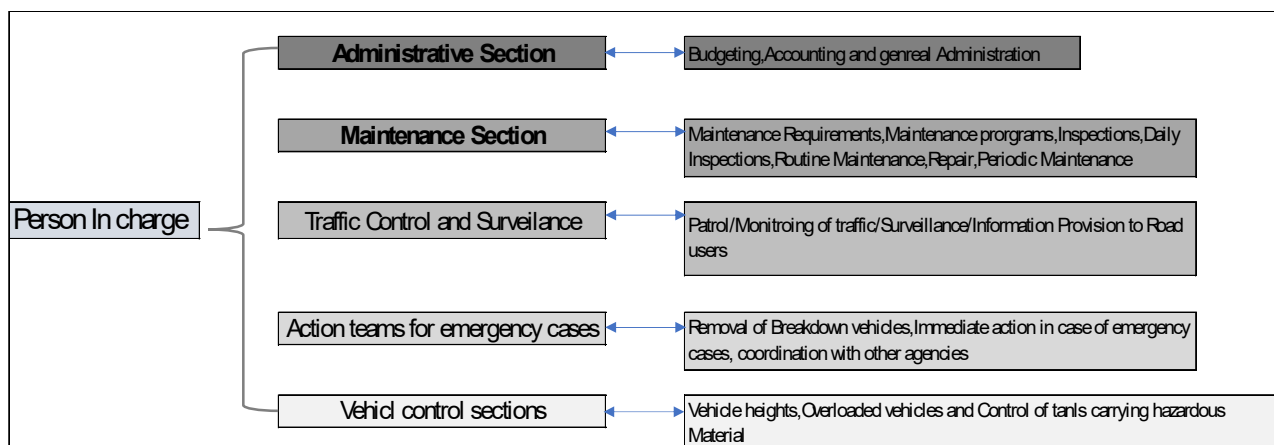

## INDICTIVE ROLES AND FUNCTION OF SECTION/ STAFF

Section	Roles and Function of Section	Roles and Function of Staff
Director	Responsible for overall activities of tunnel management office (2 <sup>nd</sup> rank officer)	
Administration n Section	<ul style="list-style-type: none"> <li>• General Administration</li> <li>• Budgeting</li> <li>• Accounting</li> </ul>	<ul style="list-style-type: none"> <li>• Chief : Responsible for overall activities of this unit</li> <li>• Admin: In charge of general affairs for tunnel management office</li> <li>• Budget: In charge of budget planning and book keeping</li> <li>• Accountant: In charge of accounting</li> </ul>
Maintenance Section	<ul style="list-style-type: none"> <li>• Daily Inspection</li> <li>• Routine Maintenance</li> <li>• Repair</li> <li>• Periodic Maintenance</li> </ul>	<ul style="list-style-type: none"> <li>• Chief : Responsible for overall activities of this unit</li> <li>• Maintenance Planner: In charge of planning of maintenance.</li> <li>• Inspector &amp; Maintenance engineer: In charge of daily inspection and maintenance</li> <li>• Electrical Engineer: In charge of maintenance of Electrical facilities</li> <li>• Mechanical Engineer: In charge of maintenance of Mechanical facilities</li> <li>• Communication Engineer: In charge of maintenance of communication facilities</li> <li>• Civil Engineer: In charge of maintenance of civil structure</li> </ul>
Traffic Control Center/Surveil lance/Information Provision Section	<ul style="list-style-type: none"> <li>• Patrol</li> <li>• Monitoring of traffic</li> <li>• Surveillance</li> <li>• Information provision to road users</li> </ul>	<ul style="list-style-type: none"> <li>• Chief: Responsible for overall activities of this unit</li> <li>• Patrol Team: In charge of daily patrol in tunnel</li> <li>• Traffic Controller: In charge of monitoring of traffic, of surveillance activity and of information provider to road users.</li> </ul>
Action Team for Emergency Case	<ul style="list-style-type: none"> <li>• Removal of breakdown vehicles</li> <li>• Immediate action in case of emergency cases</li> <li>• Coordination with LGUs and Police</li> </ul>	<ul style="list-style-type: none"> <li>• Chief: Responsible for overall activities of this unit</li> <li>• Action team: In charge of Removal of breakdown vehicles, Immediate action in case of emergency cases and coordination with Fire, Traffic and civil police</li> </ul>
Vehicle Control Section	<ul style="list-style-type: none"> <li>• Control of tank lorry carrying hazardous material</li> <li>• Vehicle height &amp;</li> </ul>	<ul style="list-style-type: none"> <li>• Chief: Responsible for overall activities of this unit</li> <li>• Vehicle controller: In charge of vehicle control and of controlling with traffic police</li> </ul>

	overloaded trucks in coordination with Land Transportation office and police	and civil police
--	--	------------------

#### 10.5 Monitoring:

Monitoring is quite important to assure safe operation of a tunnel and to protect road users' lives.

Monitoring Traffic Movement, Traffic Accident, Fire Incidents, etc.

This work must be undertaken for 24-hours a day for 365 days a year. Traffic movements are monitored through CCTV, report from a patrol group and road users. Information shall be compiled at a traffic control center of the Tunnel Management Office, and necessary actions shall be quickly decided and informed to proper agencies and the action team.

Monitoring will be focused on the following:

- Reckless driving
- Overtaking
- Over speeding
- Stopped (stalled)/parked vehicles
- Vehicle breakdown
- Obstacles dropped from vehicles
- Accident
- Fire
- Information collected shall be properly recorded and necessary information shall be provided to road users through Variable Information Signboards and a Loudspeaker.
- Emergency actions shall be made in accordance with the instructions of the head of the monitoring team.

Information collected shall be properly recorded and necessary information shall be provided to road users through Variable Information Signboards and a Loudspeaker.

Emergency actions shall be made in accordance with the instructions of the head of the monitoring team.

Immediate Actions when some incidents are found or reported

The head of the monitoring team shall immediately decide what to do when some incidents are found or reported from road users. He must decide whether a case must be informed to Action Team, Fire Department and/or Police.

Major incidents are as follows;

- Traffic accident
- Fire
- Vehicle Breakdown
- Obstacle dropped from vehicles
- Parked/Stopped (stalled) vehicles

Actions to be taken during emergency cases are illustrated in below Figure

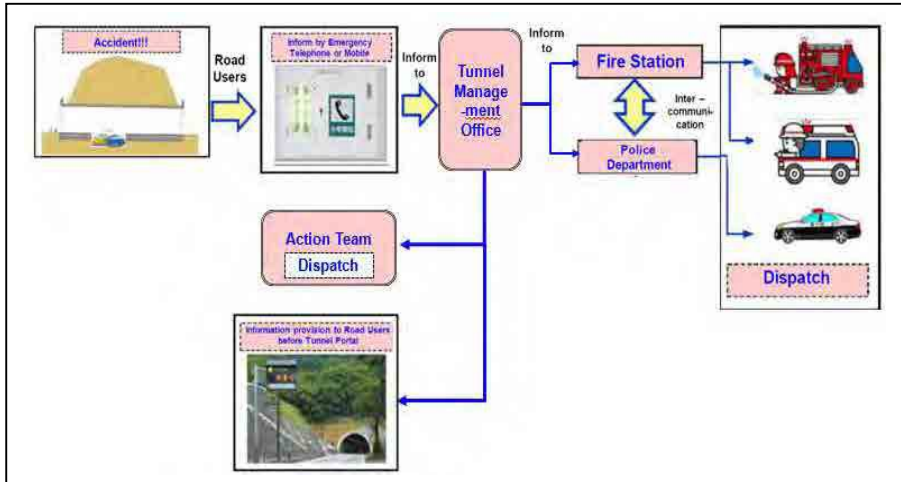
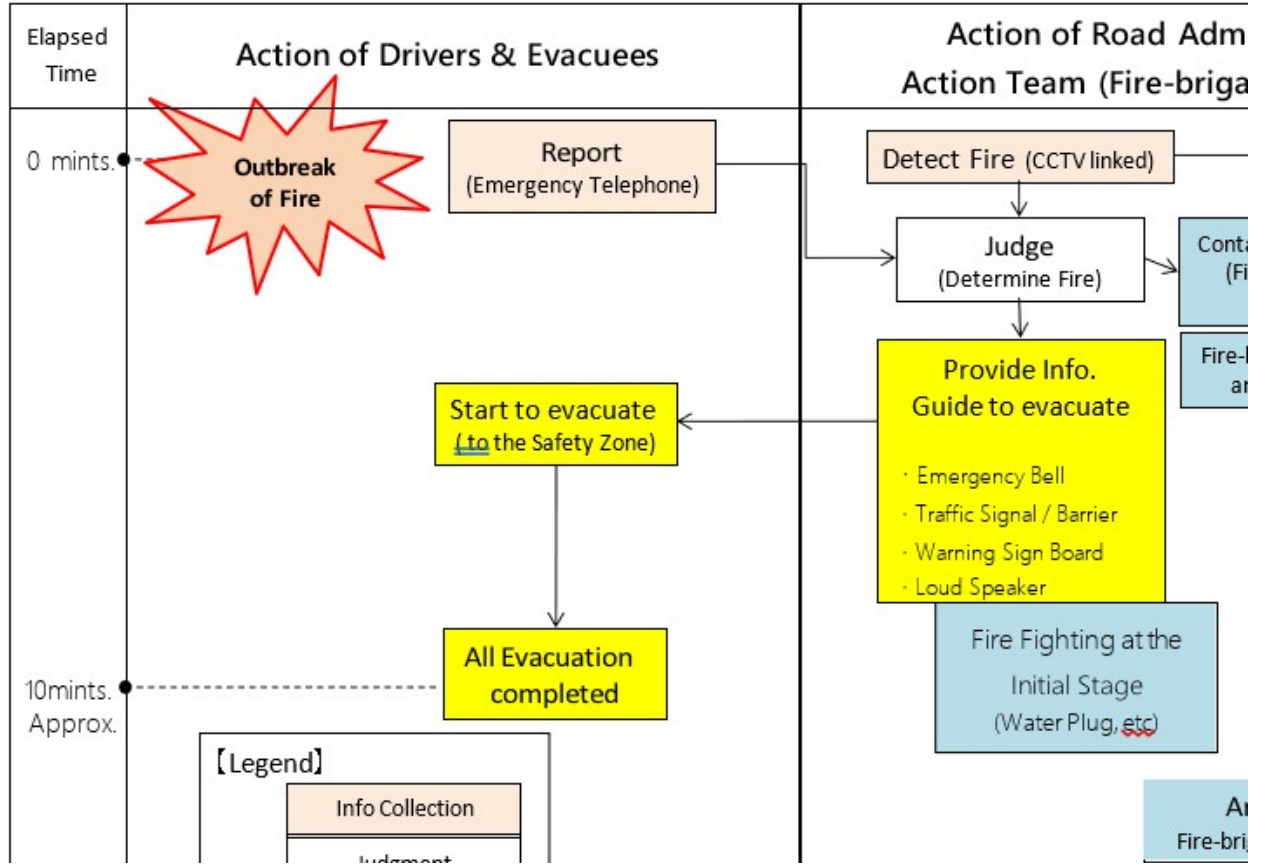
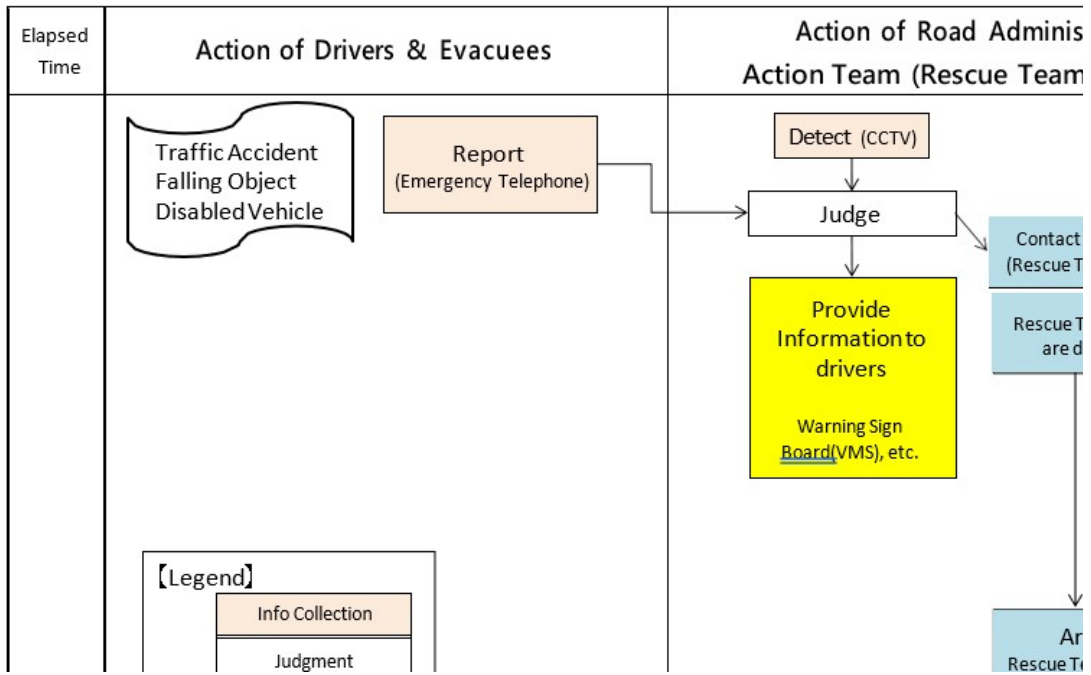

FIGURE: ACTIONS TO BE TAKEN DURING EMERGENCY

Action flows in case of a fire and traffic accident/vehicle breakdown/falling objects are shown in the following Figures



### ACTION FLOW IN CASE OF FIRE



## ACTION FLOW IN CASE OF TRAFFIC ACCIDENT, FALLING OBJECT AND VEHICLE BREAKDOWN

### Vehicle Control

The following vehicles should not be allowed to use a tunnel; thus these vehicles should be controlled before entering a tunnel;

- Two and three wheelers (motorbikes and tricycles [Tempo]) – high probability incidence of causing traffic accident
- Vehicles carrying hazardous materials such as vehicles carrying oil or highly inflammable items– when these get an accident or a fire, it will be dangerous to people and tunnel facilities causing much disaster
- Overloaded trucks – high risk of vehicle breakdown
- Vehicles of which height is exceeding the limit – these will damage other facilities. Height Restricting Devices must be installed at toll gates.
- Others (Mechanically defected vehicles, pedestrians and animals)

It is necessary for the MMRDA to coordinate with Transport Management, Fire Brigade and Traffic police department prior to the tunnel opening

## 10.6 Minimum Equipment Needed for Tunnel O&M

Following are the minimum equipment needed for carrying out the tunnel operations and Management.

Name of Equipment		No. of Unit
Traffic Monitoring and Information Provision	Monitor System	As designed
	Patrol Car	2
	Traffic Control Devices	As designed by the Contractor
Emergency Case	Towing Vehicle	2
	Air Jack	2
	Truck for Transport of Air Jack	2
	Fire Truck	2
	Ambulance Car	2
	Height Restricting Device (Gate Type)	2
Name of Equipment		No. of Unit
Inspection & Maintenance Work	Road Sweeper	1
	Wall Cleaning Vehicle	1
	Water Supply Equipment for Cleaning	1
	High Platform Mounted Vehicle	1
	Station Wagon	1
	Inspection Machinery, Measuring Instrument and Tools	1 set

## 10.7 Fund Source of Tunnel O&M Cost

Fund Source

There are two (2) possible fund sources as follows;

**Case-1: A toll is collected from tunnel users**

**Case-2: Self-funding**

## 10.8 CAPACITY DEVELOPMENT FOR TUNNEL O&M

### Necessity of Capacity Development

capacity for tunnel O&M must be developed prior to opening of the tunnel. Capacity development should cover various aspects in relation to tunnel O&M as follows

#### ***Violation of traffic rules (coordination with traffic police)***

Confirm rules and regulations included in the “Road Safety Rules”, an example follows:

- Legal speed limit
- Height Limit
- Prohibition of motorbikes passing in tunnels
- Prohibition of overtaking in tunnels
- Obligation of vehicle maintenance
- Prevention of load shifting and falling objects
- Obligation of relief activities in accidents

Basically, The Management office, against violating vehicles of these traffic rules, will request related agency (traffic police) to control them (arrest, penalty, etc.), and as a part which keeps constant monitoring, will engage to ‘call attention, give instruction and remove’ to them for the delegated matters, and for the undelegated matters, will request the related agency (traffic police) to dispatch.

#### ***Traffic accident (coordination with traffic police)***

Request the related agency (traffic police) to investigate the cause of the accident and to take legal actions. At the same time, The Management office will conduct lane regulation, close the road and remove (tow away) damaged vehicles immediately for prevention of the secondary accidents and restoration of the normal traffic. The Management office will also conduct necessary emergency repairs to restore the traffic.

#### ***Fire incident (coordination with Fire Department)***

Confirm which powers are necessary for fire-fighting activities at a fire incident, an example follows:

Right-of-way

Order to remove vehicles

Rights regarding damage, etc

And coordinate with the related agency (fire department) to determine which tasks could be delegated to the Management office.

The Management office carries out fire-fighting activities within the delegated powers. If The Management office cannot extinguish the fire within its delegated powers, it will request the fire department to dispatch.

If fire-fighting activities within the delegated powers are difficult and the arrival of the fire department may take time, consider requesting for establishing a fire department in proximity (or within the management office).

#### ***Vehicle control (coordination Traffic Department and Police Department)***

Confirm rules and regulations included in the “Rules to Protect Road Structures”, an example follows:

- Height limitations of a vehicle
- Weight limitations of a vehicle
- Width limitations of a vehicle
- Prohibition of passage of the vehicles carrying hazardous materials

The Management office will give warnings to and remove vehicles which violate these rules within its delegated powers. It will take joint actions in coordination with the related agency (traffic police) for issues outside its delegated powers.

#### ***Lane regulation and Road closing (coordination with traffic police)***

Confirm which powers is necessary for lane regulation and road closing and will coordinate with the related agency (traffic police) to identify which actions are necessary for the management office to conduct lane regulation and road closing.

#### **Inspection and Maintenance Work**

The performance of inspection and maintenance work often depends on the five physical senses of the worker. Therefore, it is required for the worker to have advanced knowledge and experience.

For this reason, the following topics should be covered in the field of inspection and maintenance work.

- Responsibilities of the Maintenance Section and coordination with other sections.
- Inspection frequency
- What to inspect and how to record findings of inspection
- Preparation of Inspection and Maintenance Manual
- Traffic Control/Management during maintenance work

The details are as follows:

- An “Inspection Manual” will be developed which covers the following objects:
- Contents of an inspection
- Frequency of an inspection
- Criteria of an inspection
- How to record the results
- How to report the results

- The manual will be distributed to workers and a training course will be held to familiarize them with the manual.
- A training course will be held to familiarize workers with usage of vehicles, measuring instruments, tools and equipment for an inspection based on their instruction manuals and through usage demonstrations of the actual machine.
- Inspection and maintenance work may be dangerous because of work on the road currently in use, in high places, related to electricity and oil, etc. For this reason, safety training will be conducted, a check sheet will be developed, and a safety manager will be appointed. A safety manager in this context is a person who is responsible for safe work by supervising workers.
- Prior to opening, field training and an initial inspection will be held at the actual objects for inspection in order to obtain actual experience and to understand and record the initial condition of the objects.
- Some work requires joint work with other sections, such as lane regulation (coordination with Patrol Team), and confirmation of signal reception/concerted work (coordination with traffic control Centre)
- Therefore, necessary tasks for smooth work should be identified and organized.
- Documents useful for understanding details of the object should be compiled as a reference so that they could be referred to as necessary during the maintenance work.

#### 10.9 Traffic Monitoring and Information Provision

Traffic Control Center gathers various information continuously and makes judgment and takes actions (i.e. provide information, operate, instruct and request) accordingly.

The following topics should be covered in the field of traffic monitoring and information provision.

- Responsibilities of Patrol Teams and Traffic Control Centre
- What kinds of equipment installed and functions of each equipment
- What to be monitored by Traffic Control Centre and Patrol Teams
- What information to be collected and what information to be provided to tunnel users
- What actions to be made when some irregularities are found
- What to be coordinated with other sections/teams and traffic police/fire department of LGUs/hospitals
- What communication systems to be established with other sections, traffic police, concerned LGUs and hospitals

The summary of Traffic control centre is shown below.

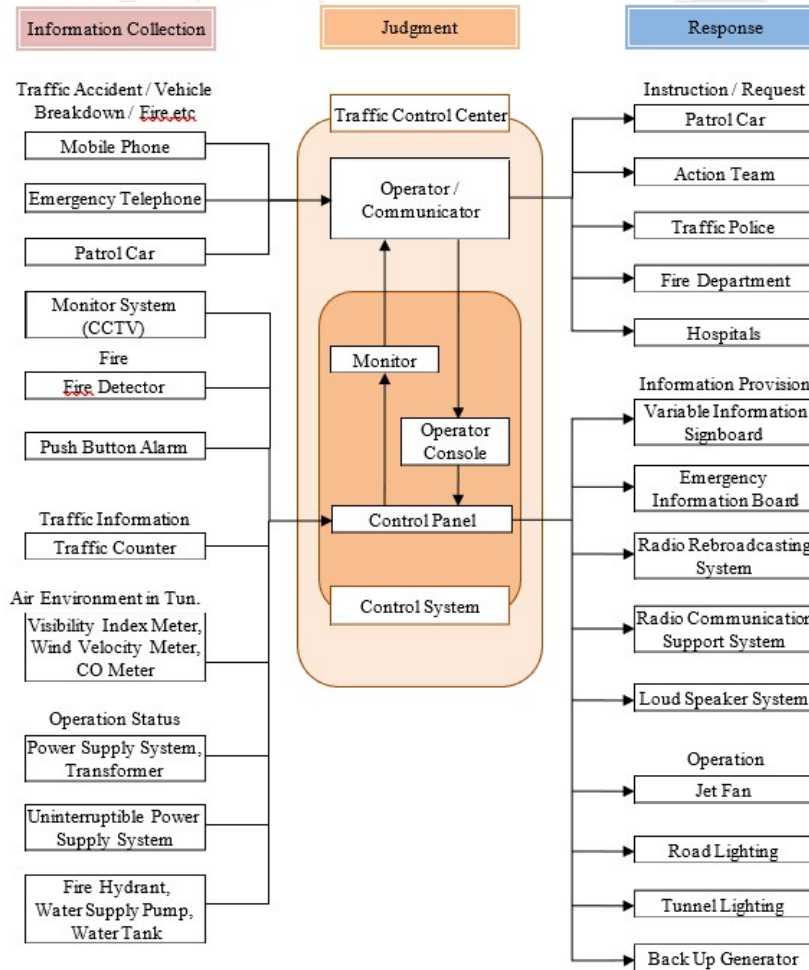

### Safety Requirements

Tunnel Maintenance activities both planned and unplanned shall be carried out by proper traffic management.

To plan maintenance and operation that effect vehicle traffic, as these may be cause of accidents involving user of the tunnel or the workers operating the maintenance equipment, certain precautions as enumerated below shall be taken for safety of traffic as well as maintenance staff.

- Maintenance staff working in tunnel shall be protected from errant vehicles entering the tunnel. For that purpose, warning signs shall be posted at appropriate location and one driving lane shall be closed completely by barriers and providing proper warning signages /Signals well in advance for safety of coming traffic.

- The closer of lane shall be indicated before the road enters tunnel. Variable messages, traffic signs, barriers shall be used for the purpose.

10.10 Information leaflets: Case Study (IRC: SP :91 -2019)

With regard to the behaviour in tunnels in case of an emergency,

Attached below is the leaflet from IRC: SP :91 -2019 which can be provided as information at both Toll plaza and approaches to the tunnel.

 <b>What to do when you are entering a tunnel.</b>	<b>What to do in the event of breakdown or accident.</b>
 Switch on your <b>headlights</b> . Take off your <b>sunglasses</b> .  <b>Obey Traffic lights and signs.</b>  <b>Keep a safe distance</b> from the vehicle in front.  <b>Do not overtake</b> if there is only one lane in each direction.  <b>Do not turn or reverse. Do not stop</b> , except in an emergency.	Switch on your <b>warning lights</b> Try to <b>move your vehicle</b> to a <b>emergency lane</b> or lay-by or a the hard shoulder. <b>Switch off the Engine</b> <b>Leave your Vehicle</b> If necessary and possible, give t <b>injured people</b> . <b>Call for help</b> form an emerger
 <b>What to do in Traffic Congestion.</b>	<b>What to do if your or anothe is on fire.</b>
 Switch on your <b>warning lights</b> .  <b>Keep your distance</b> , even if you are moving slowly or have stopped.  <b>Switch off your engine</b> , if the traffic has come to a halt.  <b>Follow the instructions</b> given by tunnel officials or <b>obey variable</b>	If your vehicle is on fire, if poss <b>out of the tunnel</b> . If that is not possible, <b>pull ove</b> side, <b>switch off the engine</b> ar <b>the vehicle</b> immediately. <b>Call for help</b> from an emerger If you can, <b>put out the fire</b> usi <b>extinguisher</b> available in the t

Source: IRC : SP :91 -20

## Codes and References

In addition to the codes that are referred in this document, the following are also being considered.

The relevant and applicable design codes are the Indian Standards (BIS), the British Standards (BS), the American Standard (ASTM, AASHTO); NFPA, PIARC (World Road Association- Paris ) the Codes of Practice Majority of these codes are related to construction. Generally Indian codes and standards are to be preferred except in those instances where no comprehensive documents exist. In such cases equivalent international codes and standards will be used.

The codes and references used for design of structures are summarized below:

### Bureau of Indian Standards (IS)

- IS 456: 2000 – Plain & Reinforced Concrete
- IS 800: 1984 – General Construction in Steel
- IS 875: 1987 – Design Loads (other than earthquake) for Building and Structures, Part 1: Dead Load & Part 2: Imposed Loads
- IS 1893: 1984 – Criteria of Earthquake Resistant Design of Structures
- IS 1904:1986 – Design and Construction of Foundations in Soils – General Requirements
- IS 2911:1979 – Design and Construction of Pile Foundations (Parts 1 to 4)
- IS 2950:1981 – Design and Construction of Raft Foundations
- IS 3370:1965 – Concrete Structures for the Storage of Liquids (Parts 1 to 4)
- IS1080:1985 - Code of Practice for Design and Construction of Shallow Foundation in Soil
- IS2062:1992 - Steel for General Structural Purposes-Specification
- IS2720:1962 - Methods of Tests for Soils
- IS2751:1979 - Code of Practice for Welding of Mild Steel Plain and Deformed Bars used for Reinforced Concrete Construction
- IS5525:1969 - Recommendations for Detailing of Reinforcement in Reinforced Concrete Works
- IS6403:1981 - Code of Practice for Determination of Bearing Capacity of Shallow Foundations
- IS8009 - Calculation of Settlement of Foundations
- IS: 4081 Safety code for Blasting and related drilling operations
- IS: 5878 Code of practice for construction of tunnels

### British Standards (BS)

- BS:6164 -Safety in tunnelling
- BD 78/99: Design of Road tunnels
- BS:5400 - Steel, Concrete and Composite Bridges
- BS:5950-1 - Structural Use of Steelwork in Building

BS/EN 13201 Road Lighting

BS:8110 - Structural Use of Concrete

BS:5266 -Emergency Lighting

### **American Association of State Highway and Transportation Officials**

AASHTO LRFD Load Combinations

AASHTO M 31-82 Deformed and plain billet – steel for concrete reinforcement

AASHTO M42 – 81 Rail – steel deformed and plain bars for concrete reinforcement

AASHTO M54-81 Fabricated steel bar or rod mats for concrete reinforcement

AASHTO T 22-82 Compressive strength of cylindrical concrete specimens

### **MEP Systems and safety**

NFPA.

ASHRAE

PIARC

IRC: SP:91(2019)

MORTH

Road Tunnels (Norwegian Public Roads Administration)

BS 5499 Fire Exit signs

CIE 88 Guide for the lighting of road tunnels and Underpasses

### **International Electrotechnical Commission**

IEC 60598 Luminaries – General requirements and testing

IEC 60669 Switches for household and similar fixed -electrical installations

IEC 60921 Ballasts for tubular fluorescent lamps -Performance requirements

IEC 60085 Electrical insulation – Thermal evolution and designation

### **International Tunnel Association**

ITA-AITES Guidelines for the Design of Tunnels

ITA-AITES Seismic design and analysis of underground structures

ITA WG 6 Maintenance and Repair- Structural Fire Protection For ROAD Tunnels

ITA Working Group 2 - Guidelines for the design of segmental linings

ITA Working Group - TBM Excavation of Long and deep tunnels under difficult rock conditions

ITA Working Group - Adits for Long and Deep Tunnels

### **Others**

Austrian Society for Rock Mechanics: Geotechnical Underground Structure Design

- 
- Austrian Concrete Society: Guideline “Shotcrete”, Vienna, 2001
- ON B2203-1:2001 Underground Works – Work Contract, Part 1: Cyclic Driving (conventional tunnelling)
- ON B2203-2:2001 Underground Works – Work Contract, Part 1: Continuous Driving (TBM tunnelling)
- Specification for Tunneling: The British Tunnelling Society and Institution of Civil Engineers, Thomas Telford Publishing, 2000
- A Contribution to the Analysis of Stress in a Circular Tunnel: H D Morgan, Geotechnique, 1971 March pp 37-46
- The Circular Tunnel in Elastic Ground: A. M. Muir-Wood, Geotechnique 1975
- Visco-elastic Tunnel Analysis: J. D. Curtis, Discussion, Geotechnique 1976
- Seismic design and analysis of underground structures, Youssef M.A. Hashash, Jeffrey J. Hook, Birger Schmidt, John I-Chiang Yao
- Investigation and analysis on the vehicle cross passages of Highway Tunnels - IOP Conference series - Bin Li ,Wei Li ,Lianghong Lu and Shuai Liu

---

## Chapter 11 -Annexures (Attached separately)

- Annexure 1 - MSRDC approval note -Option 2 of alignment
- Annexure 2- Letter from Forest department for TBM Tunneling method
- Annexure 3- Sample calculation for Precast Tunnel lining
- Annexure 4 -Guideline for design of steel Fiber reinforced precast segments
- Annexure 5- Hong Kong TMCLK\_CA water fix
- Annexure 6 – TMCKL Project information sheet